

Teil Z.Nr. 37014320 wird einpresst

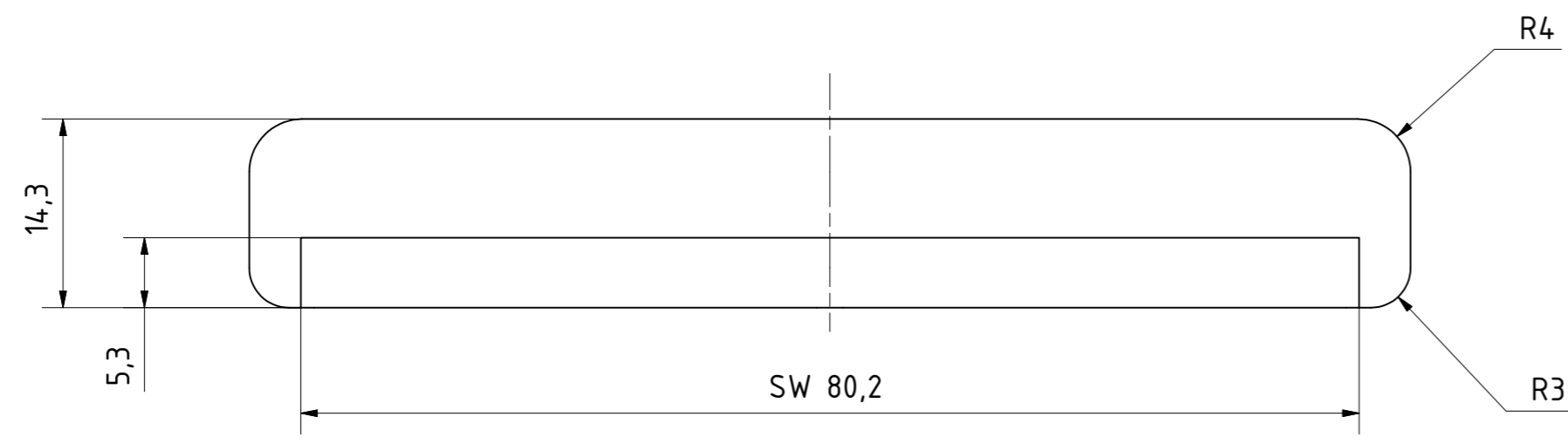
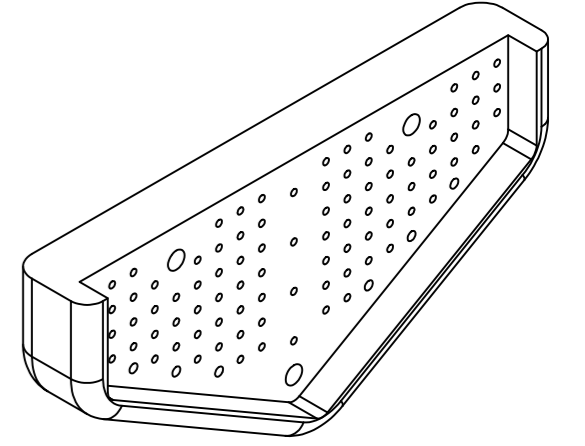

		<b>ERHALTEN</b> Von Vogt, 11:38, 20.11.2008	
Hauptprojektion 		MAX-PLANCK-INSTITUT FUER PHYSIK MUENCHEN (WERNER-HEISENBERG-INSTITUT)	
Tag 12.12.2007		Name fsi	
gezeichnet geprueft geplottet		Projekt <b>GERDA</b> TEST string slide with contacts	
Maßstab 2:1 (1:1)		Zeichnungsnummer / EDV Nr.: <b>37014319.idw</b>	
		Gewicht.....: ..... kg Dimensionen : mm Maße ohne Toleranzangabe nach DIN ISO 2768 mK	
		Werkstoff <b>PE-UHMW HD-1000</b>	
		Software.....: Inventor 8 Blatt.....: 1 Gesamtzahl: 1	
		V09.f	