

C (2:1)

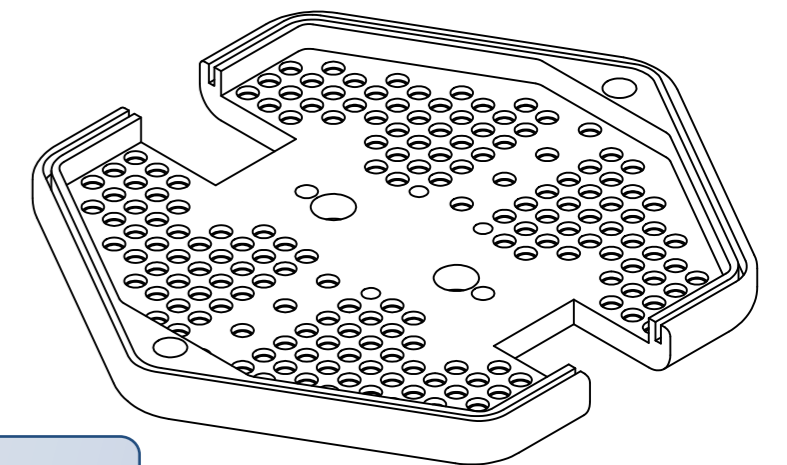
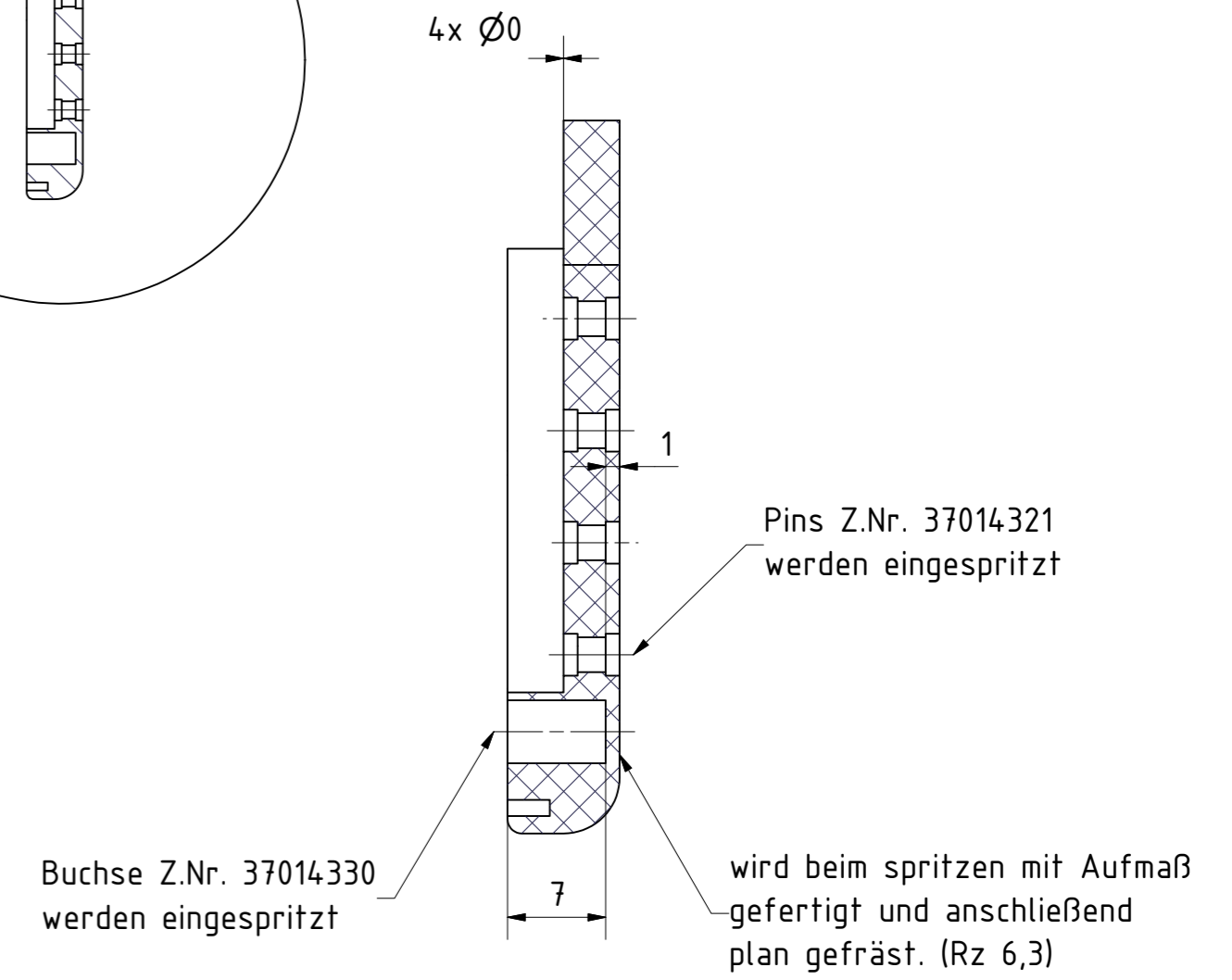

ERHALTEN
Von Vogt, 11:37, 20.11.2008

		Anschließend werden alle Metallteile vergoldet.	
Hauptprojektion		MAX-PLANCK-INSTITUT FUER PHYSIK MUENCHEN (WERNER-HEISENBERG-INSTITUT)	Gewicht.....: kg Dimensionen : mm Maße ohne Toleranzangabe nach DIN ISO 2768 mK
gezeichnet	Tag 10.12.2007	Name tsi	Werkstoff iglidur J natur
gepruefft			
geplottet			
Maßstab 1:1 (1:2)	Projekt GERDA TEST string slide with contacts		Zeichnungsnummer / EDV Nr.: 37014310.idw
	Teil: Pinplatte		Software.....: Inventor 8 Blatt.....: 1 Gesamtzahl: 1