

Lecture:

Standard Model of Particle Physics

Heidelberg SS 2013

Weak Interactions I

Spinors and Helicity States

momentum vector in +z direction

$$u_R = |\vec{p}, \lambda = +1/2\rangle \quad (u_1)$$

$$u_L = |\vec{p}, \lambda = -1/2\rangle \quad (u_2)$$

$$v_L = |\vec{p}, \lambda = -1/2\rangle \quad (v_1)$$

$$v_R = |\vec{p}, \lambda = +1/2\rangle \quad (v_2)$$

or more general:

fermions:

$$u_R = \sqrt{E+m} \begin{pmatrix} 1 \\ 0 \\ \frac{|\vec{p}|}{E+m} \\ 0 \end{pmatrix}$$

$$u_L = \sqrt{E+m} \begin{pmatrix} 0 \\ 1 \\ 0 \\ \frac{-|\vec{p}|}{E+m} \end{pmatrix}$$

limit $p \rightarrow \infty$

anti-fermions:

$$v_L = \sqrt{E+m} \begin{pmatrix} \frac{|\vec{p}|}{E+m} \\ 0 \\ 1 \\ 0 \end{pmatrix}$$

$$v_R = \sqrt{E+m} \begin{pmatrix} 0 \\ \frac{-|\vec{p}|}{E+m} \\ 0 \\ 1 \end{pmatrix}$$

$$u_R \rightarrow v_L$$

$$u_L \rightarrow v_R$$

Chirality Operator

limit: $m \rightarrow 0, p \rightarrow \infty$

$$u_R \sim v_L \sim \begin{pmatrix} 1 \\ 0 \\ 1 \\ 0 \end{pmatrix} \quad u_L \sim v_R \sim \begin{pmatrix} 0 \\ 1 \\ 0 \\ -1 \end{pmatrix}$$

operator: $\gamma^5 = i \gamma^0 \gamma^1 \gamma^2 \gamma^3 = \begin{pmatrix} 0 & 0 & 1 & 0 \\ 0 & 0 & 0 & 1 \\ 1 & 0 & 0 & 0 \\ 0 & 1 & 0 & 0 \end{pmatrix} = \begin{pmatrix} 0 & \underline{1} \\ \underline{1} & 0 \end{pmatrix}$

right chirality

$$\gamma_5 u_R = u_R$$

$$\gamma_5 v_L = v_L$$

left chirality

$$\gamma_5 u_L = -u_L$$

$$\gamma_5 v_R = -v_R$$

eigenvalues ± 1

left-handed (chiral) particles: -1

right-handed (chiral) particles: +1

note: a right-handed chiral anti-particle has a left-handed helicity

Projection Operator

Definition: $\Pi^{\pm} = \frac{1 \pm \gamma_5}{2}$

in the limit of $|E| \rightarrow \text{infinity}$

fermions

$$\begin{aligned} \Pi^+ u_R &= u_R & \Pi^+ u_L &= 0 \\ \Pi^- u_L &= u_L & \Pi^- u_R &= 0 \end{aligned}$$

anti-fermions

$$\begin{aligned} \Pi^+ \nu_L &= \nu_L & \Pi^+ \nu_R &= 0 \\ \Pi^- \nu_R &= \nu_R & \Pi^- \nu_L &= 0 \end{aligned}$$

can reformulate Dirac Equation:

$$i \gamma^\mu \partial_\mu u_R = m u_L \qquad i \gamma^\mu \partial_\mu u_L = m u_R$$

note: massive fermions must have left-handed and right handed components

Recap

General Four Fermion Lagrangian

$$L = \frac{G}{\sqrt{2}} (\bar{f} \Gamma f') (\bar{f}'' \tilde{\Gamma} f''')$$

Vector Current:

$$j_V^\mu = \bar{\psi} \gamma^\mu \psi$$

Axial-vector Current:

$$j_A^\mu = \bar{\psi} \gamma^\mu \gamma^5 \psi$$

scalar coupling:

$$\lambda = \bar{\psi} \psi$$

pseudoscalar coupling:

$$\lambda = \bar{\psi} \gamma^5 \psi$$

Tensor Coupling

$$\sigma_A^{\mu\nu} = \bar{\psi} (\gamma^\mu \gamma^\nu - \gamma^\nu \gamma^\mu) \psi$$

Vector, Axial and Scalar Currents

Vector Current:

$$j_V^\mu = \bar{u} \gamma^\mu u$$

$$\bar{u} \gamma^\mu u = \bar{u}_L \gamma^\mu u_L + \bar{u}_R \gamma^\mu u_R$$

in QED: $\partial_\mu j_V^\mu = 0$

(no helicity flip)

Axial-vector Current:

$$j_A^\mu = \bar{u} \gamma^\mu \gamma^5 u$$

$$\bar{u} \gamma^\mu \gamma^5 u = \bar{u}_L \gamma^\mu \gamma^5 u_L + \bar{u}_R \gamma^\mu \gamma^5 u_R$$

note: $\gamma^\mu \gamma^5 = -\gamma^5 \gamma^\mu$

(no helicity flip)

Scalar Coupling

$$\bar{u} u = \bar{u}_R u_L + \bar{u}_L u_R$$

(helicity flip!)

Relations:

$$j_L^\mu = 1/2 (j_V^\mu - j_A^\mu)$$

$$j_R^\mu = 1/2 (j_V^\mu + j_A^\mu)$$

Helicity Example

Particle at almost rest ($0 < p \rightarrow 0$) with spin orientation in +z direction:

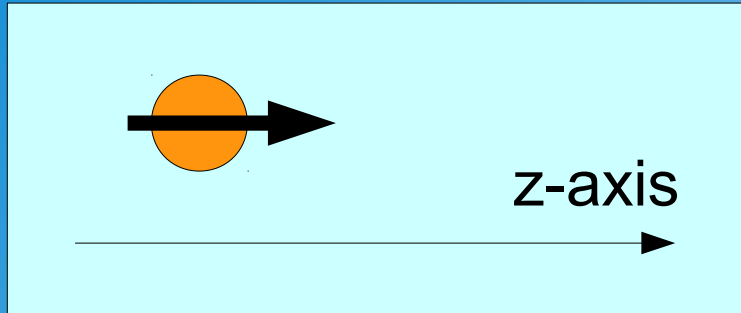

polarisation: $\lambda = \vec{j} \cdot \vec{z} = \frac{N_{+1/2} - N_{-1/2}}{N_{+1/2} + N_{-1/2}} = 1$

helicity: $H = \frac{\vec{j} \cdot \vec{p}}{|\vec{p}|} = 1$ (classical)

Helicity Example

Particle at almost rest ($0 < p \rightarrow 0$) with spin orientation in +z direction:

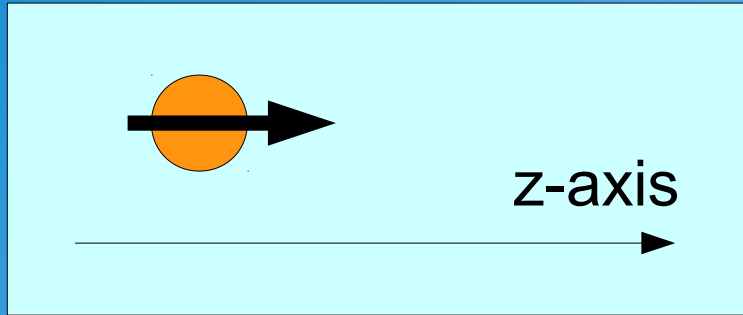

polarisation: $\lambda = \vec{j} \cdot \vec{z} = \frac{N_{+1/2} - N_{-1/2}}{N_{+1/2} + N_{-1/2}} = 1$

helicity: $H = \frac{\vec{j} \cdot \vec{p}}{|\vec{p}|} = 1$ (classical)

- In a classical approach states with defined helicities ($H = \pm 1$) can be prepared.
- In Quantum mechanics the spin and momentum are to be replaced by operators.
- For massive particles the helicity is not Lorentz invariant.
- This is easily seen in the above example:

For $p \rightarrow p' = -p$ the helicity makes a flip: $H \rightarrow H' = -1$

Helicity Example

Particle almost at rest ($0 < p \rightarrow 0$) with spin orientation in +z direction:

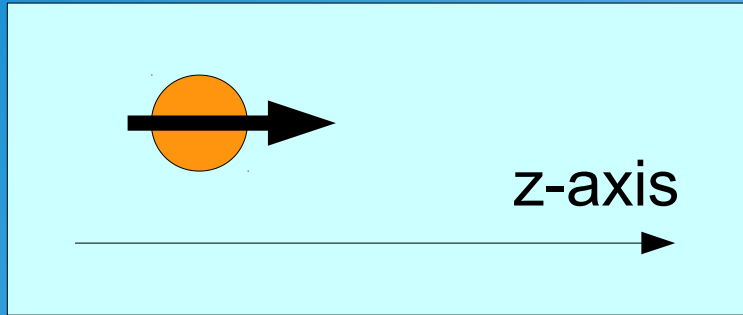

polarisation: $\lambda = \vec{j} \cdot \vec{z} = \frac{N_{+1/2} - N_{-1/2}}{N_{+1/2} + N_{-1/2}} = 1$

helicity: $H = \frac{\vec{j} \cdot \vec{p}}{|\vec{p}|} = 1$ (classical)

In a Lorentz invariant theory, particle interactions can not be described by non-Lorentz invariant quantities!

→ The solution to this problem is provided by the Dirac equations

Dirac spinors: $u = u_L + u_R$

only the chiral states
in the limit $p \rightarrow \infty$
are Lorentz invariant

$$u_R = \begin{pmatrix} 1 \\ 0 \\ 1 \\ 0 \end{pmatrix} \quad u_L = \begin{pmatrix} 0 \\ 1 \\ 0 \\ -1 \end{pmatrix}$$

Helicity Example

Particle almost at rest ($0 < p \rightarrow 0$) with spin orientation in +z direction:

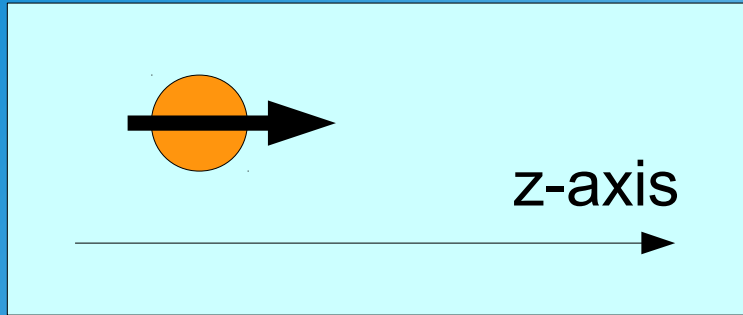

polarisation: $\lambda = \vec{j} \cdot \vec{z} = \frac{N_{+1/2} - N_{-1/2}}{N_{+1/2} + N_{-1/2}} = 1$

helicity: $H = \frac{\vec{j} \cdot \vec{p}}{|\vec{p}|} = 1$ (classical)

$$u = u_L + u_R = \sqrt{E+m} \begin{pmatrix} 0 \\ 1 \\ 0 \\ \frac{-|\vec{p}|}{E+m} \end{pmatrix} + \sqrt{E+m} \begin{pmatrix} 1 \\ 0 \\ \frac{|\vec{p}|}{E+m} \\ 0 \end{pmatrix} = \sqrt{2m} \begin{pmatrix} 0 \\ 1 \\ 0 \\ 0 \end{pmatrix} + \sqrt{2m} \begin{pmatrix} 1 \\ 0 \\ 0 \\ 0 \end{pmatrix}$$

Helicity Example

Particle at almost rest ($0 < p \rightarrow 0$) with spin orientation in +z direction:

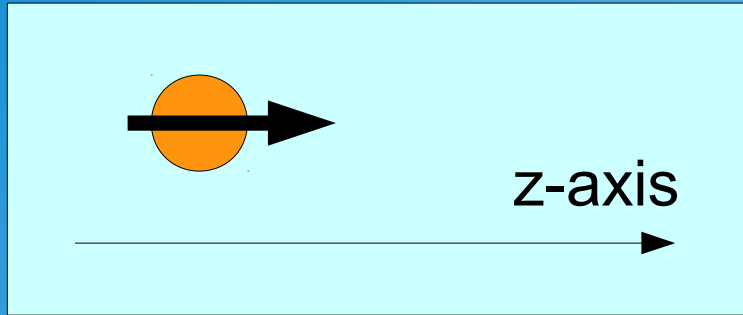

polarisation: $\lambda = \vec{j} \cdot \vec{z} = \frac{N_{+1/2} - N_{-1/2}}{N_{+1/2} + N_{-1/2}} = 1$

helicity: $H = \frac{\vec{j} \cdot \vec{p}}{|\vec{p}|} = 1$ (classical)

$$u = u_L + u_R = \sqrt{E+m} \begin{pmatrix} 0 \\ 1 \\ \frac{-|\vec{p}|}{E+m} \\ 0 \end{pmatrix} + \sqrt{E+m} \begin{pmatrix} 1 \\ 0 \\ \frac{|\vec{p}|}{E+m} \\ 0 \end{pmatrix} = \sqrt{2m} \begin{pmatrix} 0 \\ 1 \\ 0 \\ 0 \end{pmatrix} + \sqrt{2m} \begin{pmatrix} 1 \\ 0 \\ 0 \\ 0 \end{pmatrix}$$

Projection of right helicity state

$$\Pi^+ u = \frac{1+\gamma_5}{2} u = \frac{\sqrt{2m}}{2} \begin{pmatrix} 0 \\ 1 \\ 0 \\ 1 \end{pmatrix} + \frac{\sqrt{2m}}{2} \begin{pmatrix} 1 \\ 0 \\ 1 \\ 0 \end{pmatrix} \quad \Pi^- u = \frac{1-\gamma_5}{2} u = \frac{\sqrt{2m}}{2} \begin{pmatrix} 0 \\ -1 \\ 0 \\ 1 \end{pmatrix} + \frac{\sqrt{2m}}{2} \begin{pmatrix} -1 \\ 0 \\ 1 \\ 0 \end{pmatrix}$$

Helicity Example

Particle at almost rest ($0 < p \rightarrow 0$) with spin orientation in +z direction:

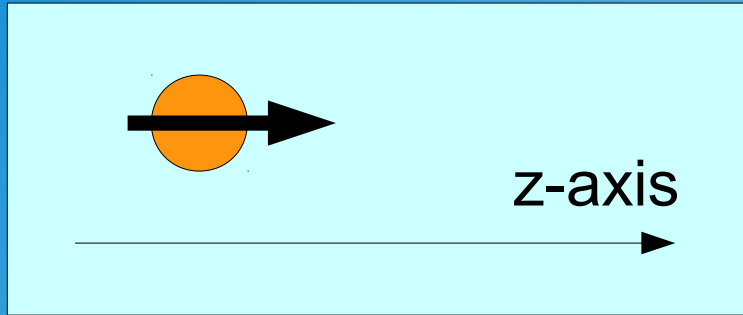

polarisation: $\lambda = \vec{j} \cdot \vec{z} = \frac{N_{+1/2} - N_{-1/2}}{N_{+1/2} + N_{-1/2}} = 1$

helicity: $H = \frac{\vec{j} \cdot \vec{p}}{|\vec{p}|} = 1$ (classical)

$$u = u_L + u_R = \sqrt{E+m} \begin{pmatrix} 0 \\ 1 \\ \frac{-|\vec{p}|}{E+m} \\ 0 \end{pmatrix} + \sqrt{E+m} \begin{pmatrix} 1 \\ 0 \\ \frac{|\vec{p}|}{E+m} \\ 0 \end{pmatrix} = \sqrt{2m} \begin{pmatrix} 0 \\ 1 \\ 0 \\ 0 \end{pmatrix} + \sqrt{2m} \begin{pmatrix} 1 \\ 0 \\ 0 \\ 0 \end{pmatrix}$$

Projection of right helicity state

$$\Pi^+ u = \frac{1+\gamma_5}{2} u = \frac{\sqrt{2m}}{2} \begin{pmatrix} 0 \\ 1 \\ 0 \\ 1 \end{pmatrix} + \frac{\sqrt{2m}}{2} \begin{pmatrix} 1 \\ 0 \\ 1 \\ 0 \end{pmatrix}$$

⇓ ⇑

50% right chiral states

$$\Pi^- u = \frac{1-\gamma_5}{2} u = \frac{\sqrt{2m}}{2} \begin{pmatrix} 0 \\ -1 \\ 0 \\ 1 \end{pmatrix} + \frac{\sqrt{2m}}{2} \begin{pmatrix} -1 \\ 0 \\ 1 \\ 0 \end{pmatrix}$$

⇑ ⇓

50% left chiral state

Test of Lorentz Structure?

Fermi transition LH anti-neutrino helicity

Gamov Teller transition

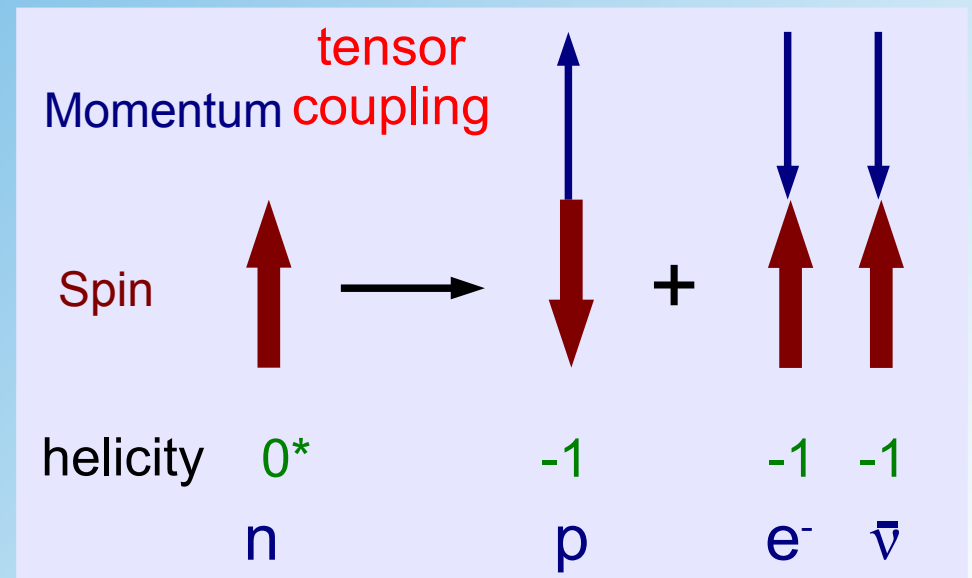
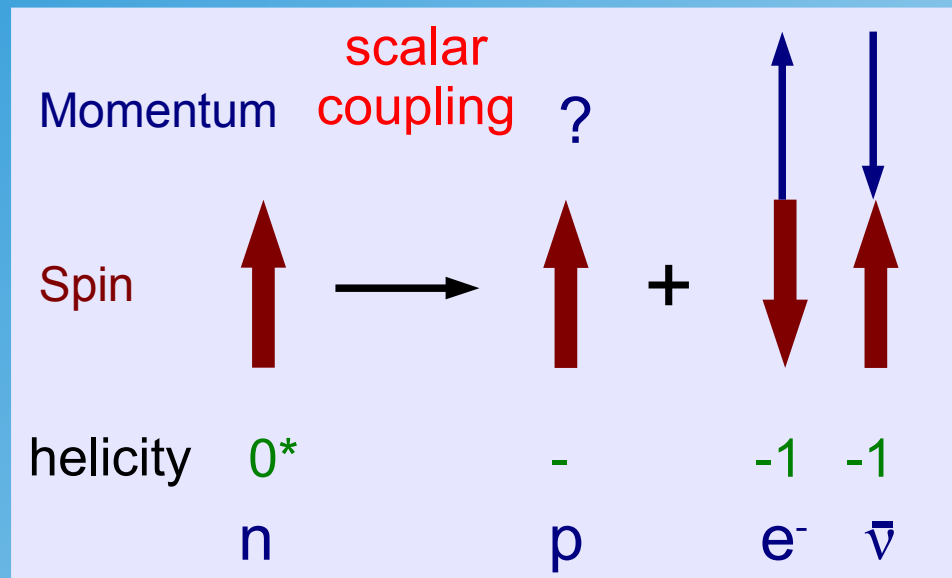
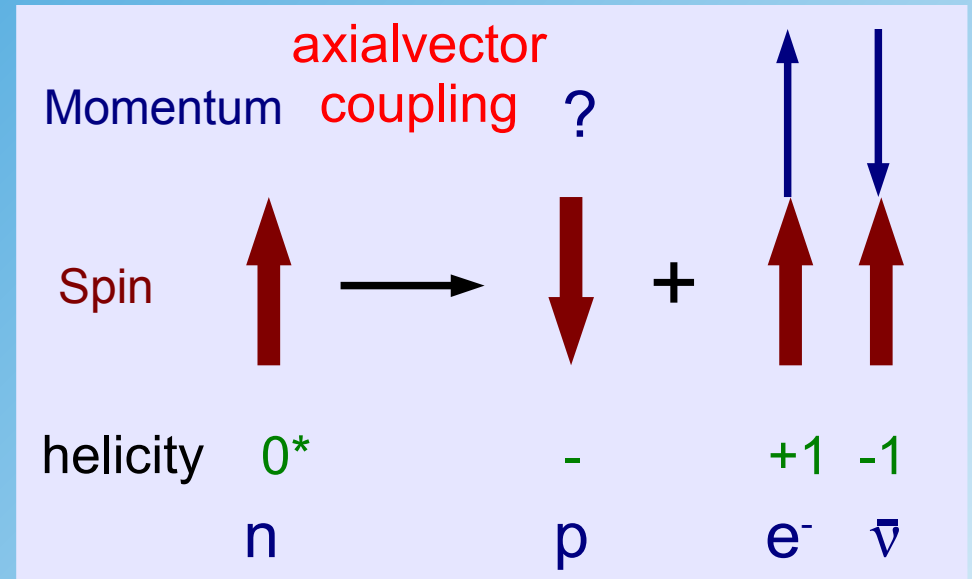
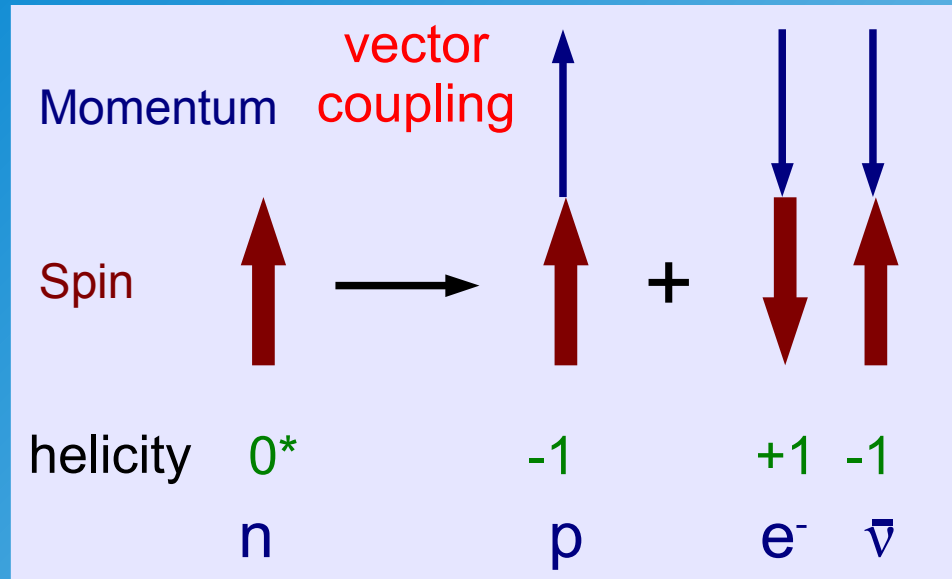

Test of Lorentz Structure?

Fermi transition RH anti-neutrino helicity Gamov Teller transition

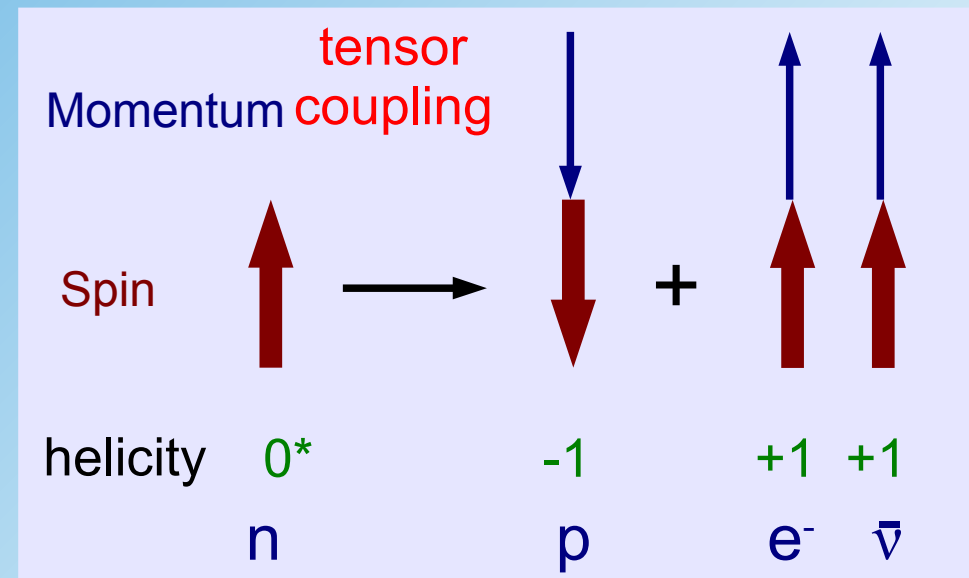
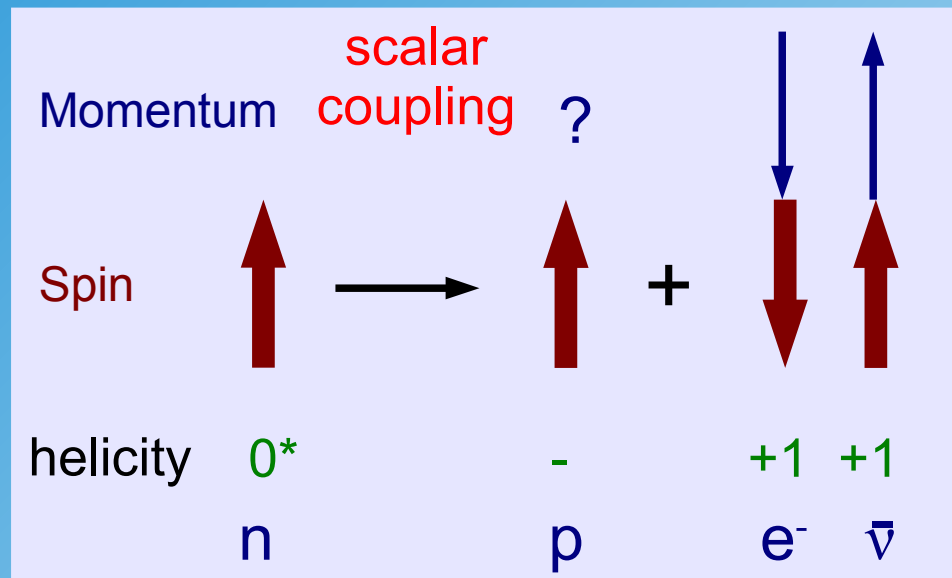
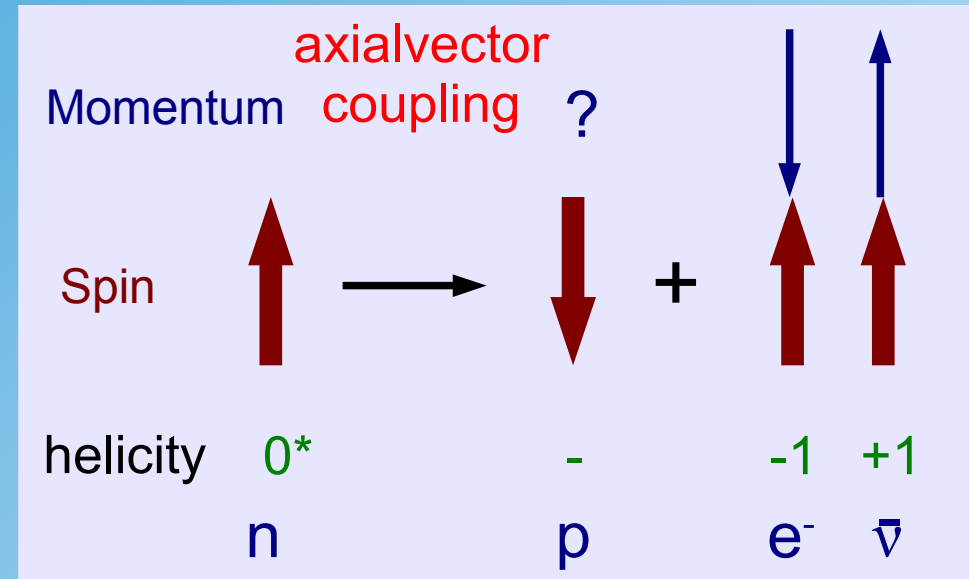
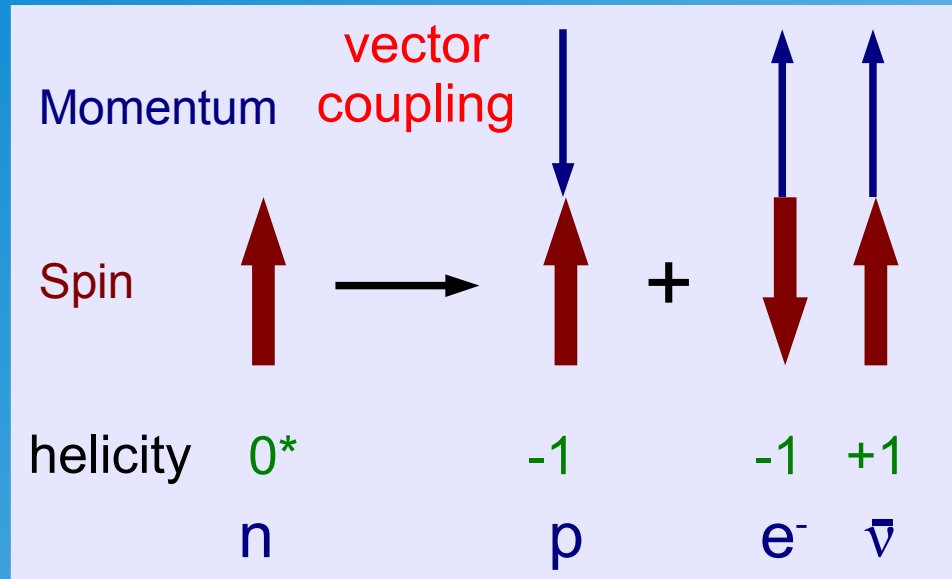

Test of Lorentz Structure?

Fermi transition RH anti-neutrino helicity Gamov Teller transition

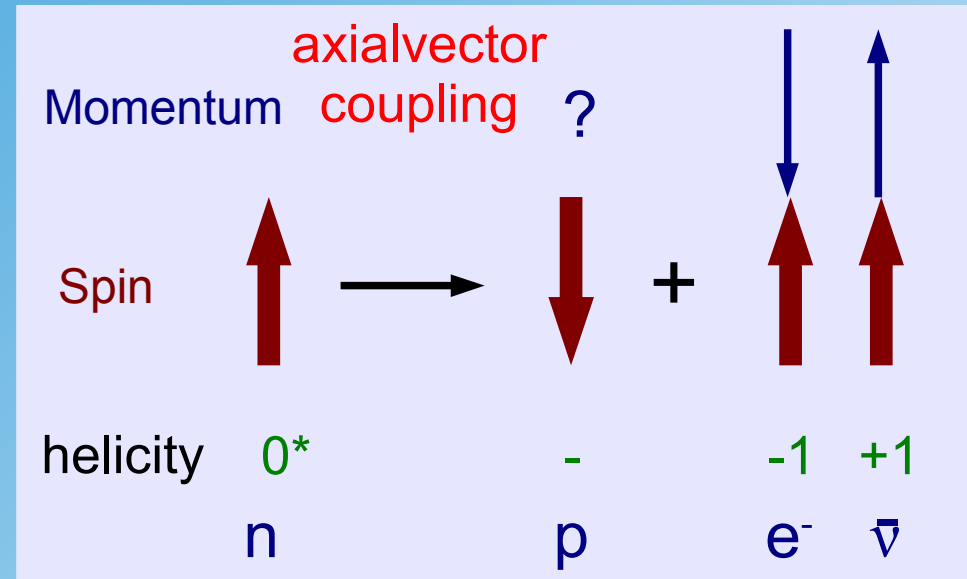
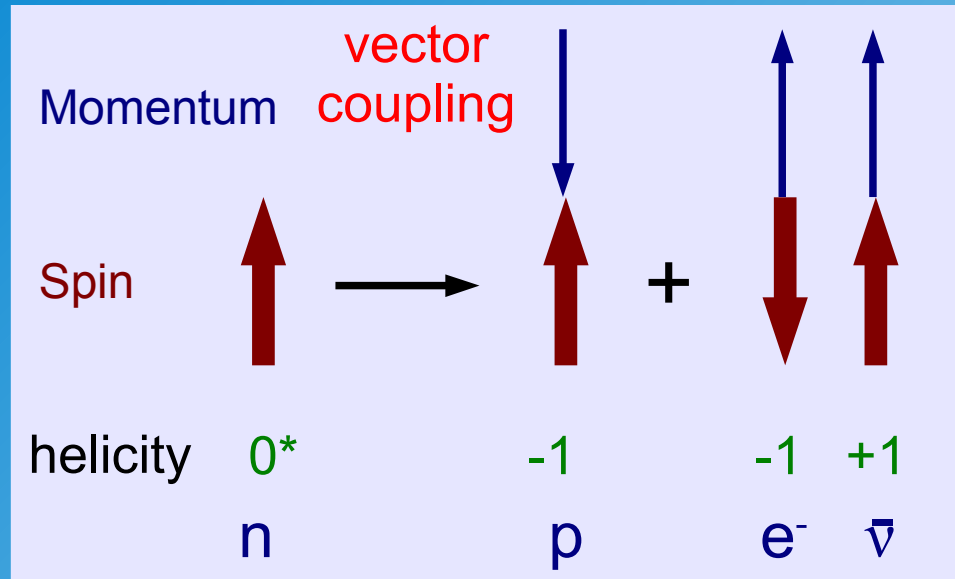

measure correlations of particle spins and directions:

- polarisations
- momenta (directions + energies)

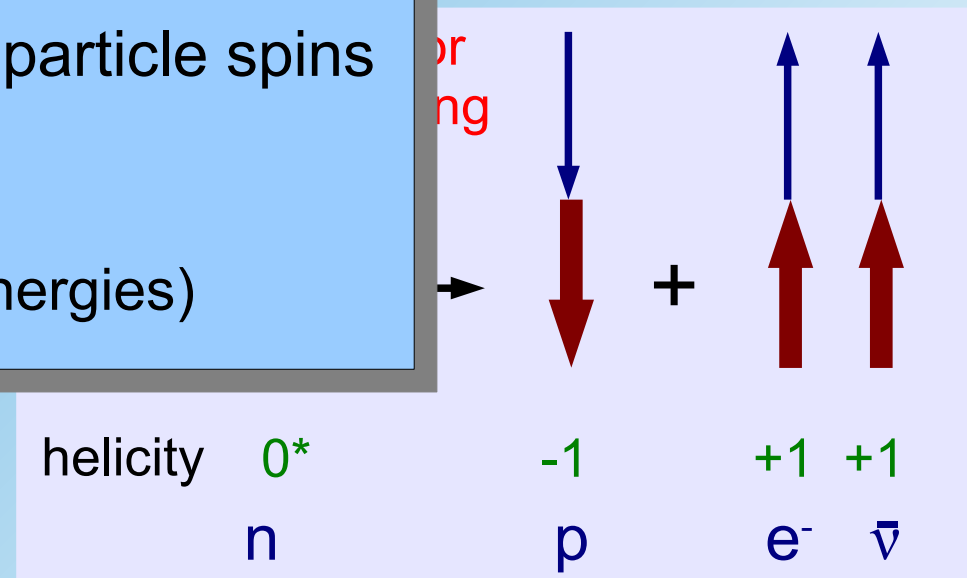
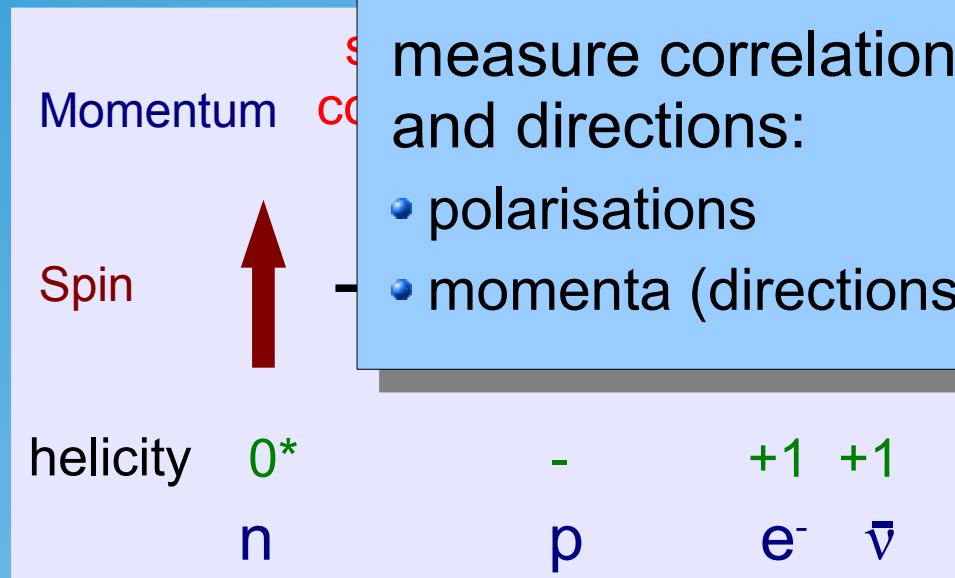

Important Experiments

- Wu-Experiment (1957): radioactive decay of Co^{60}
- Goldhaber-Experiment (1958): radioactive decay of Eu^{152}
- Muon Decay: Michel spectrum
- Pion Decay: branching ratios
- Neutrino Nucleon Scattering: neutrino-antineutrino
- Nuclear Beta Decays

Idea of the Wu-Experiment

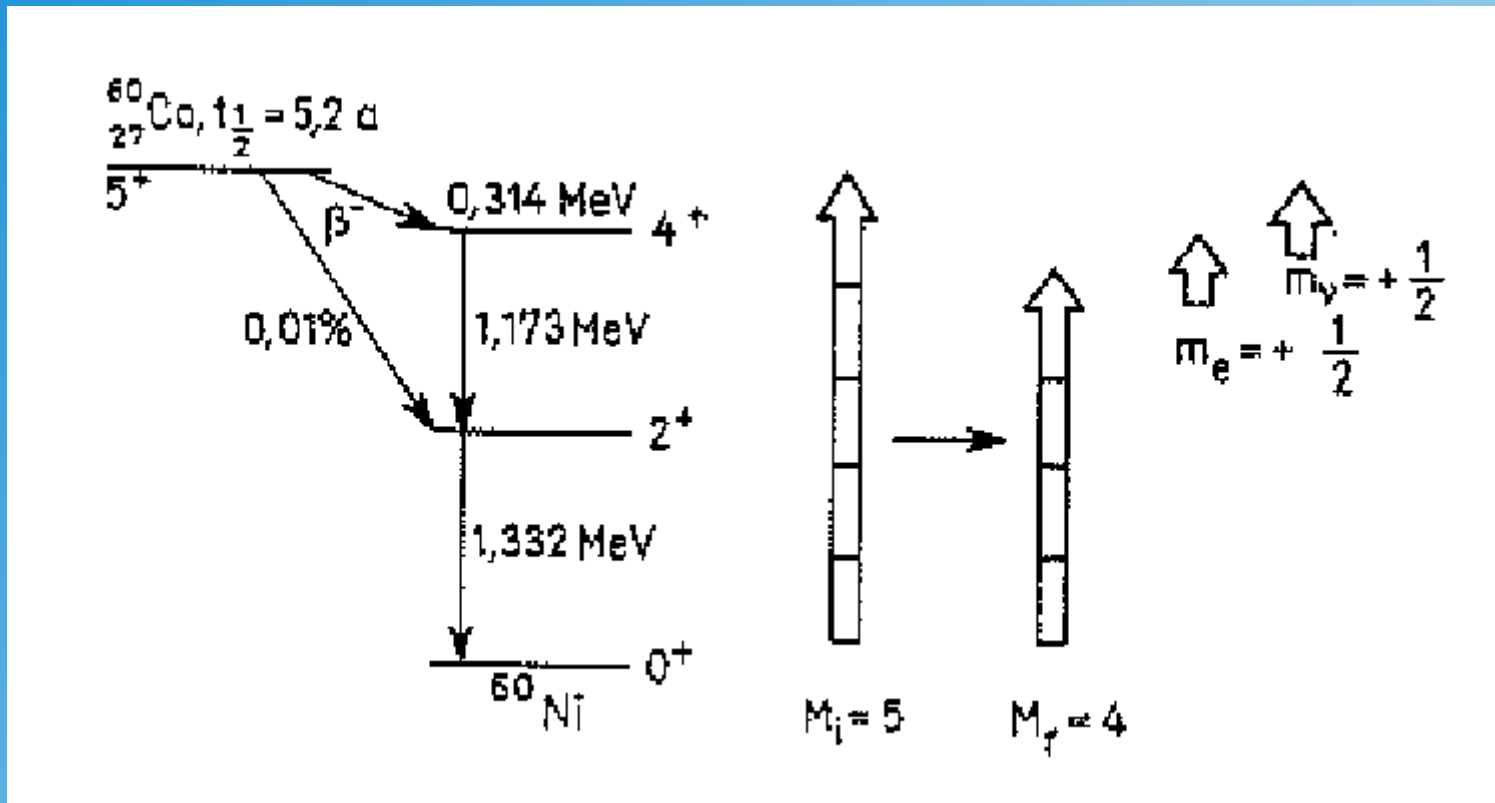

- High Spin of Cobalt leads to Gamov-Teller transition
- Polarisation of electron (neutrino)?

$$\lambda(e^-) = ?$$

Test of Lorentz Structure in ^{60}Co

Gamov Teller transitions

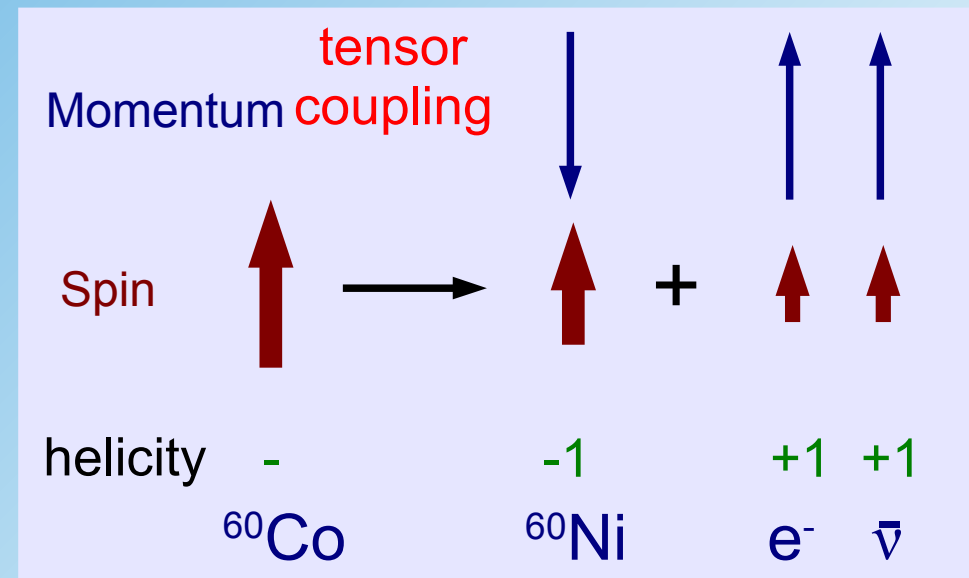
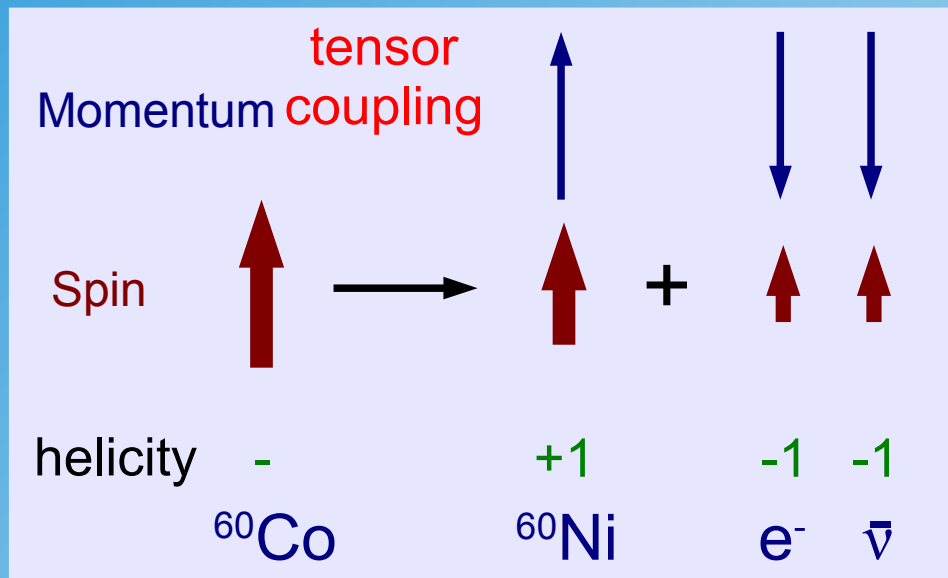
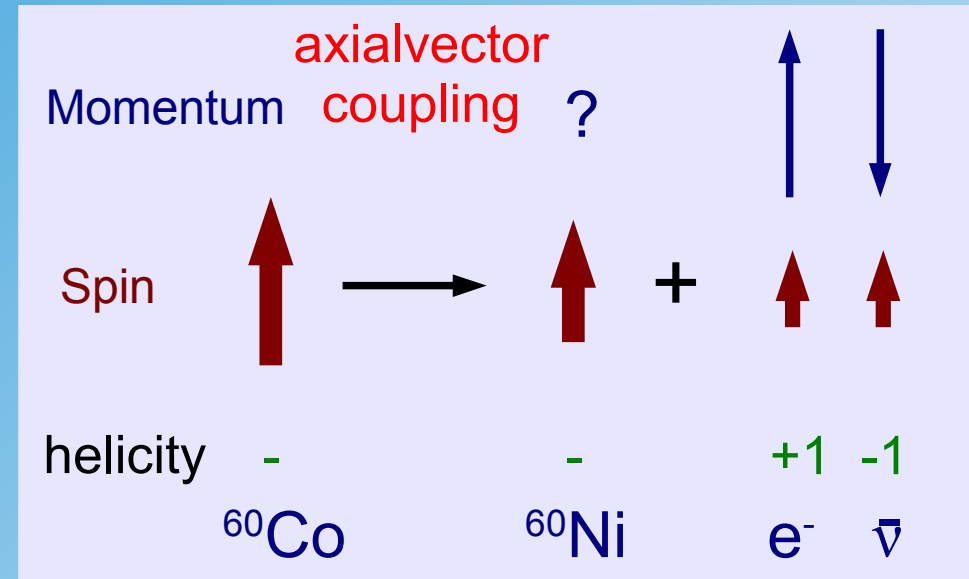
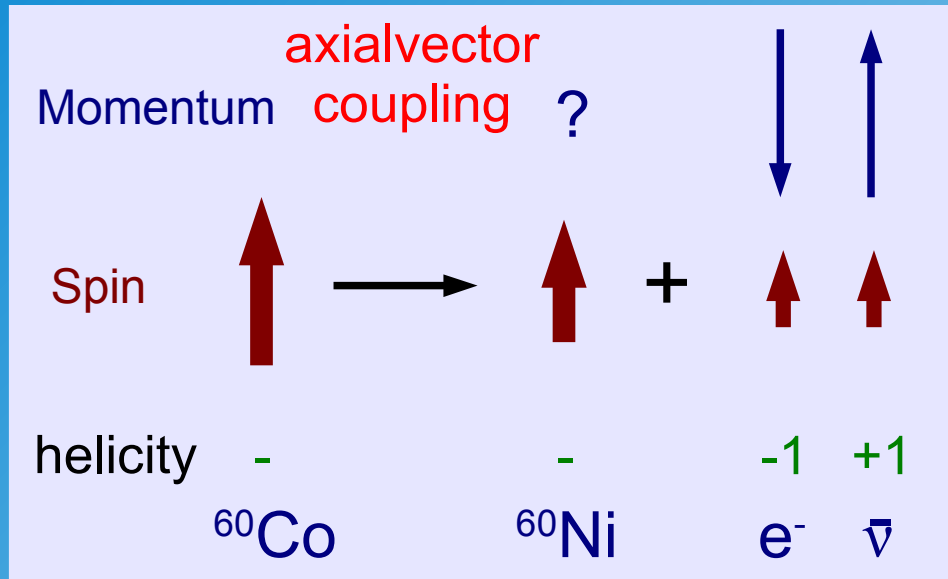

Measurement of the Ni*-Polarisation

important cross check!

- $^{60}\text{Ni}^*(J=4)$ is produced in an excited state!
- Beta Decay followed by photo-nuclear decay:

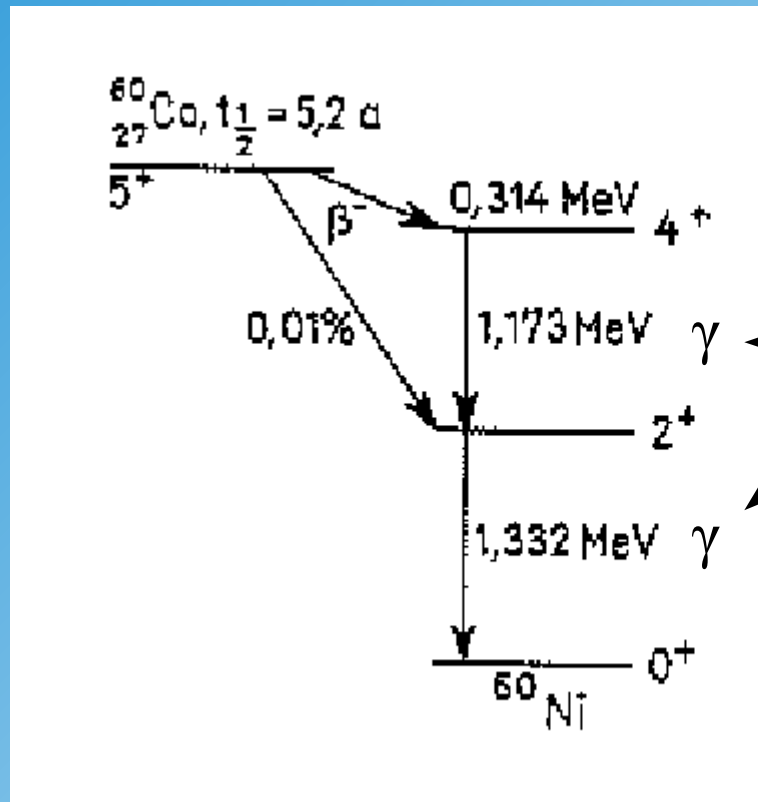
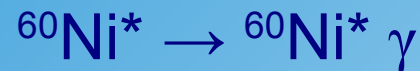

Photons are polarised and oriented (symmetrically) in direction of the Ni (Co) polarisation axis. Maximum is orthogonal to Ni (Co) polarisation

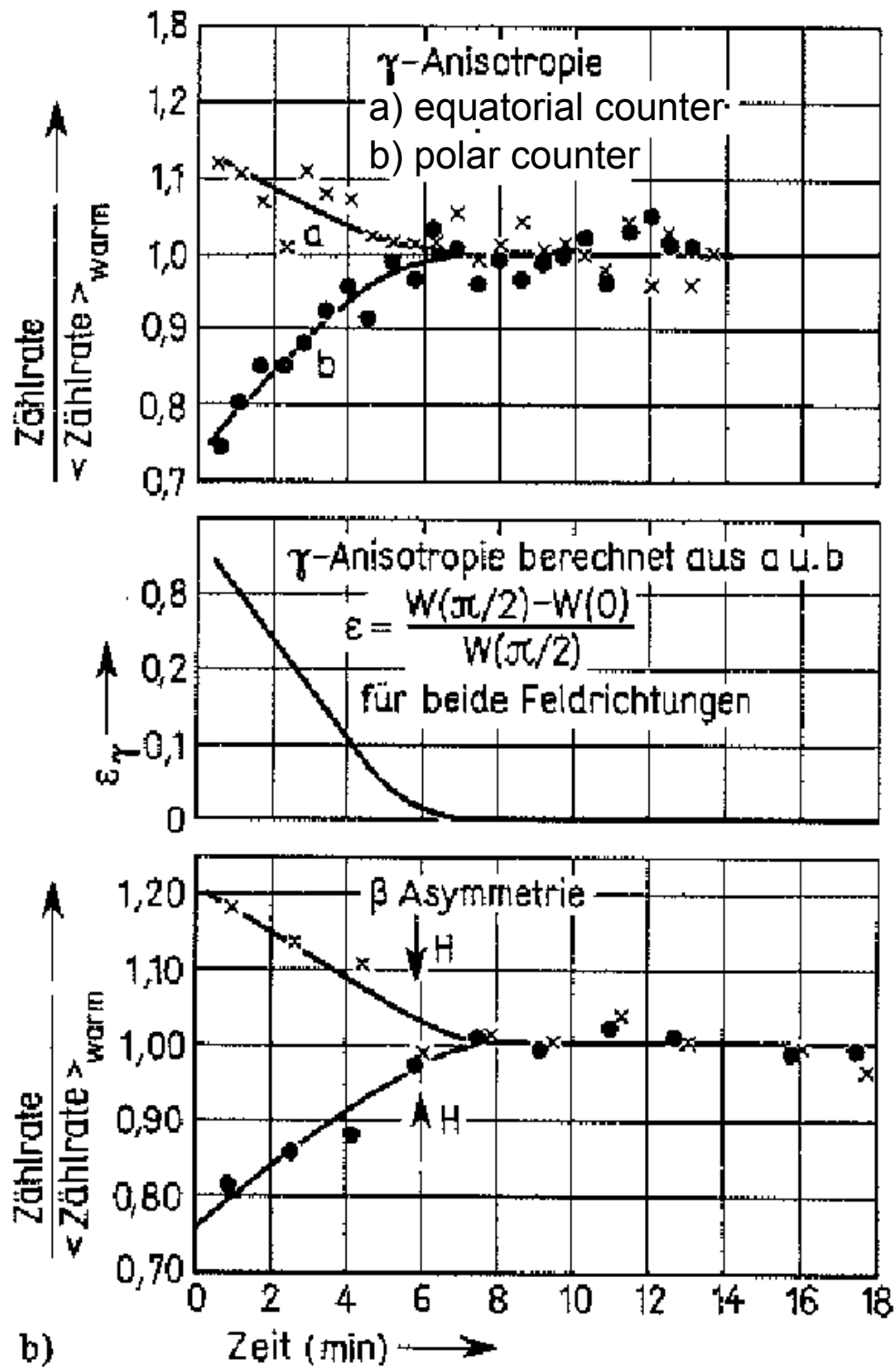
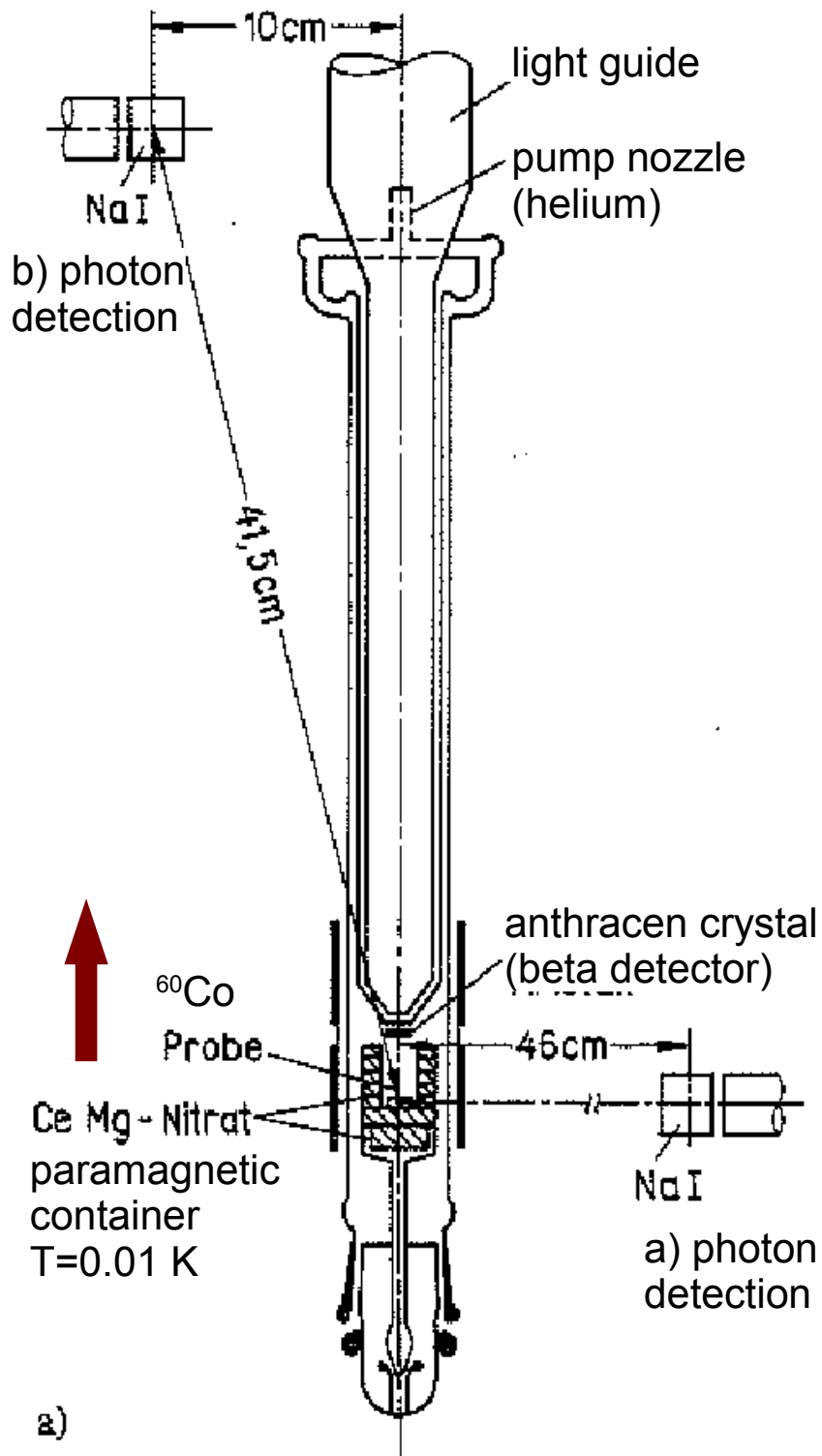

Conclusion Wu-Experiment

- Electrons are dominantly emitted opposite to Co spin direction
- Product $\mathbf{J} \cdot \mathbf{p} / |\mathbf{p}|$ (helicity) is non-zero!
- Helicity is negative!
- Discrete-Parity symmetry is violated (initial state had $H=0$)

Note: the angular distribution of the electrons is given by:

$$\frac{dN}{d \cos \theta} \propto 1 + A \cos \theta$$

Test of Lorentz Structure in ^{60}Co

Gamov Teller transitions

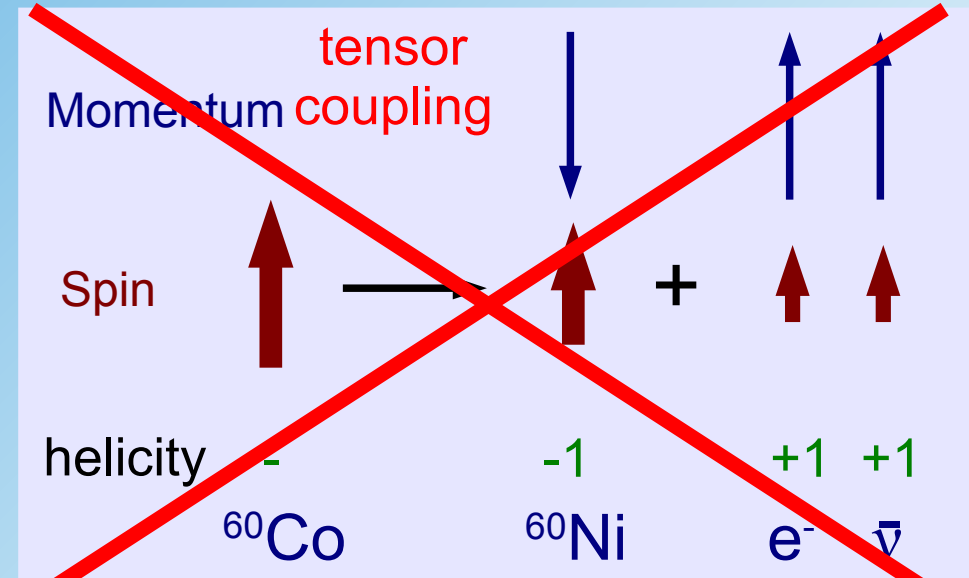
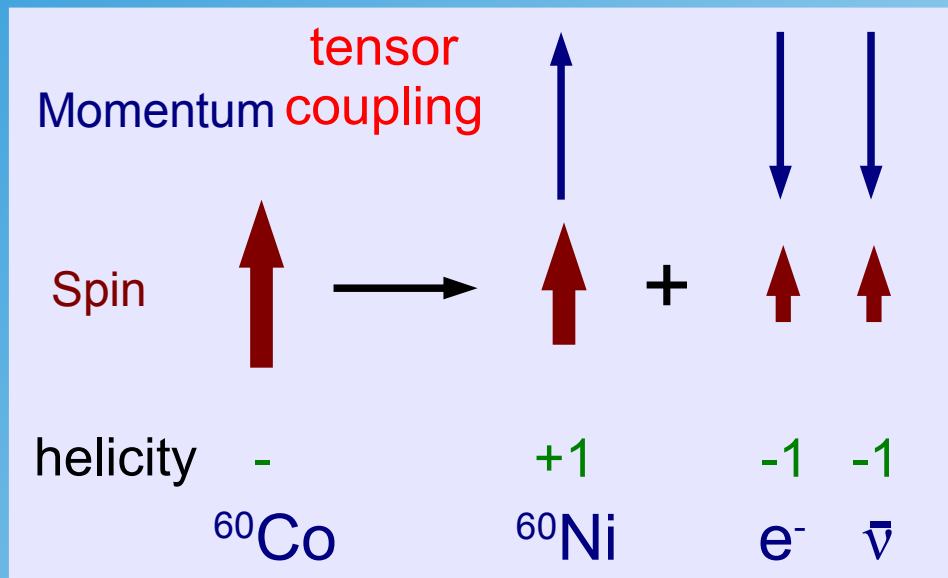
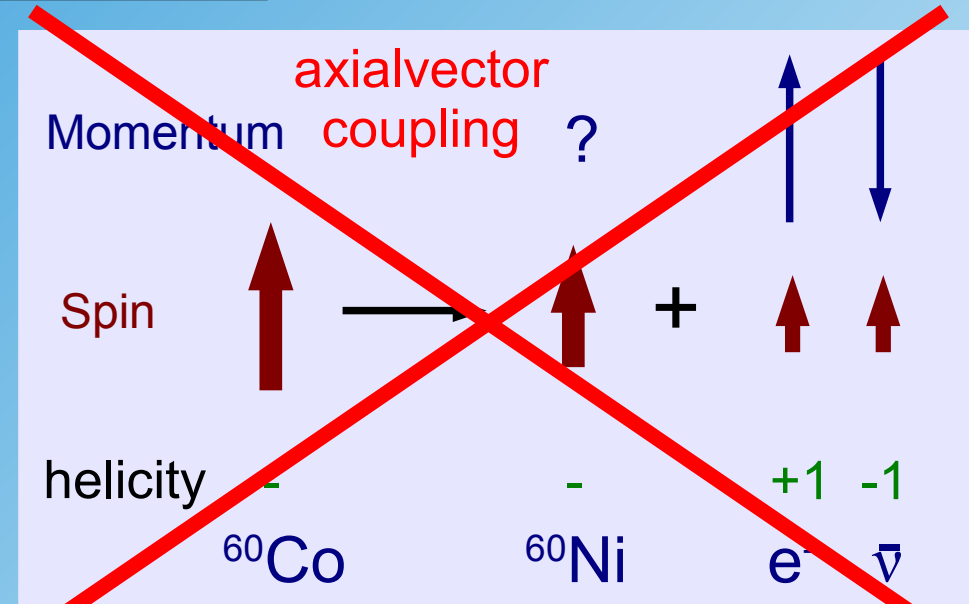
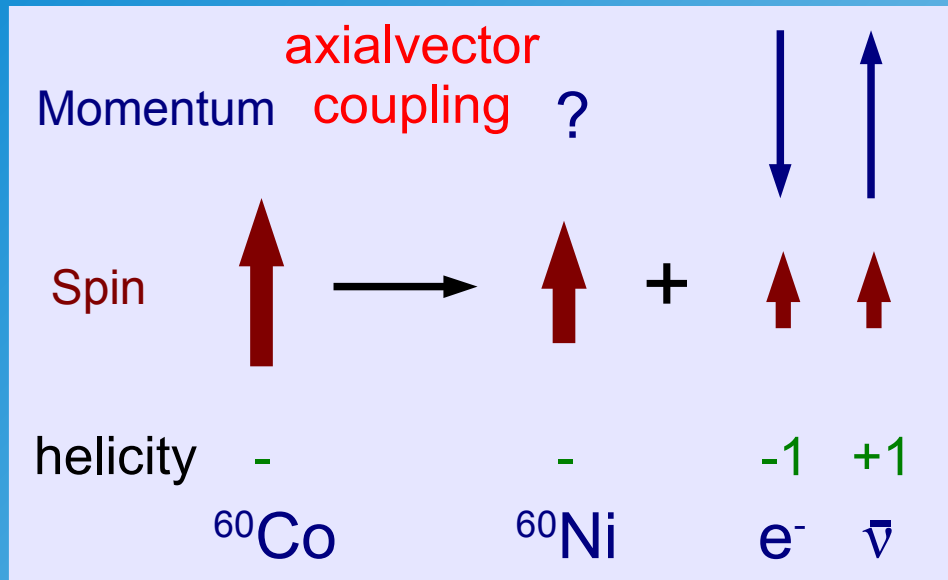

Test of Lorentz Structure in ^{60}Co

Gamov Teller transitions

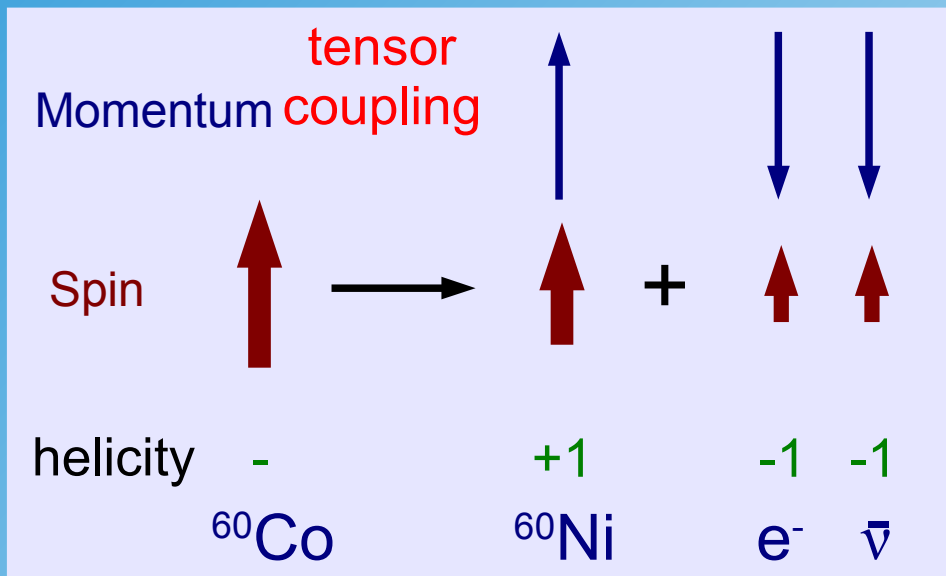
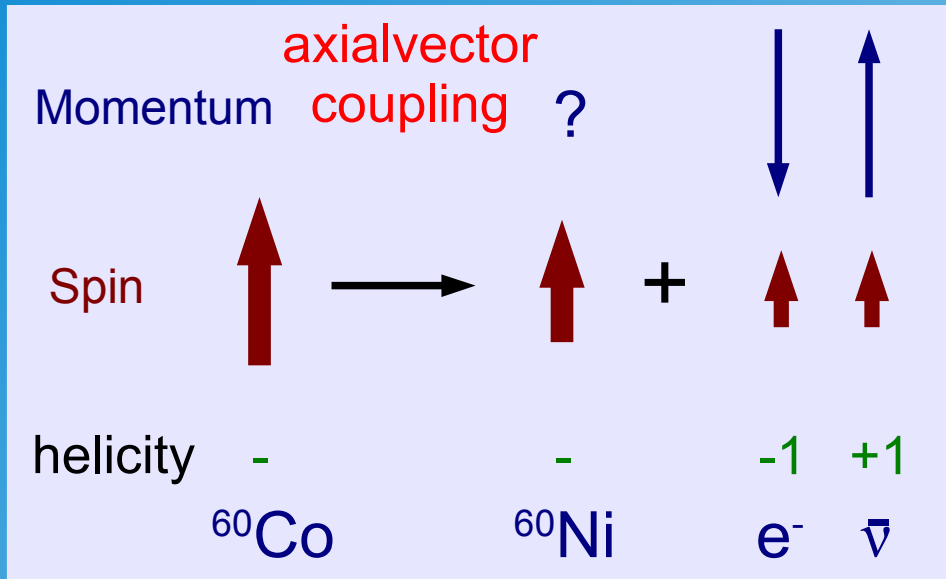

What about the neutrino helicity?

Europium Decay Chain

Lifetime $^{152}\text{Eu} = 13.5 \text{ a}$

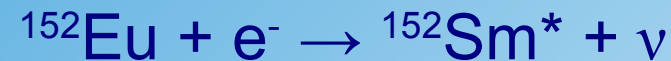
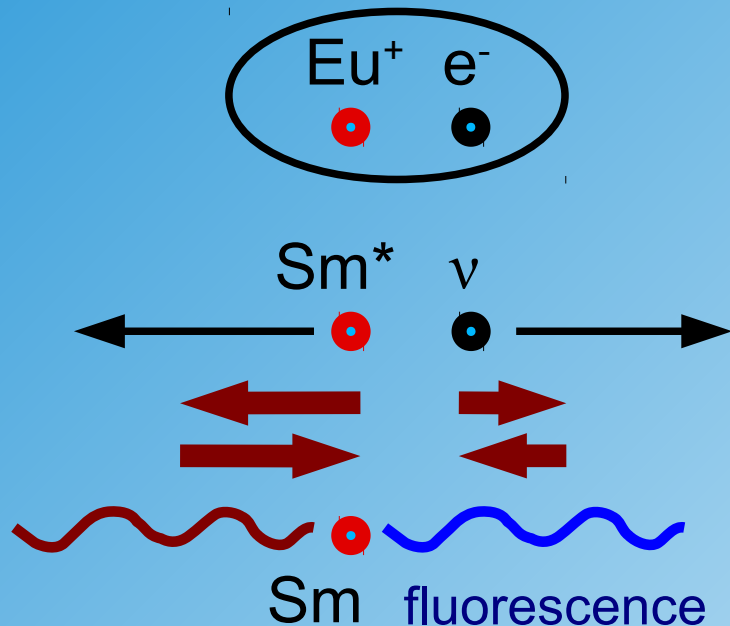
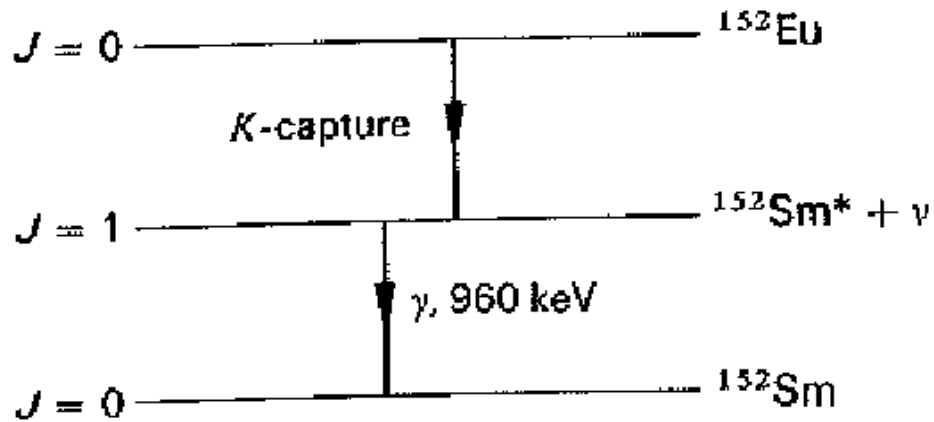

- Europium has no nuclear spin
- Polarisation of neutrino and Sm^* are opposite!
- The neutrino polarisation can be measured by determining the Sm^* polarisation
- Luckily Sm^* decays further:

$$\text{Sm}^* \rightarrow ^{152}\text{Sm} + \gamma$$
- photon is of low energy if emitted opposite to Sm^* flight direction
 - fluorescence
- exploit Compton scattering to determine photon polarisation

Goldhaber Experiment

Compton scattering

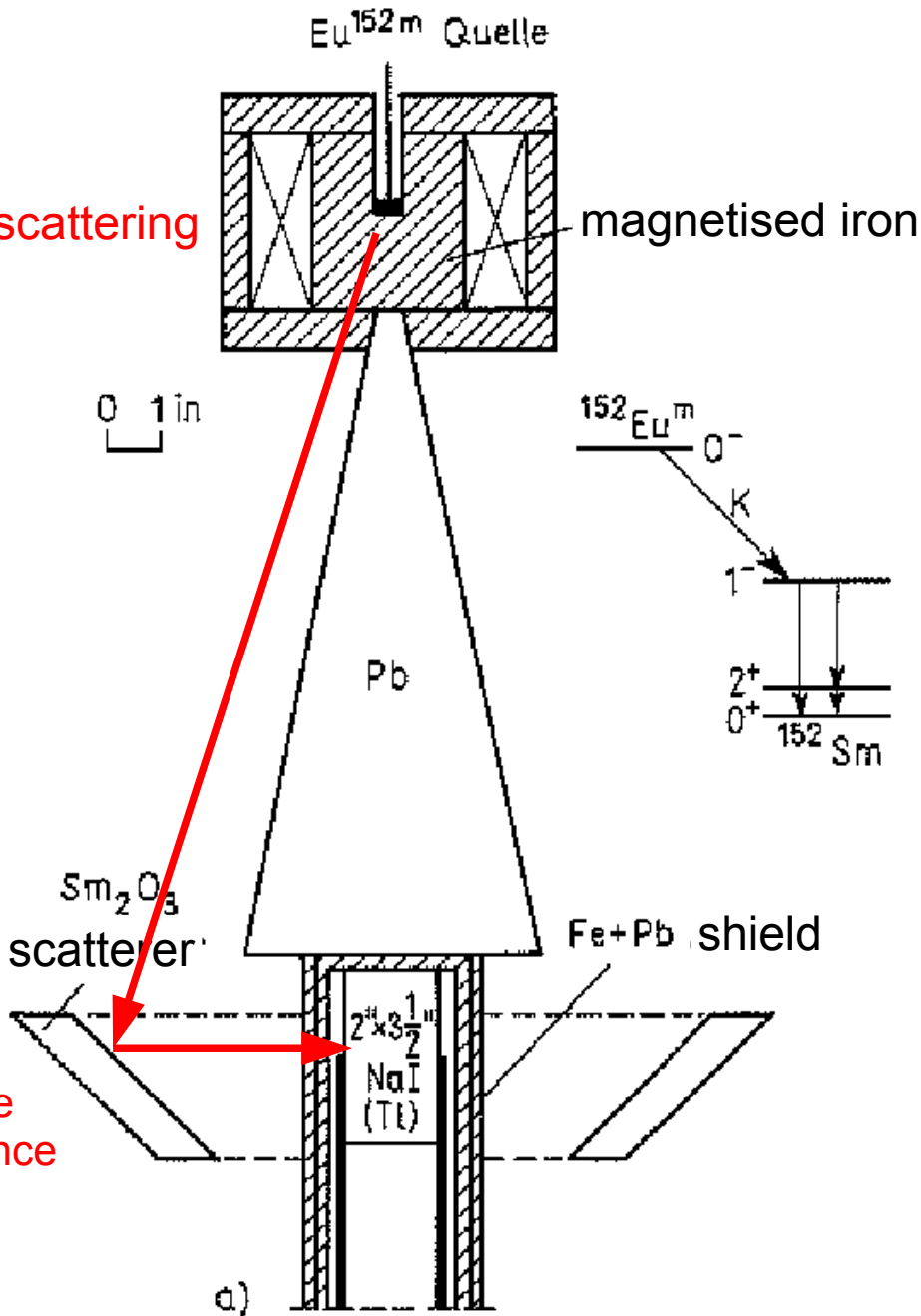

resonance fluorescence

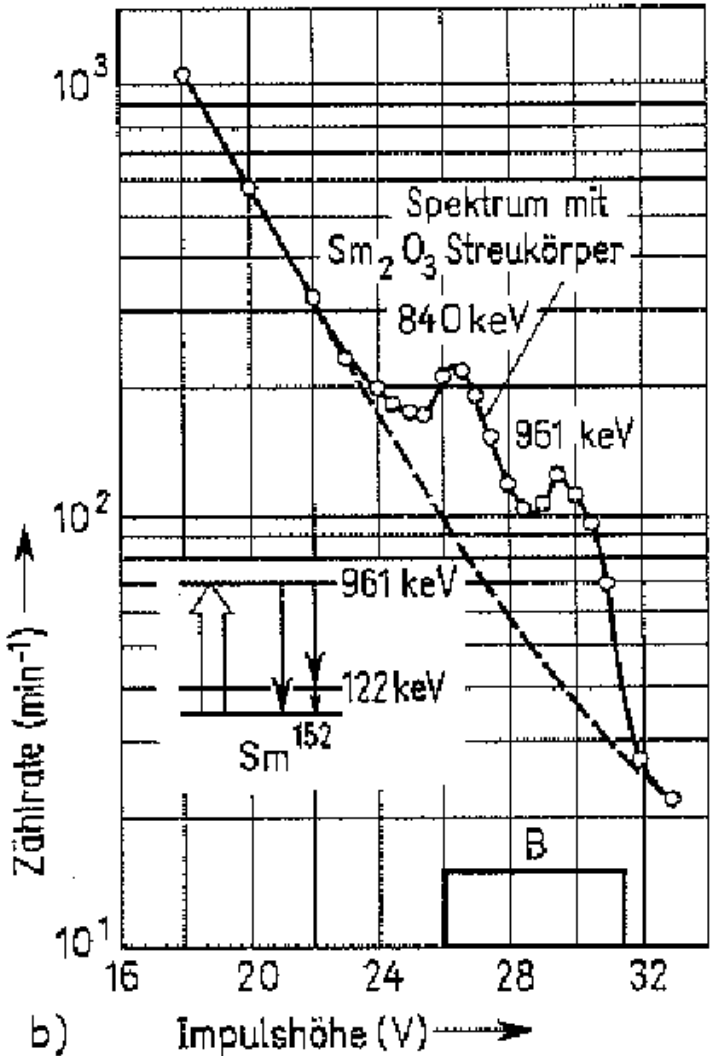

Fig. 144 a) Anordnung zur Messung der Helizität des Neutrinos (Goldhaber u. Mitarbeiter; b) Impulsverteilung für das γ -Streuspektrum. Gestrichelt: nicht-resonanter Untergrund; nach [Gol 58]

Goldhaber: Result + Conclusion

- Due to the ingenious construction of the experiment the polarisation of the photon corresponds to the polarisation of the neutrino
- The photon helicity was measured to be left-handed!
- As a result the helicity of the neutrino has to be left handed
- Left-handed chiral (neutrino!) fermion couplings can be described either by V-A coupling or T(P)-S couplings.
- T(P)-S couplings excluded by Wu- and Goldhaber-experiments

Test of Lorentz Structure in ^{60}Co

Gamov Teller transitions

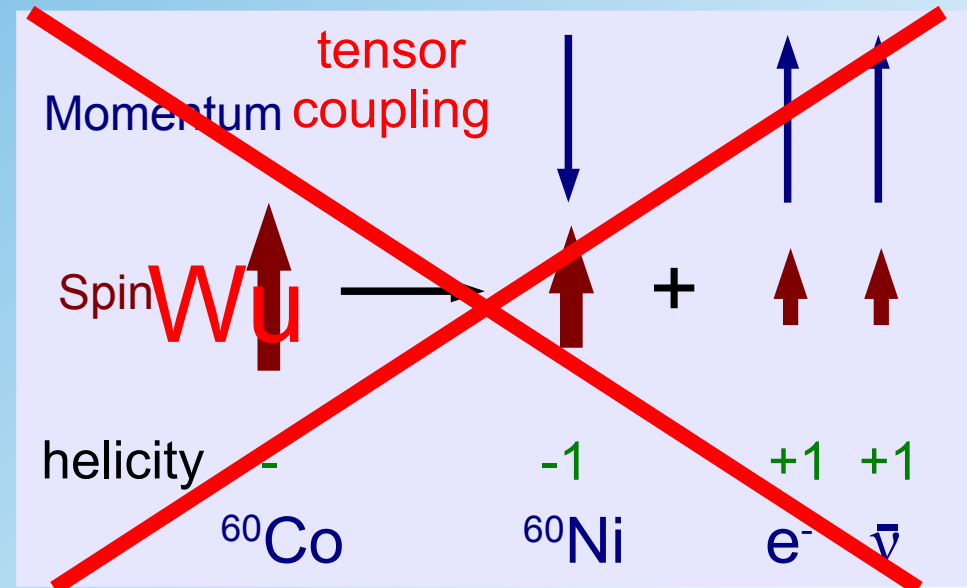
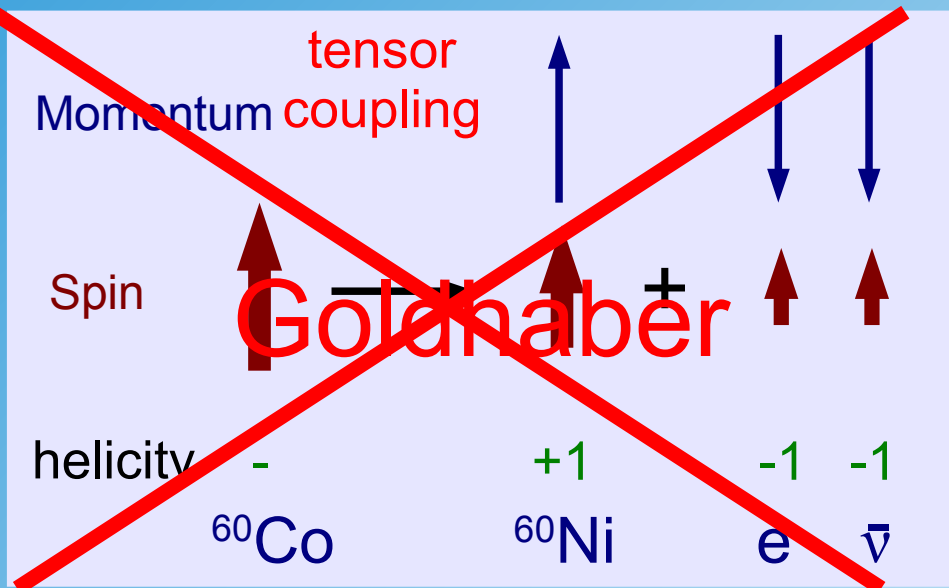
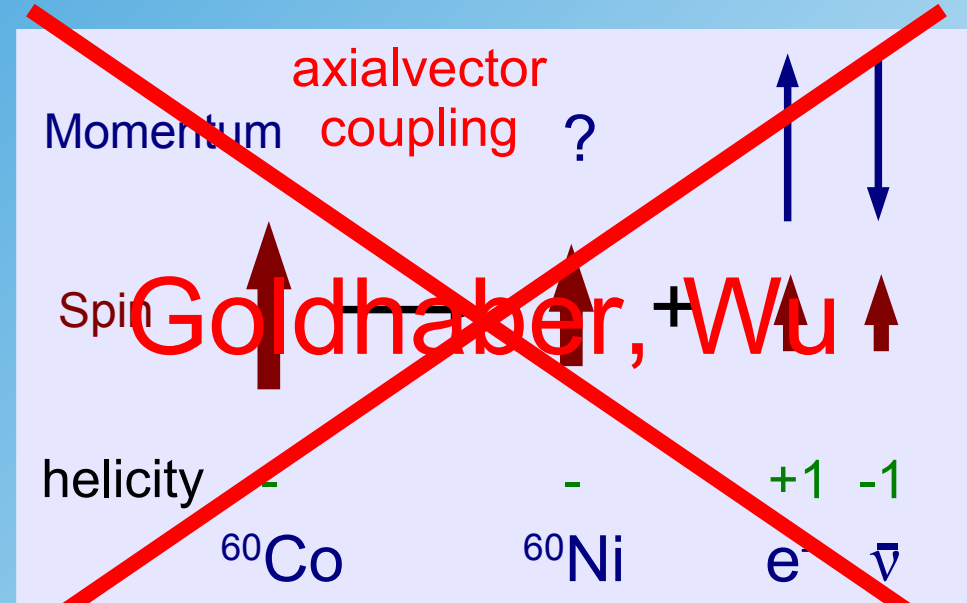
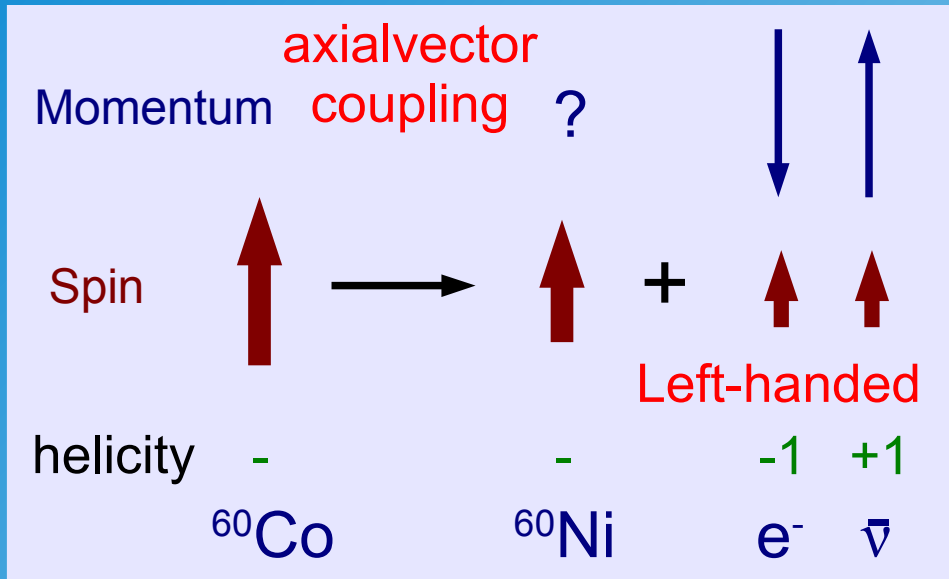

Mott Scattering for Polarisation Measurements

reaction: $e N \rightarrow e N$ is polarisation dependent:
coupling of spin and orbital momentum \rightarrow left-right asymmetry

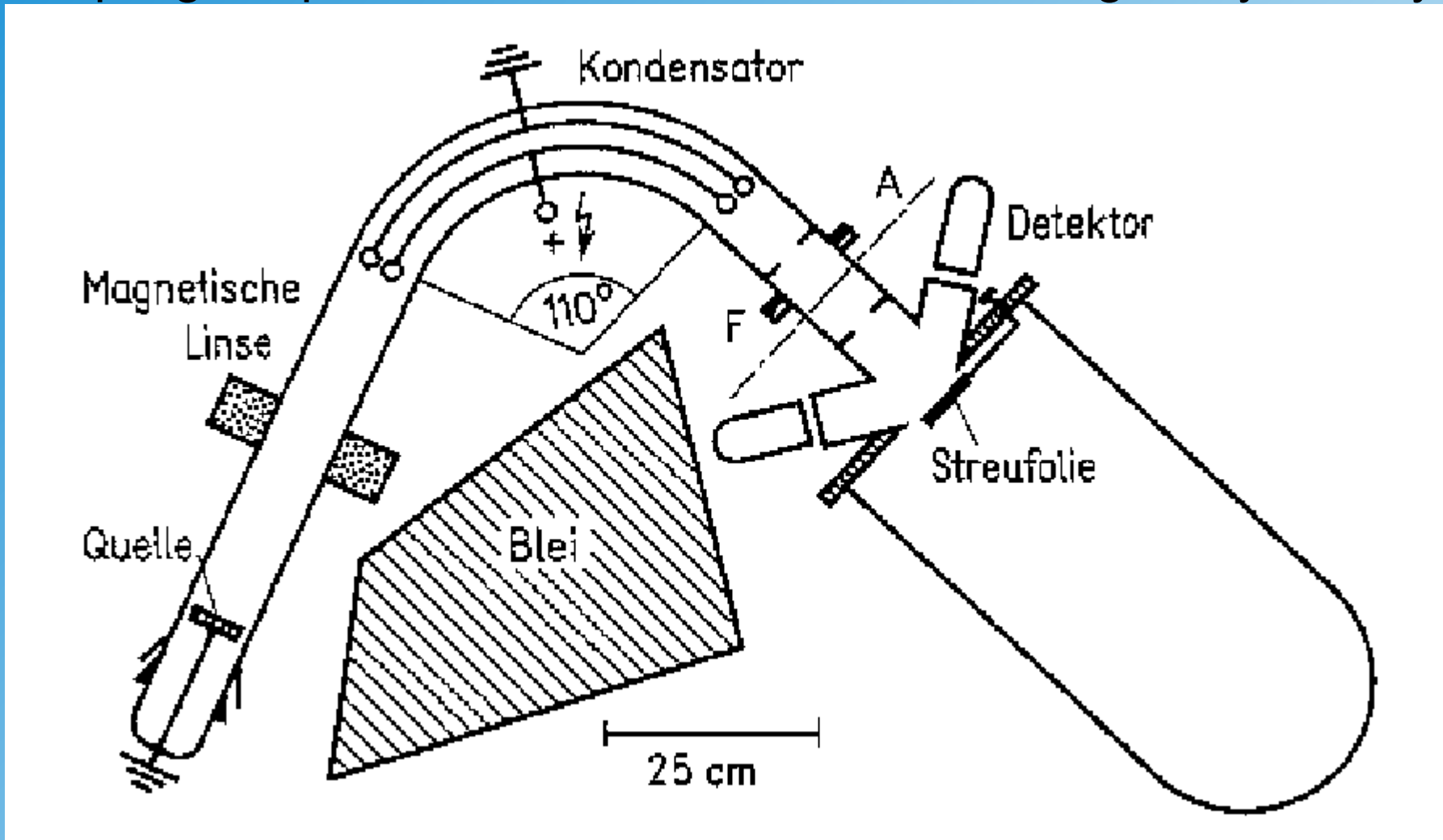

Polarisation in Beta Decays

polarisation: $P = \frac{N(+\frac{1}{2}) - N(-\frac{1}{2})}{N(+\frac{1}{2}) + N(-\frac{1}{2})}$ in different radioactive decays:

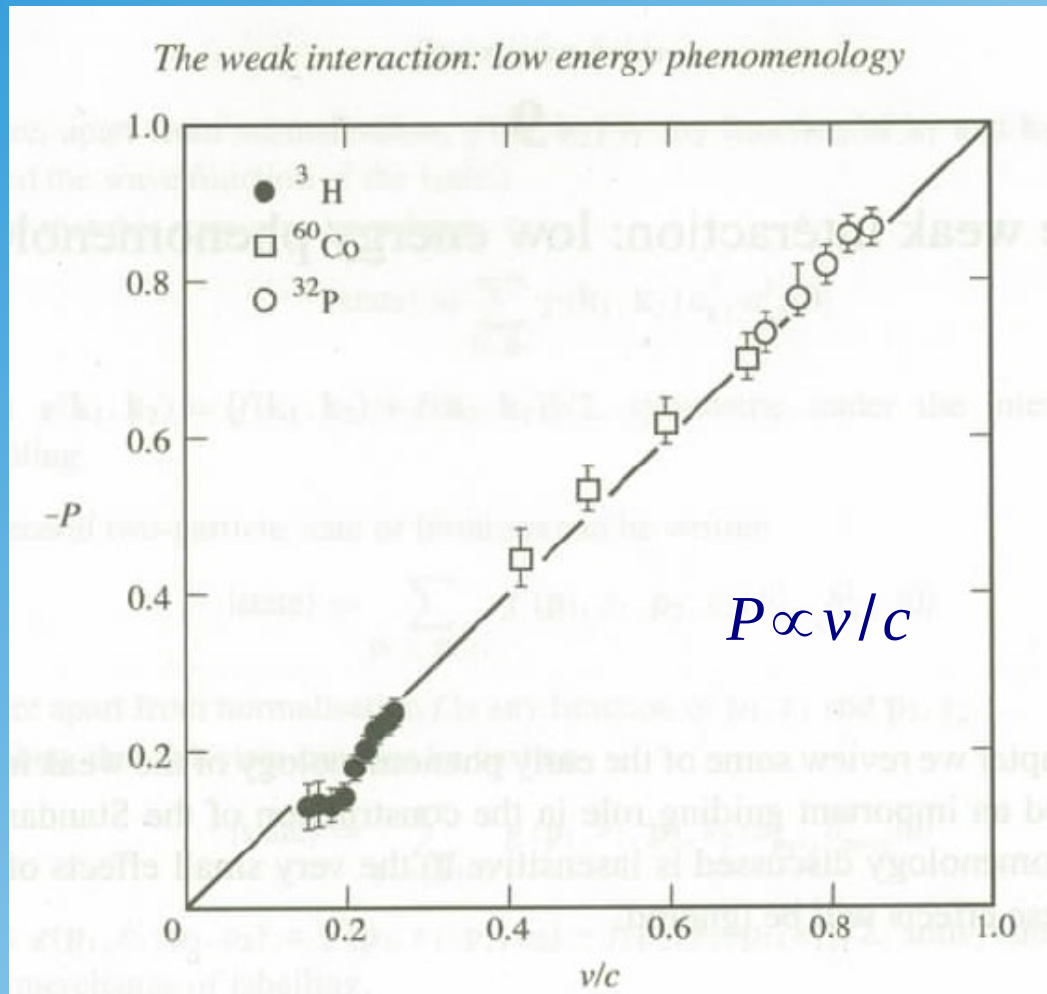

only left-handed particles!

Myon Decay

- classical 3-body decay $\mu \rightarrow e \bar{\nu}_e \nu_\mu$
- only left handed particles interact

$$L = \frac{G}{\sqrt{2}} (\bar{f} \Gamma f') (\overline{f''} \tilde{\Gamma} f''') \quad \text{with} \quad \Gamma_\mu = \gamma_\mu (1 - \gamma_5)$$

Lorentz Structure in Muon Decay

Fermi transition

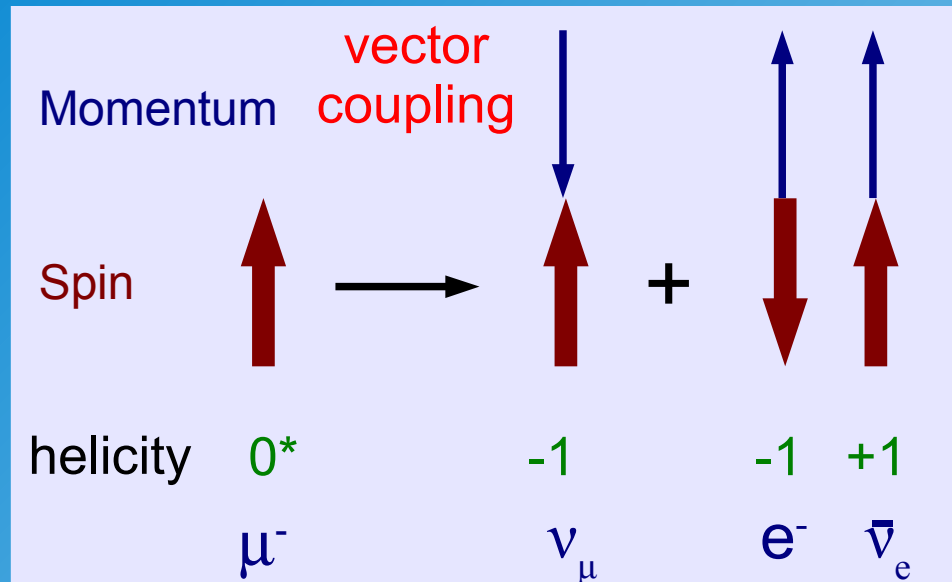

Gamov Teller transition

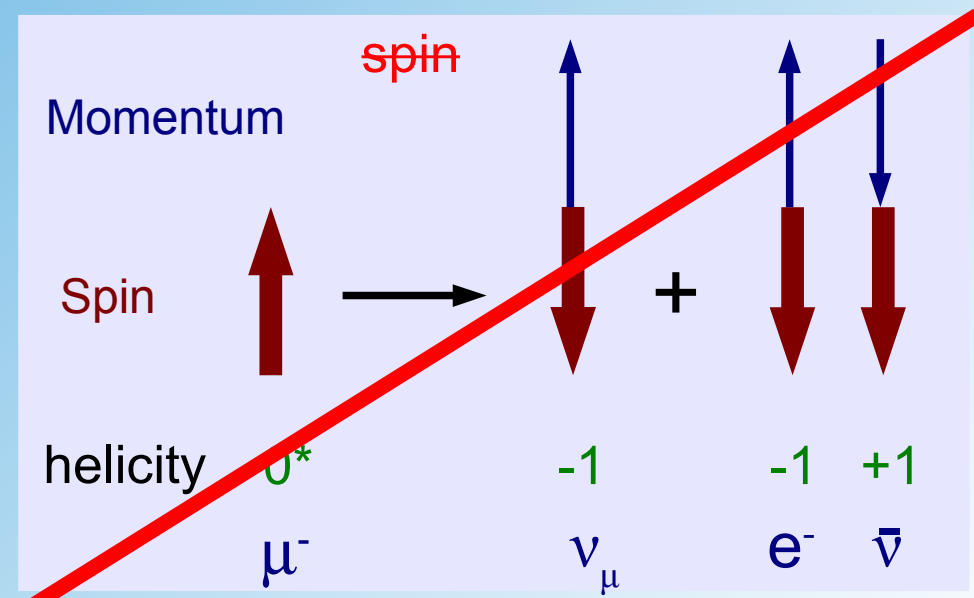
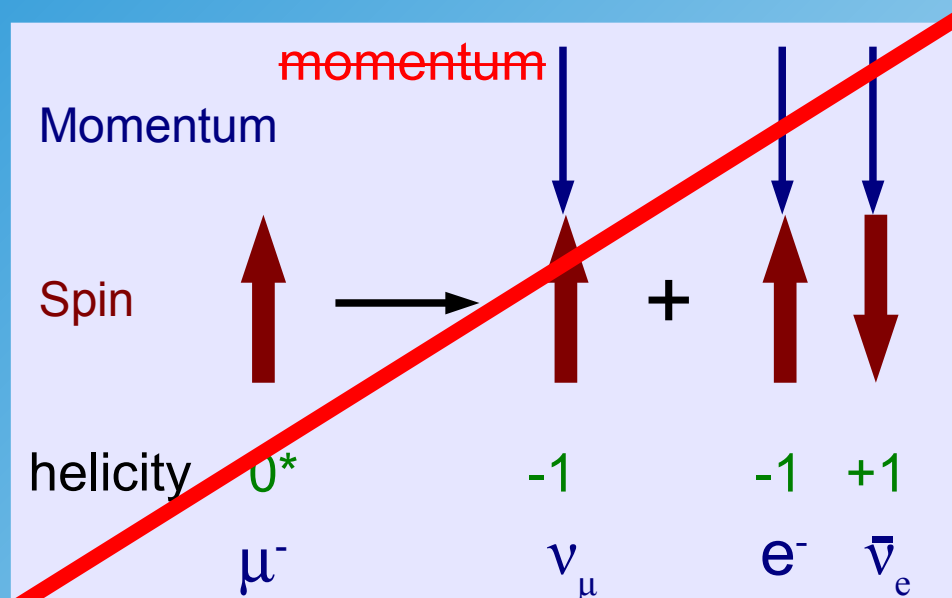
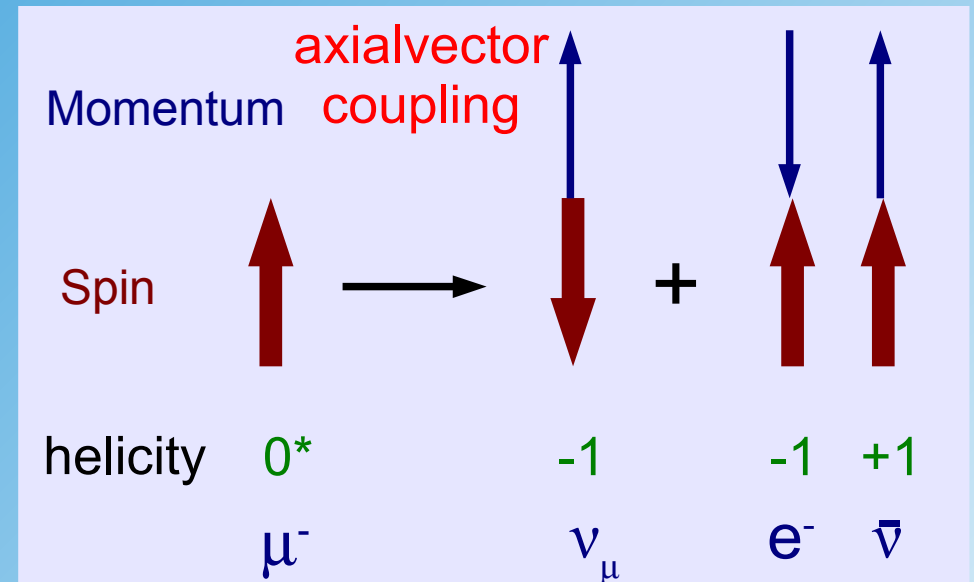

Lorentz Structure in Muon Decay

Fermi transition

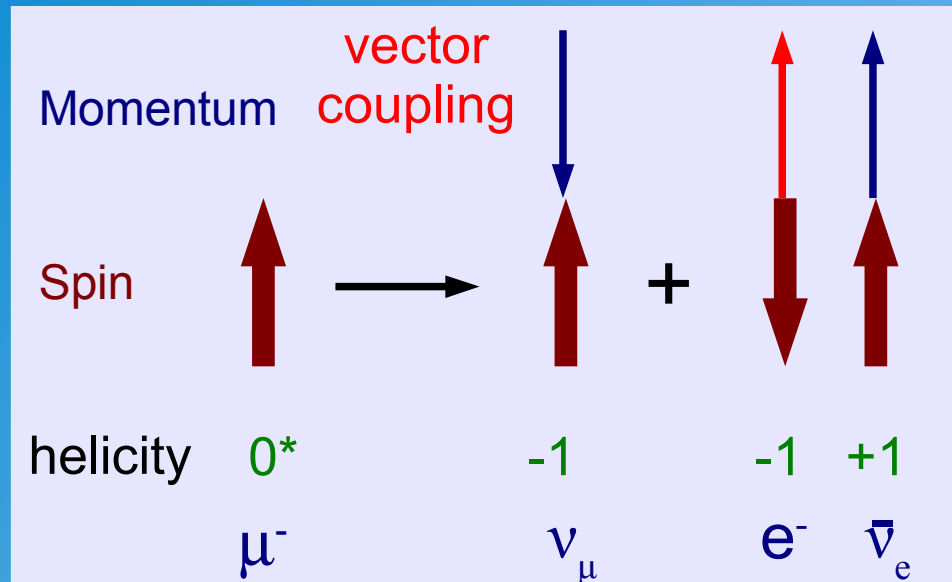

muon neutrino has highest energy

Gamov Teller transition

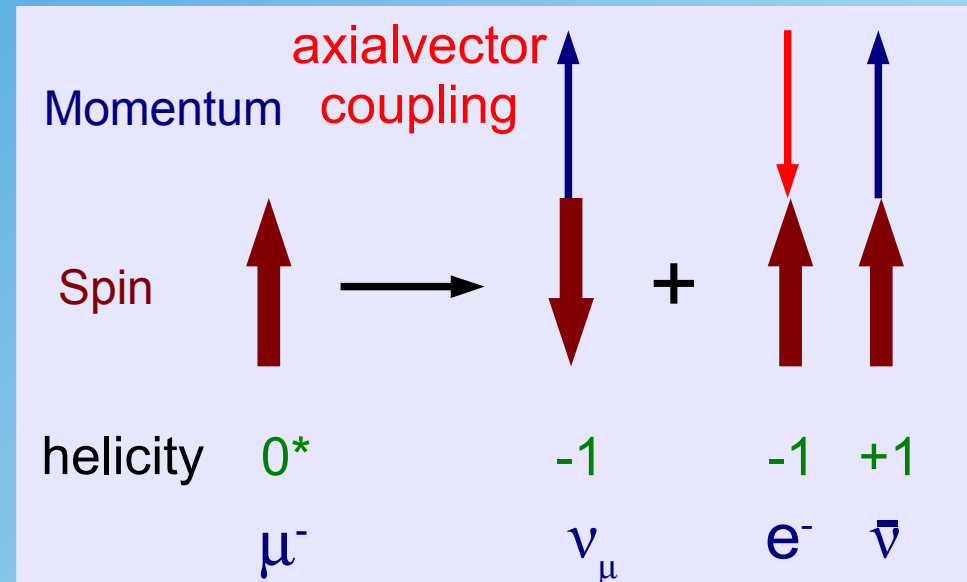

electron has highest energy

From helicity considerations, the electron is expected to have in average an energy of $3/4$ of half the muon mass $\rightarrow 3/8$ (exact: $7/10$) in contrast to $1/3$ naively expected from kinematics

\rightarrow Michel spectrum

Michel-Spectrum

$$\frac{d^2\Gamma}{dx d\cos\vartheta} = \frac{G_F^2 m_\mu^5}{192\pi^3} [3 - 2x \pm P_\mu \cos\vartheta(2x - 1)] x^2$$

$$x \equiv 2E_e/m_\mu$$

Very good agreement
between measurement
and SM prediction
(V-A) theory

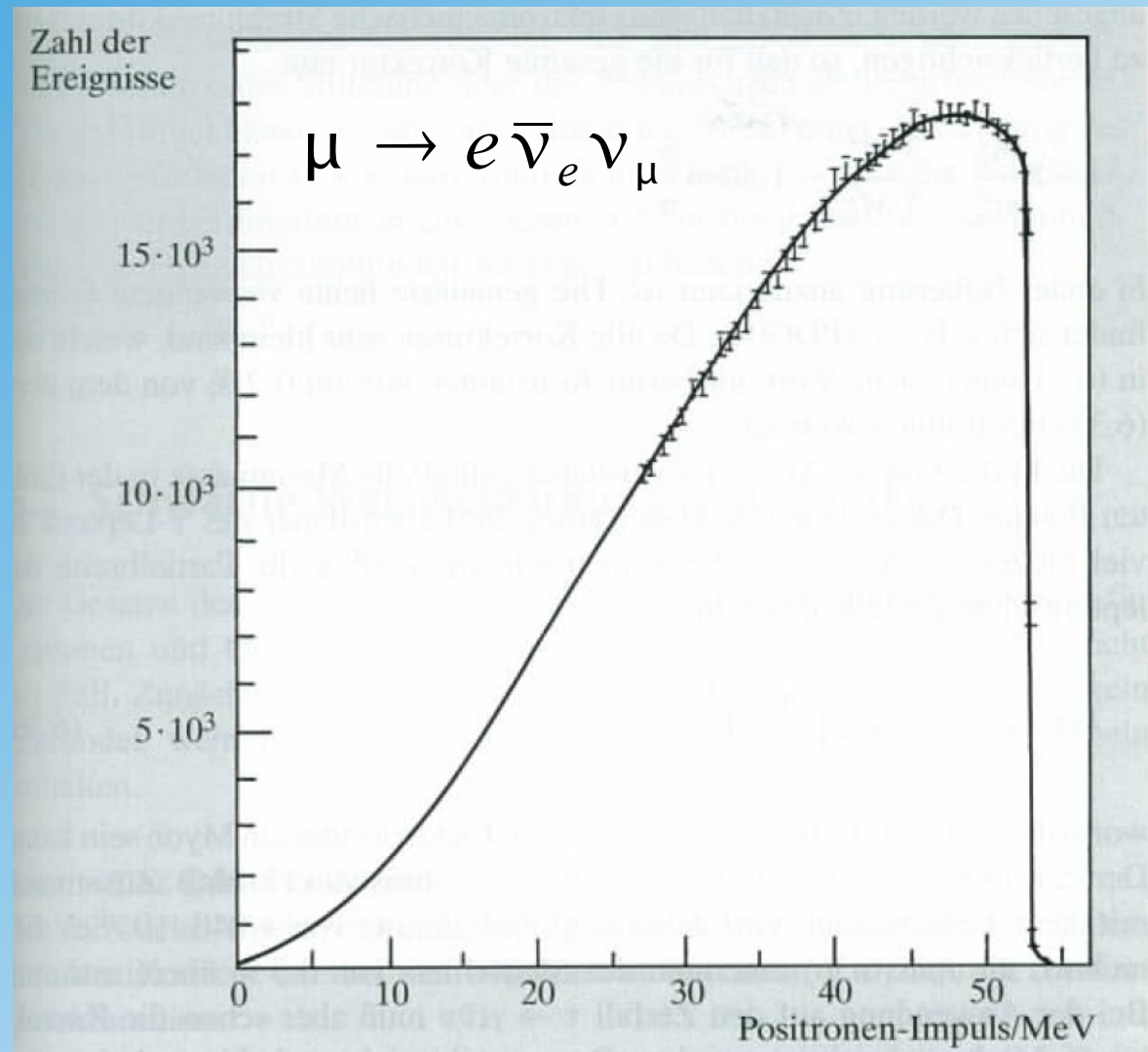

Michel-Spectrum beyond the SM

The muon decay is one of the best SM testing grounds:

Extended Michel spectrum formula:

$$\frac{d^2\Gamma}{dx d\cos\vartheta} \sim x^2 \cdot \left\{ 3(1-x) + \frac{2\rho}{3}(4x-3) + 3\eta x_0(1-x)/x \right. \\ \left. \pm P_\mu \cdot \xi \cdot \cos\vartheta \left[1-x + \frac{2\delta}{3}(4x-3) \right] \right\} \cdot \quad (2) \quad x_0 = \frac{2m_e m_\mu}{m_e^2 + m_\mu^2}$$

Important parameters: $\rho = \xi\delta = 3/4, \xi = 1, \eta = 0$

They can be related to
4-fermion couplings

$$L = \frac{G}{\sqrt{2}} (\bar{f} \Gamma f') (\bar{f}'' \tilde{\Gamma} f''')$$

Confirmation of V-A coupling

Experimental results:

$ g_{RR}^S < 0.062$	$ g_{RR}^V < 0.031$	$ g_{RR}^T \equiv 0$
$ g_{LR}^S < 0.074$	$ g_{LR}^V < 0.025$	$ g_{LR}^T < 0.021$
$ g_{RL}^S < 0.412$	$ g_{RL}^V < 0.104$	$ g_{RL}^T < 0.103$
$ g_{LL}^S < 0.550$	$ g_{LL}^V > 0.960$	$ g_{LL}^T \equiv 0$
$ g_{LR}^S + 6g_{LR}^T < 0.143$	$ g_{RL}^S + 6g_{RL}^T < 0.418$	
$ g_{LR}^S + 2g_{LR}^T < 0.108$	$ g_{RL}^S + 2g_{RL}^T < 0.417$	
$ g_{LR}^S - 2g_{LR}^T < 0.070$	$ g_{RL}^S - 2g_{RL}^T < 0.418$	

Test Charged Pion Branching Ratios

- dominant decay: $B(\pi^+ \rightarrow \mu^+ \nu) = 99.9877 \%$
- suppressed decay: $B(\pi^+ \rightarrow e^+ \nu) = 1.23 \cdot 10^{-4}$

Similar to the neutral pion in QED the more obvious decay is suppressed!

V-A Currents:

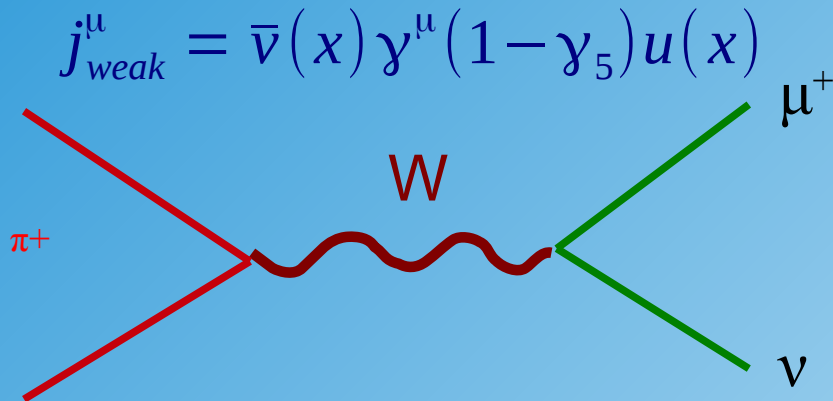

Polarisation of helicity state is given by fermion velocity:

$$\langle \lambda \rangle = -\beta \quad \text{for left chiral states}$$

- V-A currents conserve helicity.
- Resulting spin should be $J(\pi^+) = 1$
- But pion is a Pseudo-scalar $J(\pi^0) = 0$
 → helicity suppression

Decay width:

$$\Gamma(\pi^- \rightarrow \mu^-) = \frac{G_F^2}{8\pi} f_\pi^2 m_\pi m_\mu^2 \left(1 - \frac{m_\mu^2}{m_\pi^2}\right)$$

$$\frac{\Gamma(\pi^+ \rightarrow e^+)}{\Gamma(\pi^+ \rightarrow \mu^+)} = \frac{m_e^2 (1 - m_e^2/m_\pi^2)}{m_\mu^2 (1 - m_\mu^2/m_\pi^2)} \sim 10^{-4}$$

Measurement of $\pi^+ \rightarrow e^+ \nu$

(Britton PRL 68, 20, 1992, 3000)

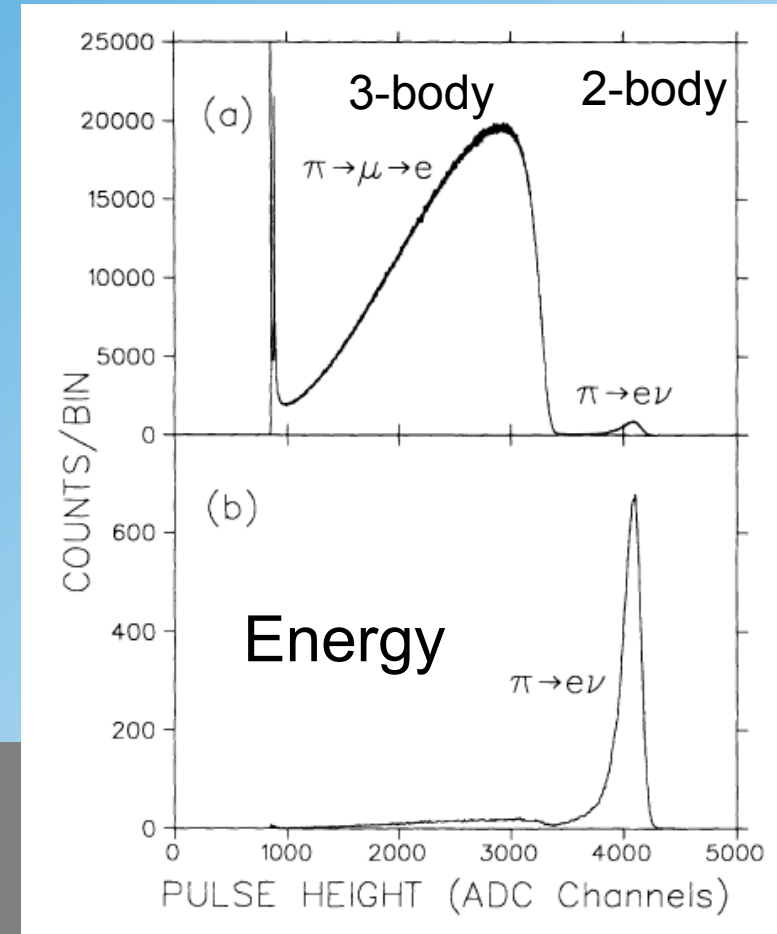
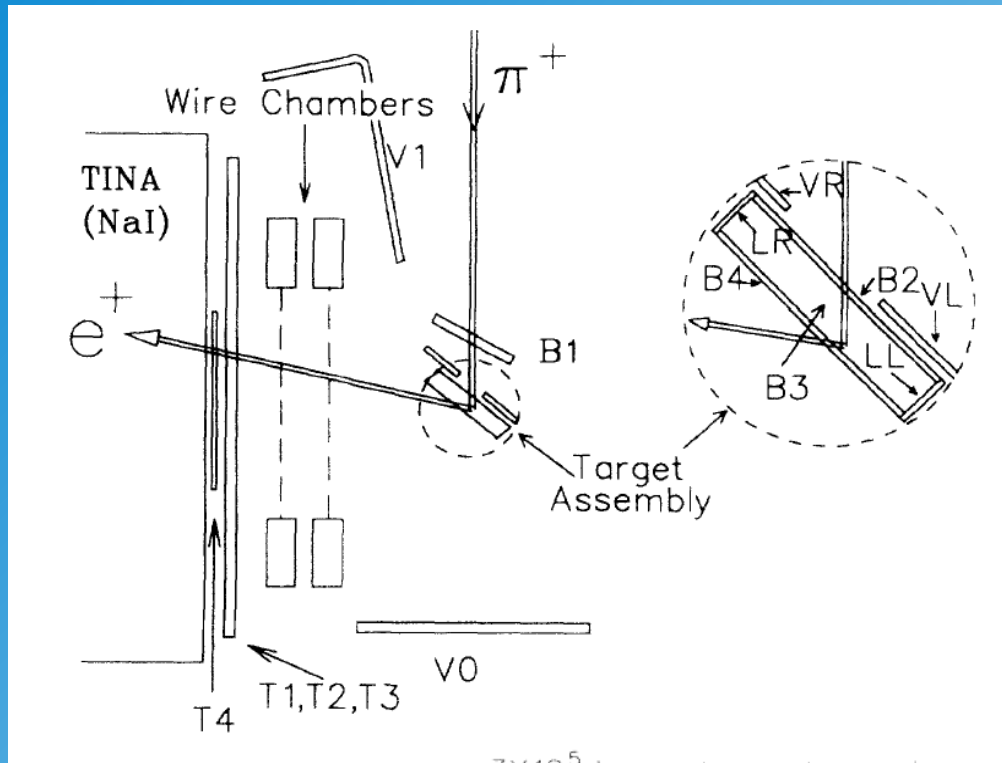

Pion lifetime 25 ns
 Muon lifetime 2 μ s

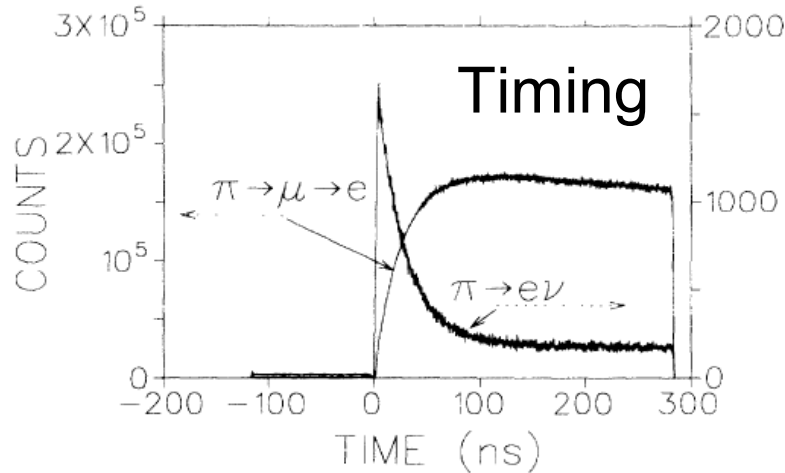

• Result:

$$B(\pi^+ \rightarrow e^+ \nu) = 1.23 \cdot 10^{-4}$$

Conclusion: **no scalar coupling!**

Gamma Matrices II

$$\gamma^0 = \begin{pmatrix} 1 & 0 & 0 & 0 \\ 0 & 1 & 0 & 0 \\ 0 & 0 & -1 & 0 \\ 0 & 0 & 0 & -1 \end{pmatrix}$$

$$\gamma^1 = \begin{pmatrix} 0 & 0 & 0 & 1 \\ 0 & 0 & 1 & 0 \\ 0 & -1 & 0 & 0 \\ -1 & 0 & 0 & 0 \end{pmatrix}$$

$$\gamma^2 = \begin{pmatrix} 0 & 0 & 0 & -i \\ 0 & 0 & i & 0 \\ 0 & i & 0 & 0 \\ -i & 0 & 0 & 0 \end{pmatrix}$$

$$\gamma^3 = \begin{pmatrix} 0 & 0 & 1 & 0 \\ 0 & 0 & 0 & -1 \\ -1 & 0 & 0 & 0 \\ 0 & 1 & 0 & 0 \end{pmatrix}$$

$$\gamma^5 = \begin{pmatrix} 0 & 0 & 1 & 0 \\ 0 & 0 & 0 & 1 \\ 1 & 0 & 0 & 0 \\ 0 & 1 & 0 & 0 \end{pmatrix}$$

(in other representations
 \mathfrak{g} is diagonal)

