

Lecture:

Standard Model of Particle Physics

Heidelberg SS 2012

Experimental Tests of QED Part 2

Overview

PART I

- Cross Sections and QED tests
- Accelerator Facilities + Experimental Results and Tests

PART II

- Tests of QED in Particle Decays
- QED Radiative Effects (Bremsstrahlung, Higher Order Processes)

Electromagnetic Decay of Pion

- Pion is the lightest hadron (meson)
- consists of u and d quarks (isospin triplet)
- No strong or weak decay possible

Can the electromagnetic decay of the pion be described by QED?

Complication: quarks are involve large QCD corrections!

Solution: introduce pion form factor

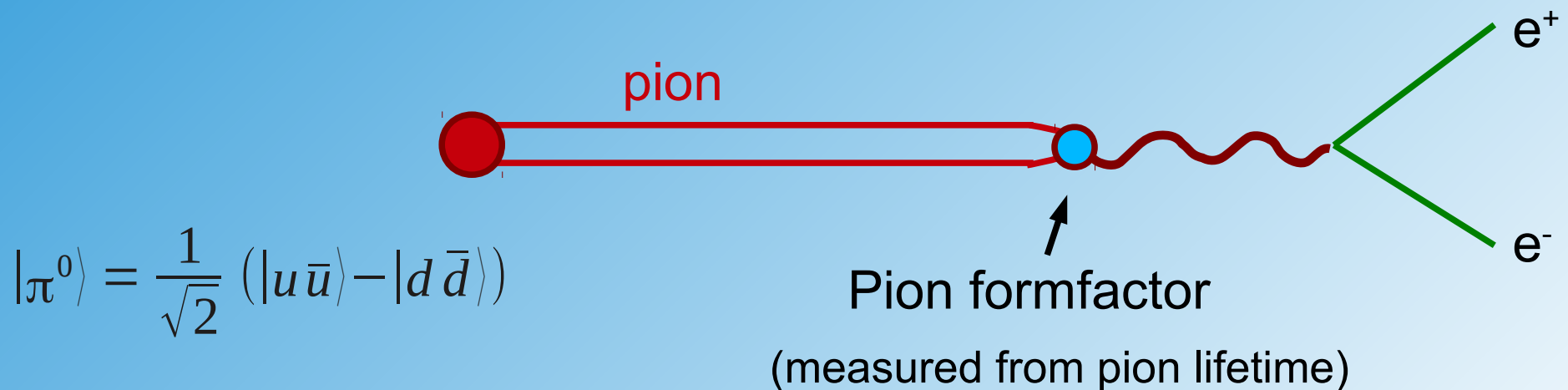

Test Pion Branching Ratios

- dominant decay: $B(\pi^0 \rightarrow \gamma\gamma) = 98.823 \%$
- radiative decay: $B(\pi^0 \rightarrow e^+e^- \gamma) = 1.174 \%$
- 2-prong decay: $B(\pi^0 \rightarrow e^+e^-) = 6.46 \times 10^{-8}$

Can QED describe this surprisingly small branching ratio?

Vector Currents: $j_{elm}^\mu = \bar{v}(x) \gamma^\mu u(x)$ per photon/fermion vertex

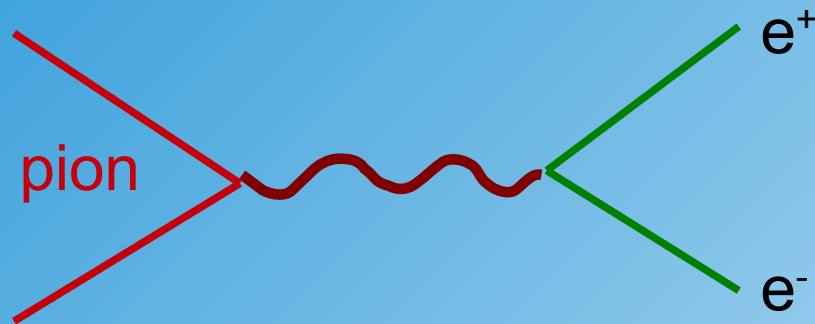

- Vector currents conserve helicity.
- Resulting spin should be $J(\pi^0)=1$
- But pion is a Pseudo-scalar $J(\pi^0)=0$
 → contradiction → helicity suppression

Polarisation of helicity state is given by fermion velocity:

$$\langle \lambda \rangle = \pm \beta \quad \text{for right/left chiralities}$$

Resulting suppression factor:

$$\frac{1}{16} (1 - \beta_q^2)(1 - \beta_e^2) = \frac{1}{16 \gamma_q^2 \gamma_e^2} = \frac{m_q^2 m_e^2}{m_\pi^4}$$

no scalar couplings!

$$\sim 3 \cdot 10^{-8}$$

QED Radiative Effects

- **Bremsstrahlung**
- **Higher Order Processes**

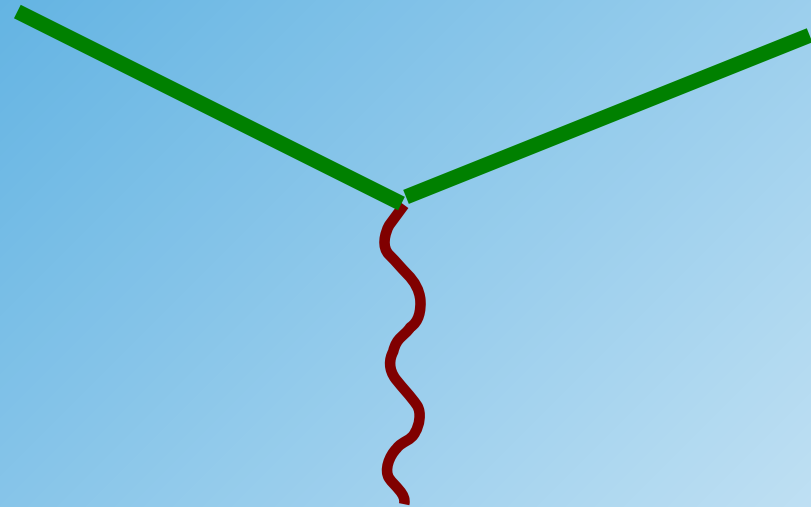

Experimentally very important:

- can be exploited for measurements (luminosity, radiative returns)
- but can also disturb measurements!

QED First Order Corrections

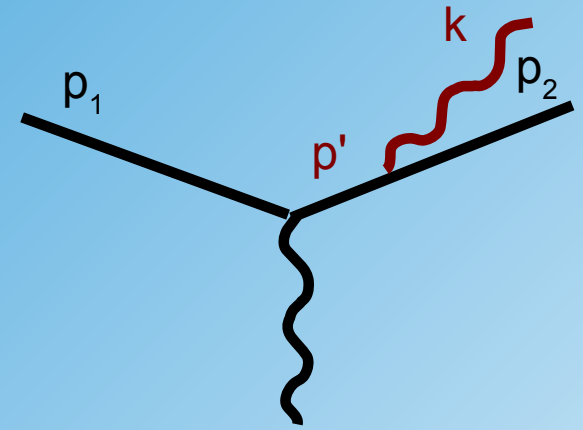
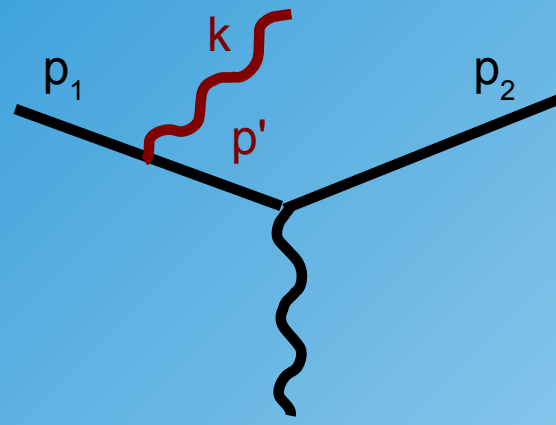
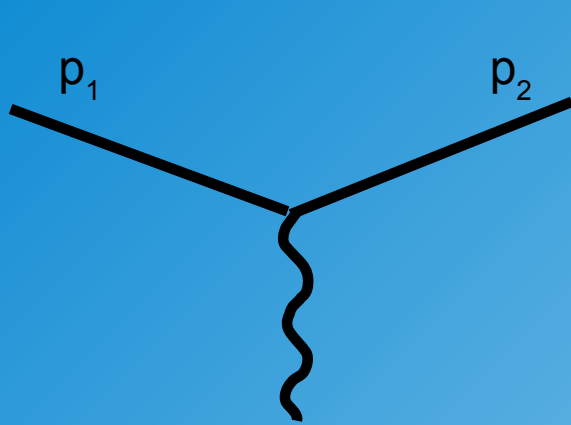

initial state radiation (ISR)

final state radiation (FSR)

Fermion propagator:

$$\frac{1}{p'^2 - m^2} = \frac{1}{(p_1 - k)^2 - m^2}$$

$$\frac{1}{p'^2 - m^2} = \frac{1}{(p_2 + k)^2 - m^2}$$

ISR:

$$\frac{1}{(p_1 - k)^2 - m^2} = \frac{1}{p_1^2 + k^2 - 2p_1 k - m^2} = \frac{1}{-2p_1 k} \approx \frac{1}{-2E_e E_\gamma (1 - \cos \theta)} \quad (\text{if mass small})$$

Singularities:

- photon emission under zero degrees $\theta \rightarrow 0$
- soft photon $E_\gamma \rightarrow 0$

FSR: similar

ISR + FSR: interference term shows no singularity (wide angle scattering)

QED First Order Corrections

- Singularities are not allowed in (renormalisable) gauge theories and have to cancel
- Singularity from “soft” and collinear Bremsstrahlung cancel with virtual vertex corrections in QED

“real corrections” (Bremsstrahlung)

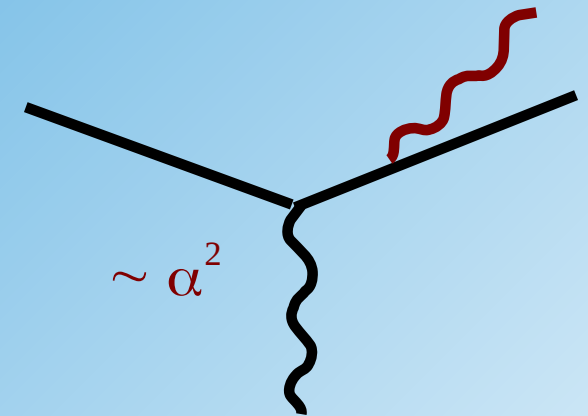
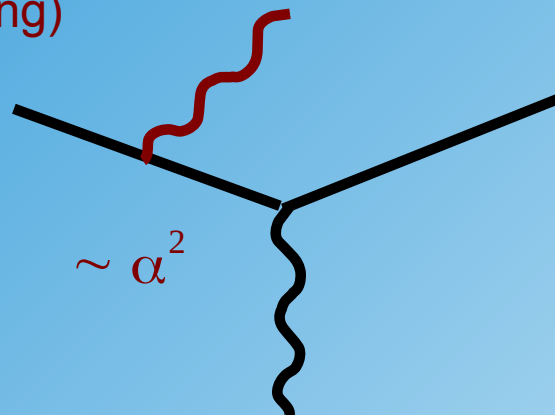

virtual correction:

interference of LO diagram
and vertex correction $\sim \alpha^2$
compensates singularities
from Bremsstrahlung

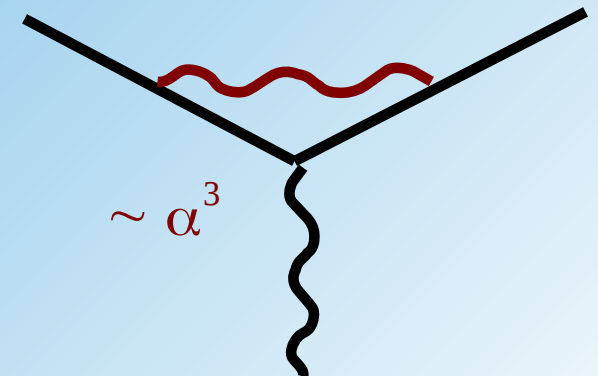
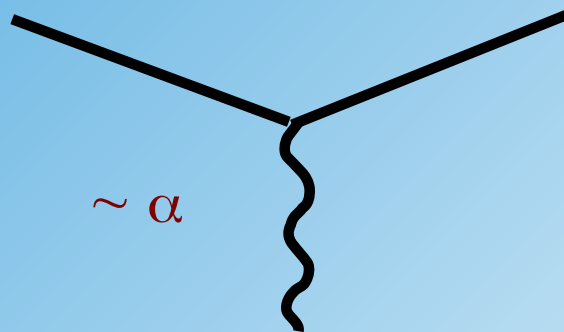

Electron-Proton Collider HERA

$$E_e = 26.7 \text{ GeV} \quad E_p = 920 \text{ GeV}$$



Proton Parton Densities

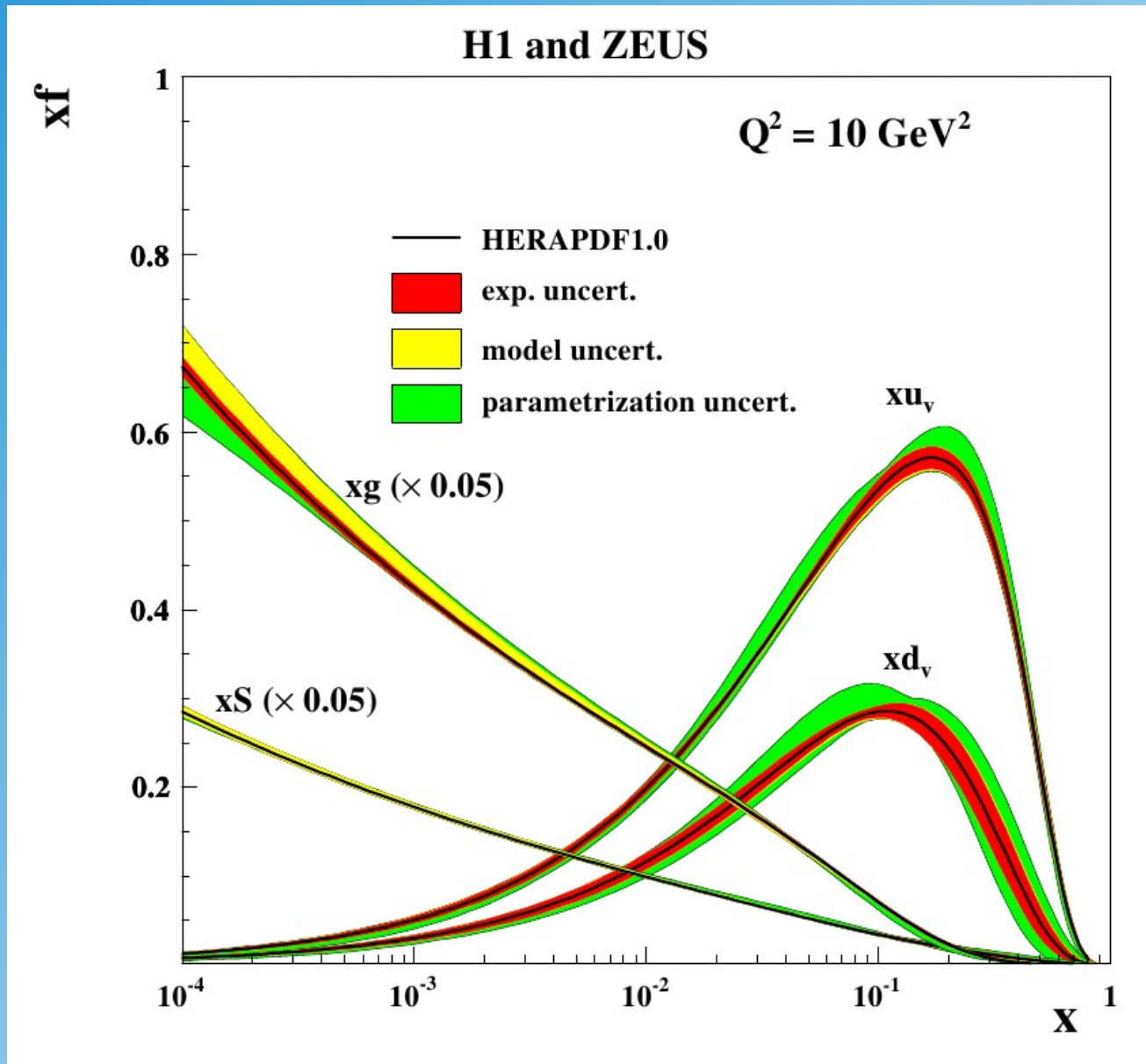

$$Q^2 = 25030 \text{ GeV}^2, \quad y = 0.56, \quad M = 211 \text{ GeV}$$

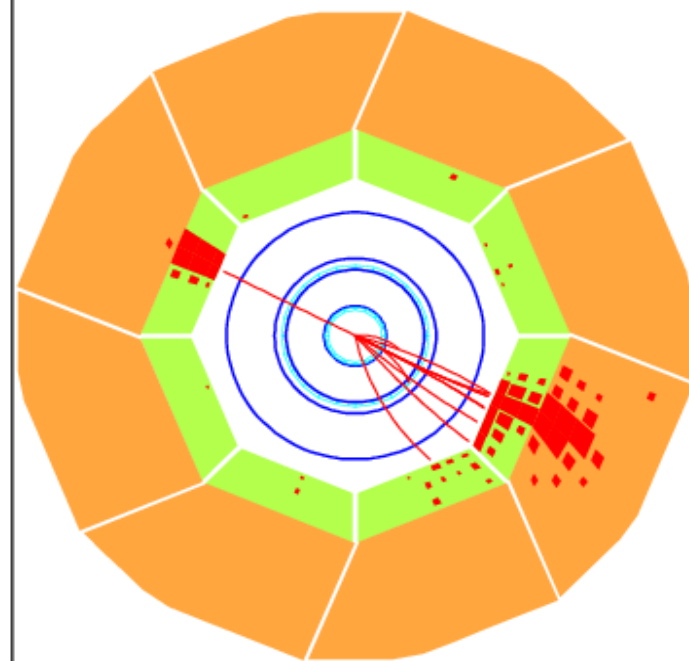
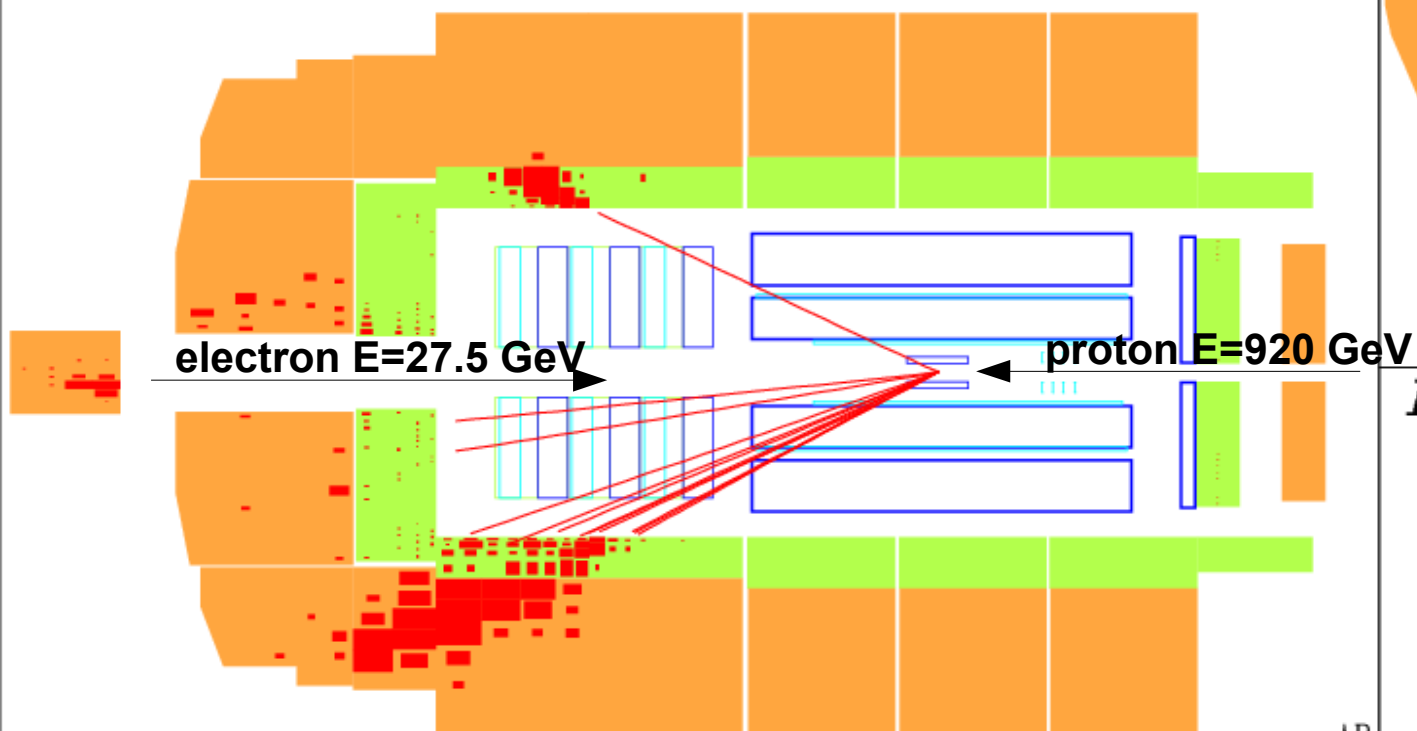

$ep \rightarrow e X$ (neutral current)

E_t/GeV

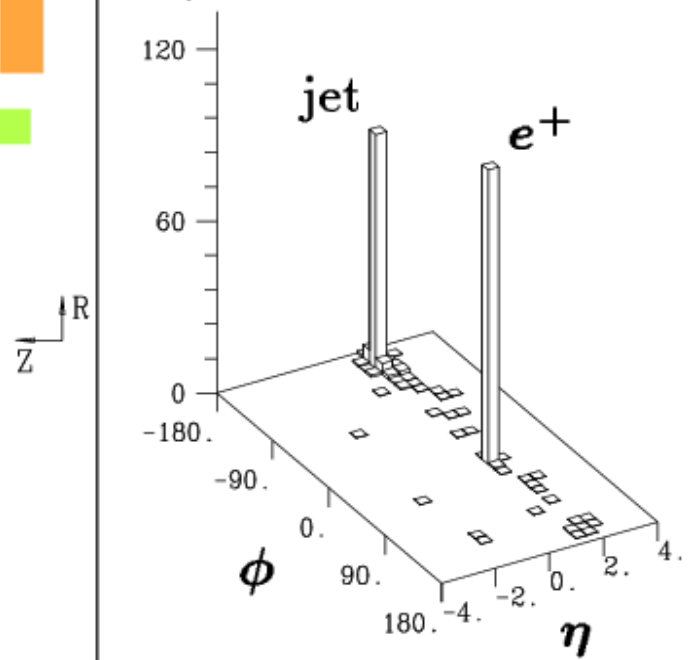

Kinematics Scattering Process

The virtuality of the exchanged photon is given by:

$$Q^2 = -q^2 = -(p - p')^2$$
$$\propto \frac{1}{\sin^4 \theta / 2}$$

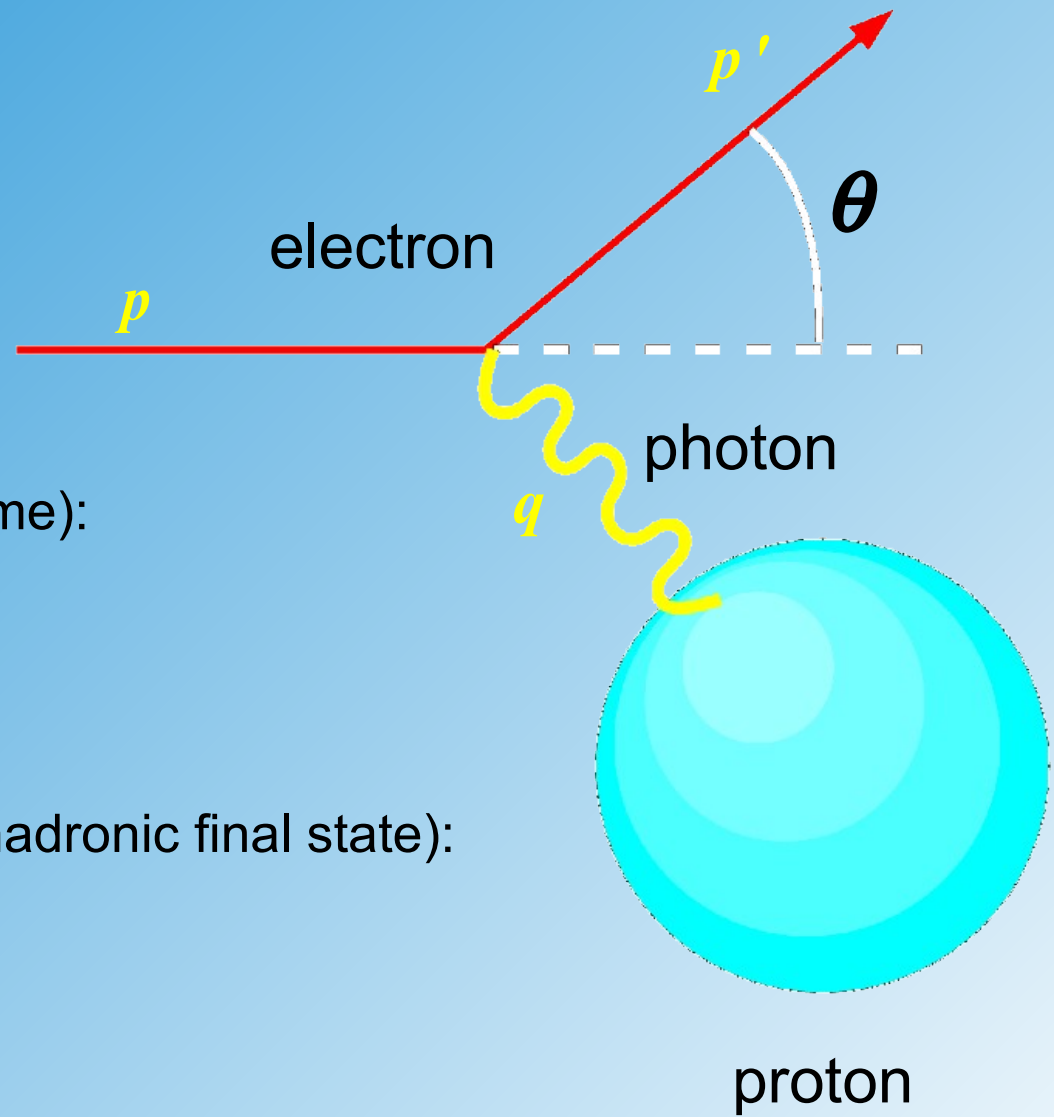

Energy transfer (in Proton-rest frame):

$$\nu = E_{Elektron} - E_{Elektron}'$$

Energy of photon-proton system (hadronic final state):

$$W = m_p + \nu$$

Lorentz Invariant Kinematics of Deep Inelastic Scattering Process

The virtuality of the exchanged photon is given by:

$$Q^2 = -q^2 = -(p - p')^2$$

$$\propto \frac{1}{\sin^4 \theta / 2}$$

Relative energy loss (inelasticity):

$$y = \frac{\nu}{E_{\text{Elektron}}} = \frac{q P}{p P}$$

relative fraction of parton momentum:

$$x = \frac{q^2}{2 q P} = \frac{Q^2}{s y}$$

with cms energy: $s = 2 p P$

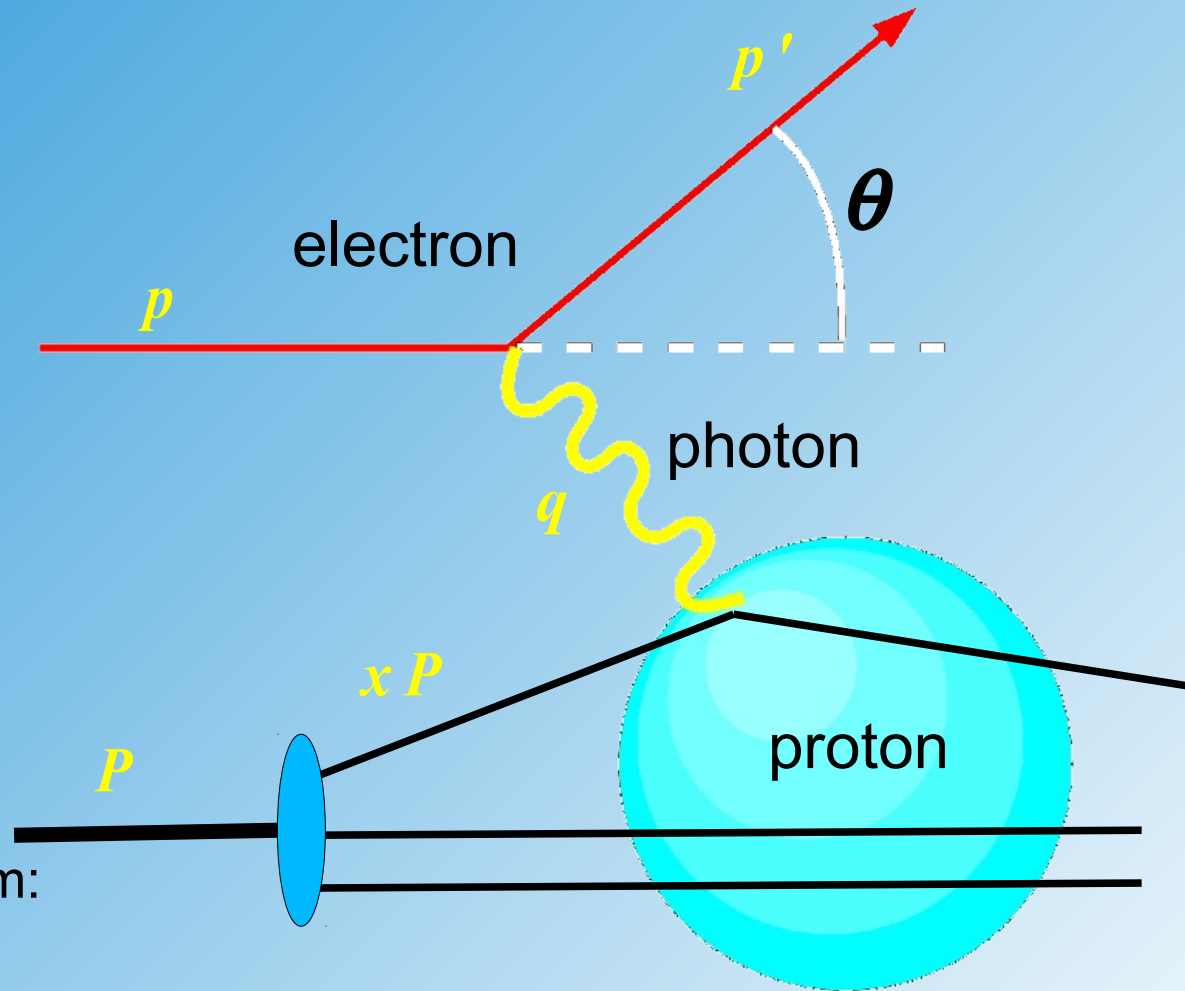

$$Q^2 = 25030 \text{ GeV}^2, \quad y = 0.56, \quad M = 211 \text{ GeV}$$

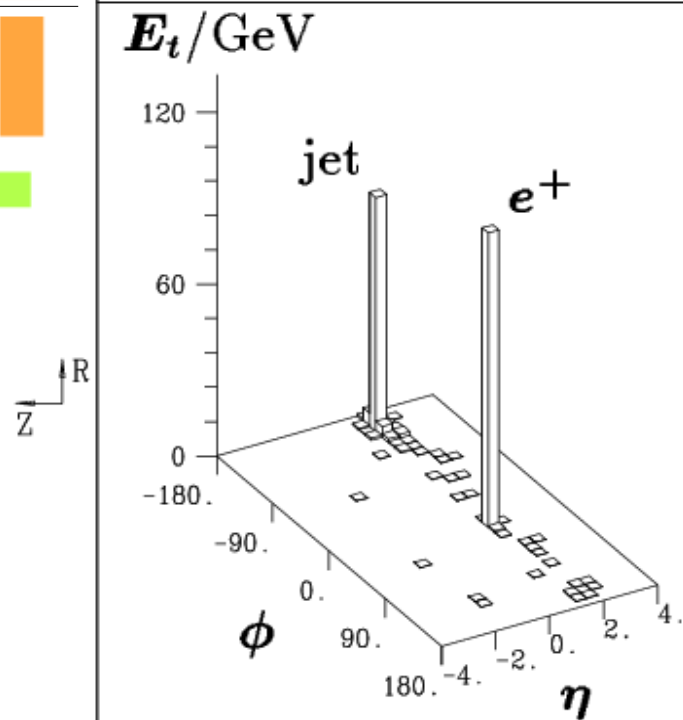
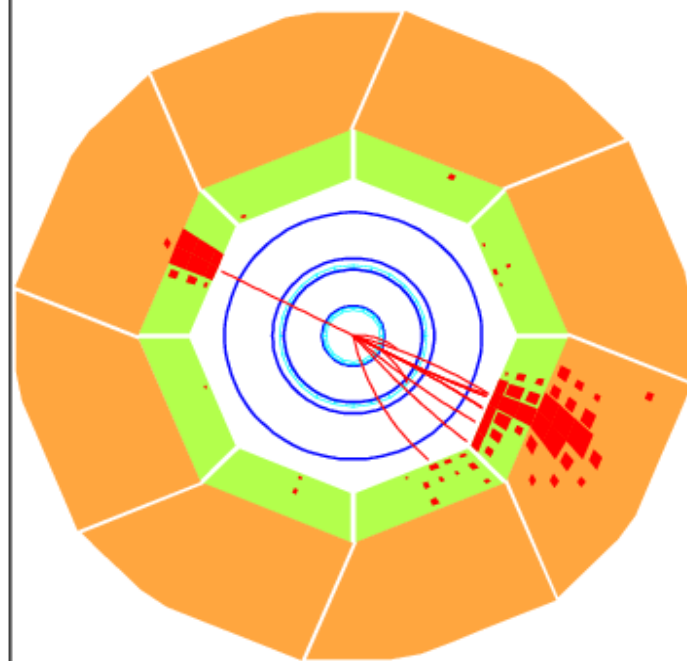
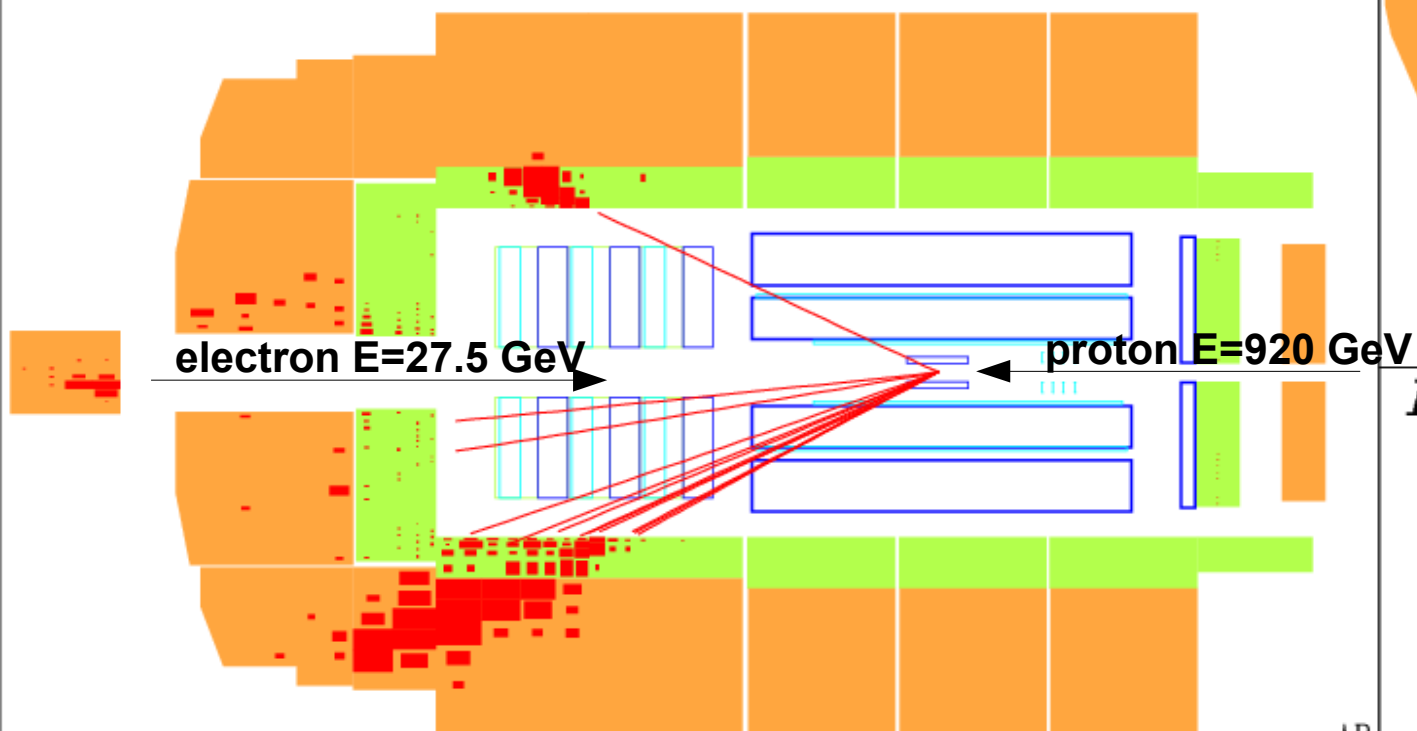

Determination of Luminosity?

Reference Process

Need process with large cross section

- Bethe Heitler Process: $e p \rightarrow ep \gamma$
- Bremsstrahlung-Process with large cross section (~ 1 barn)!

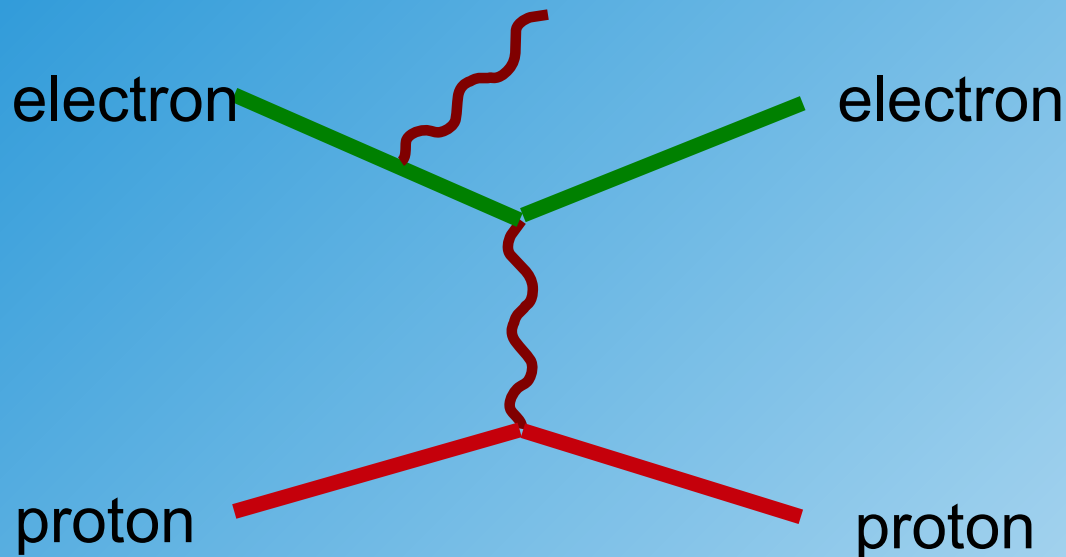

Note,

- the proton stays intact (elastic)!
- the cross section can only be given for a minimum photon energy!
(infrared singularity)

Radiative Effects in Electron-Proton Scattering

Bremsstrahlung proportional to $\frac{1}{(p-k)^2 - m^2}$

Bremsstrahlung effects are large for particles with low mass

Electron mass: $m_e = 0.511 \text{ MeV}$ \longrightarrow **heavy radiation!**

Proton mass: $m_p = 938 \text{ GeV}$

Radiation is large if

1. photon is **soft**
2. photon is emitted **collinear**

Photons can be emitted from

1. incoming electron (initial state radiation, **ISR**)
2. outgoing electron (final state radiation, **FSR**)

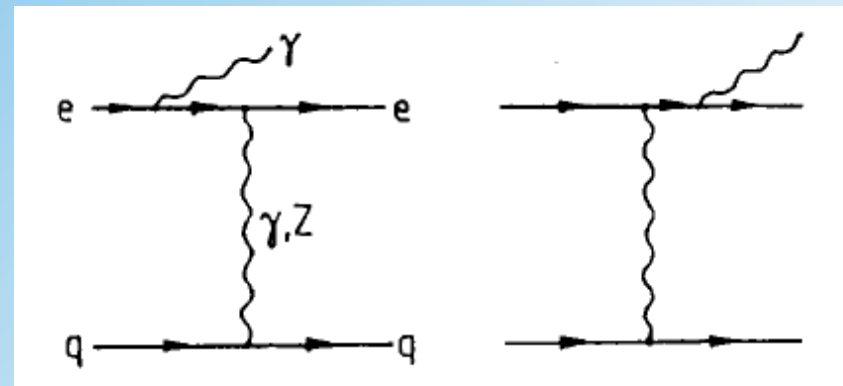

Radiative Poles

Neglecting the small electron mass, the poles become:

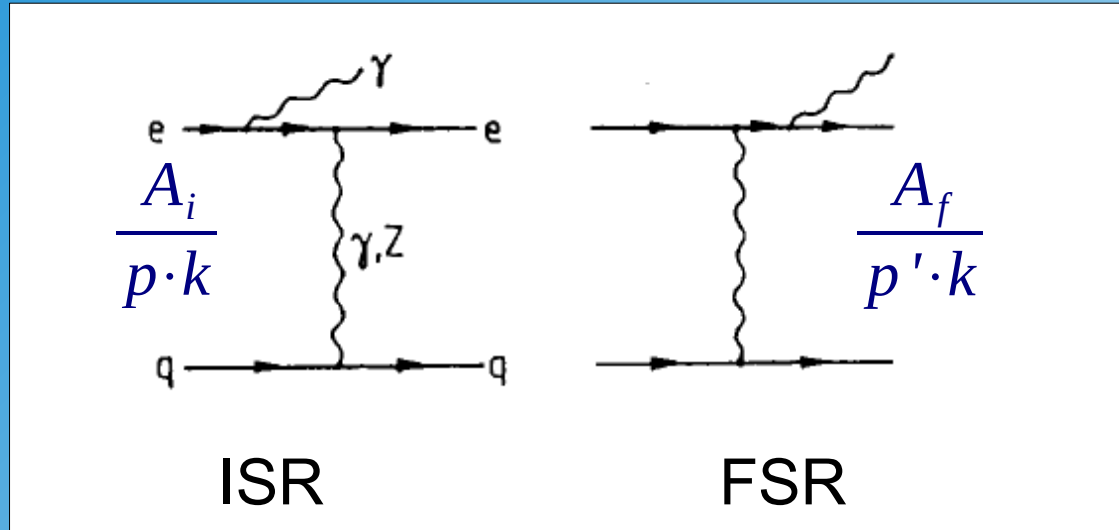

Note ISR reduces the available center of mass energy $s^{1/2}$

$$E_e = 26,7 \text{ GeV}$$

$$E_p = 820 \text{ GeV}$$

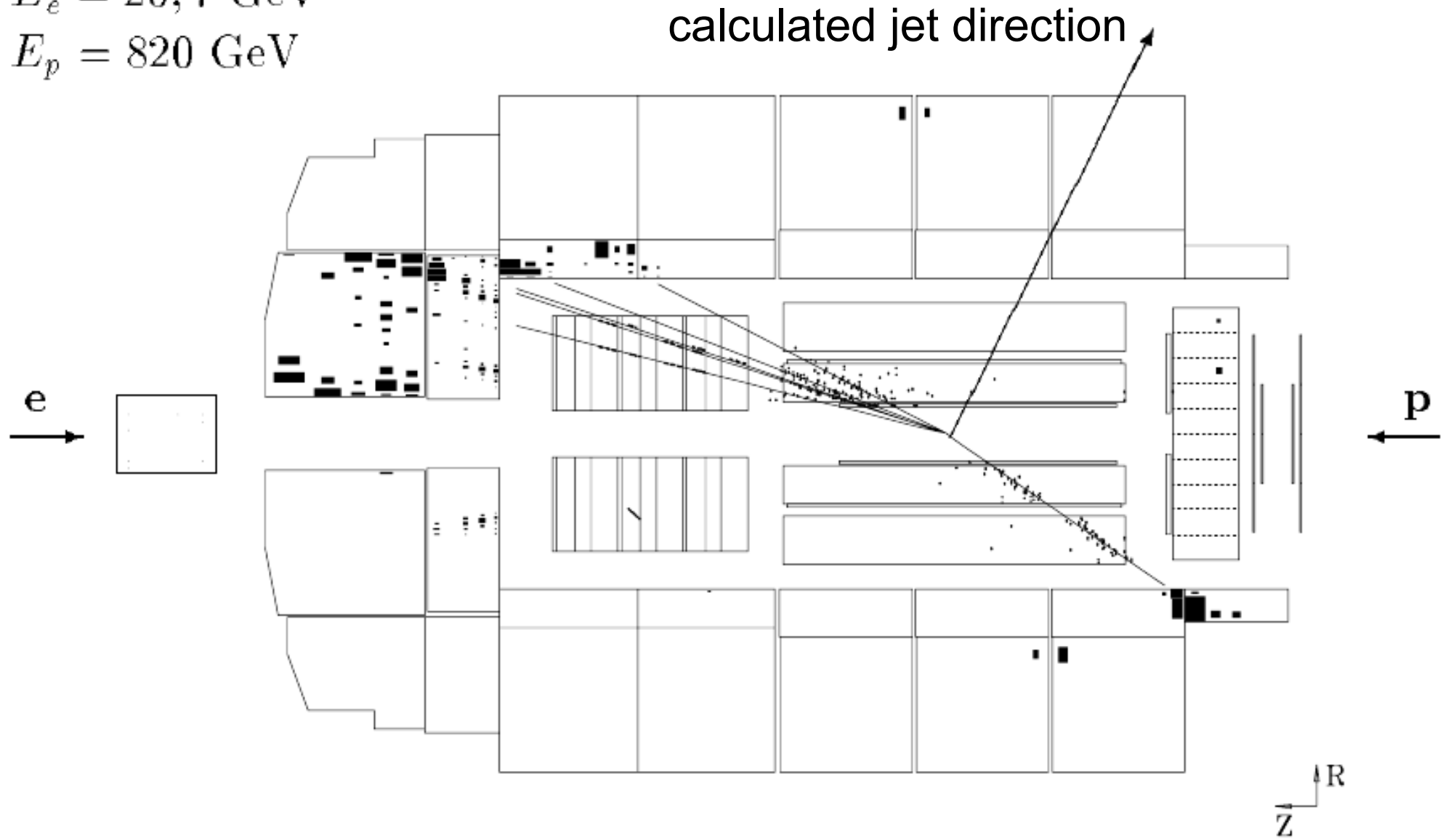

Initial State Radiation?

$$E_e = 26,7 \text{ GeV}$$

$$E_p = 820 \text{ GeV}$$

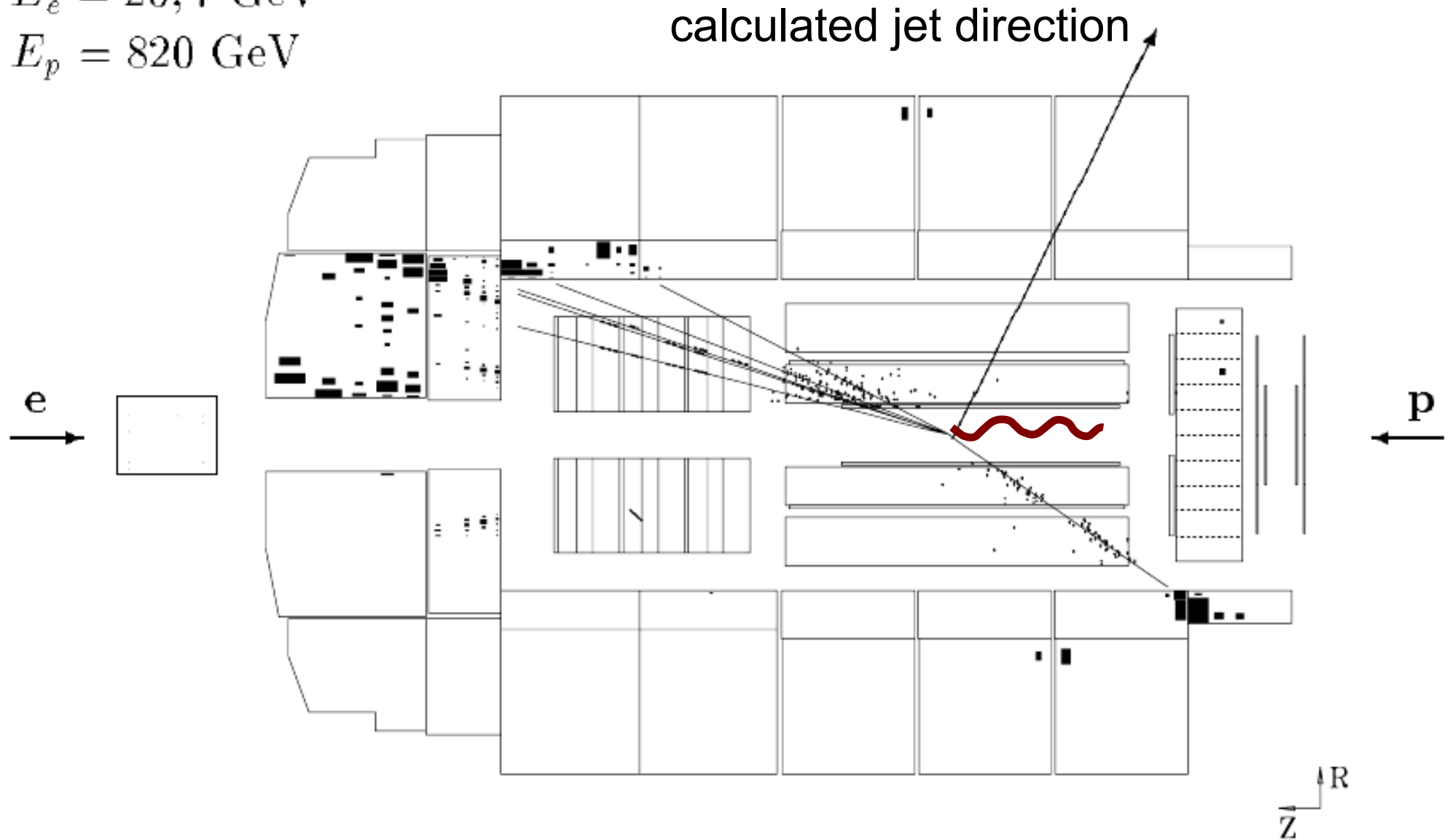

Energy E conserved and momentum p conserved $E-p_z$ conserved

$$E-p_z (\text{proton})=0$$

$$E-p_z (\text{electron}) = 2 \times 26.7 \text{ GeV}$$

Kinematic Reconstruction of ISR

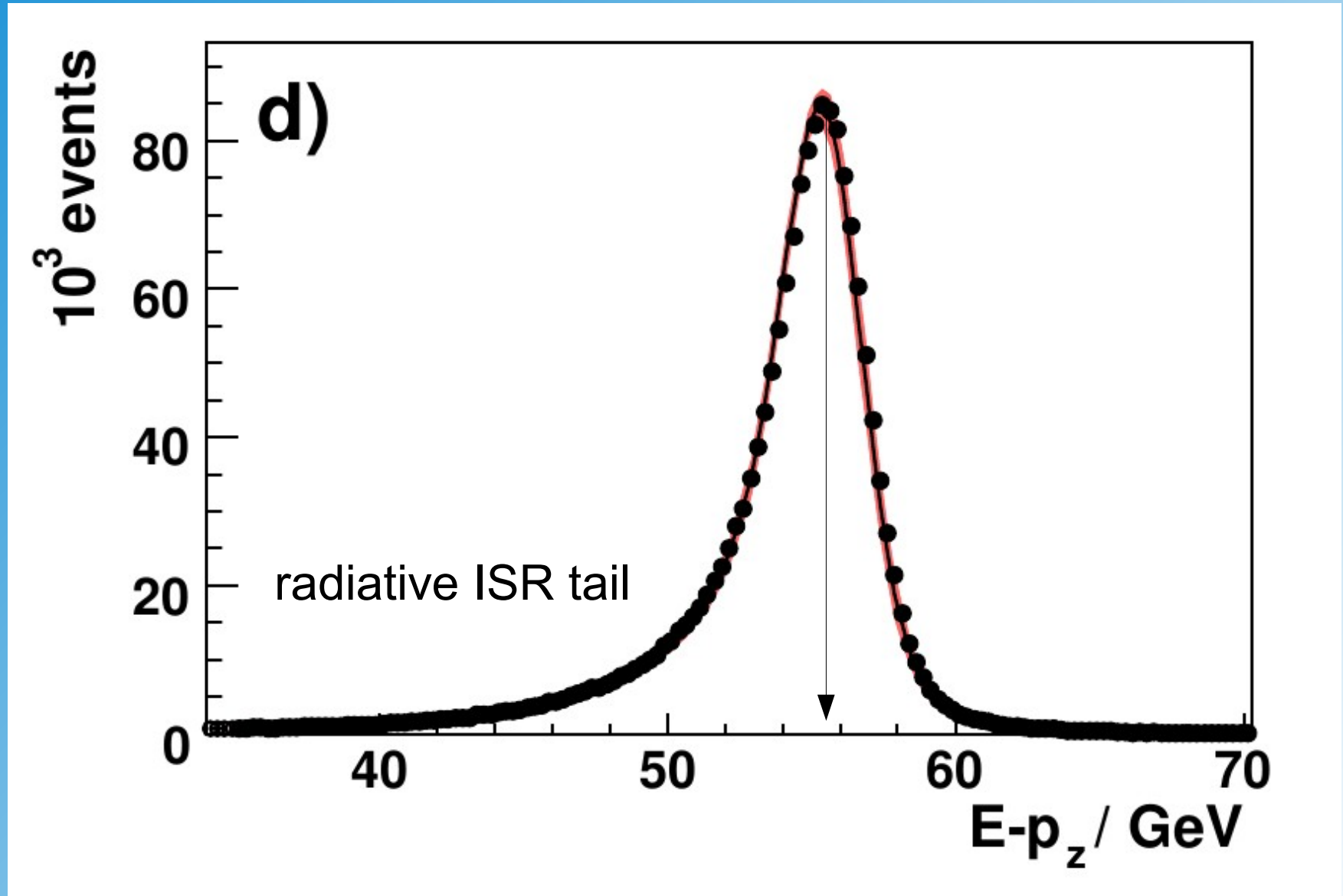

Photondetector at H1

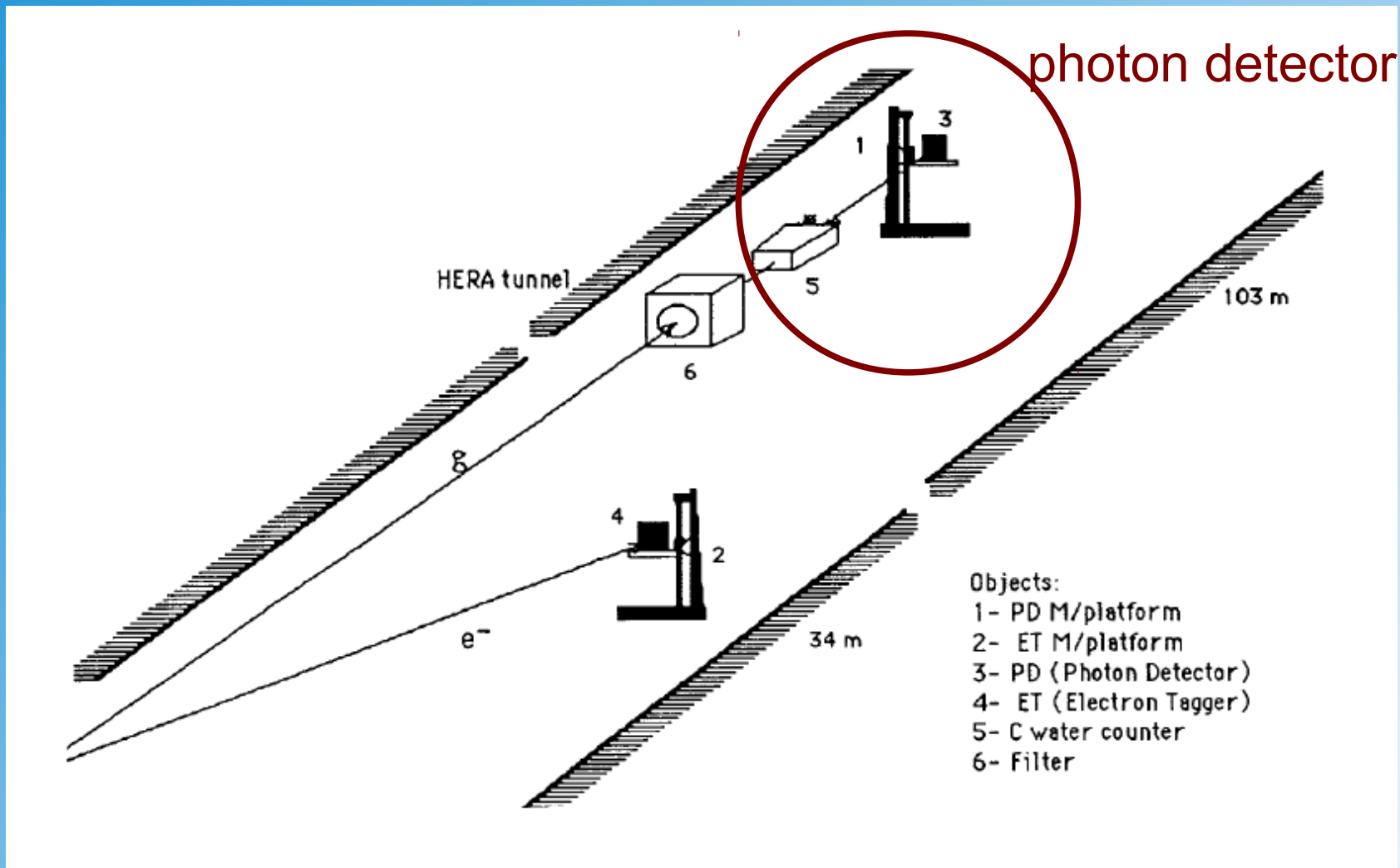

$E_e = 26,7 \text{ GeV}$

$E_p = 820 \text{ GeV}$

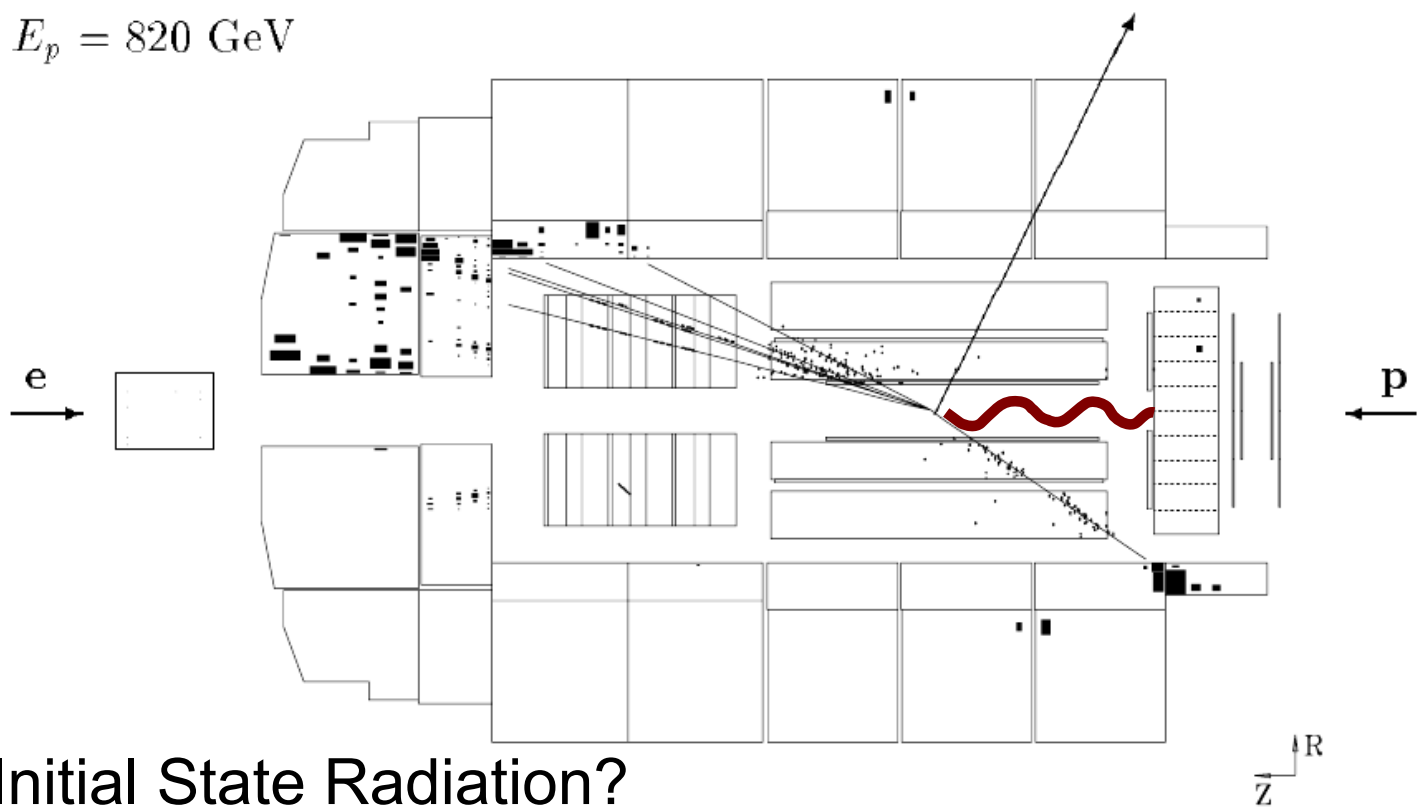

Initial State Radiation?

PD $E_{dep} = 8.5 \text{ GeV}$
 $E_{trig} = 5.1 \text{ GeV}$

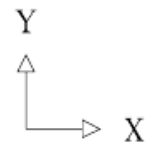
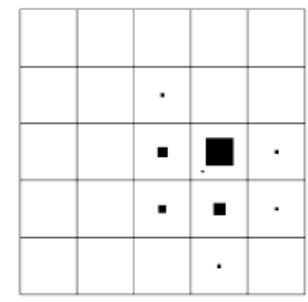

NC - DIS with hard Photon

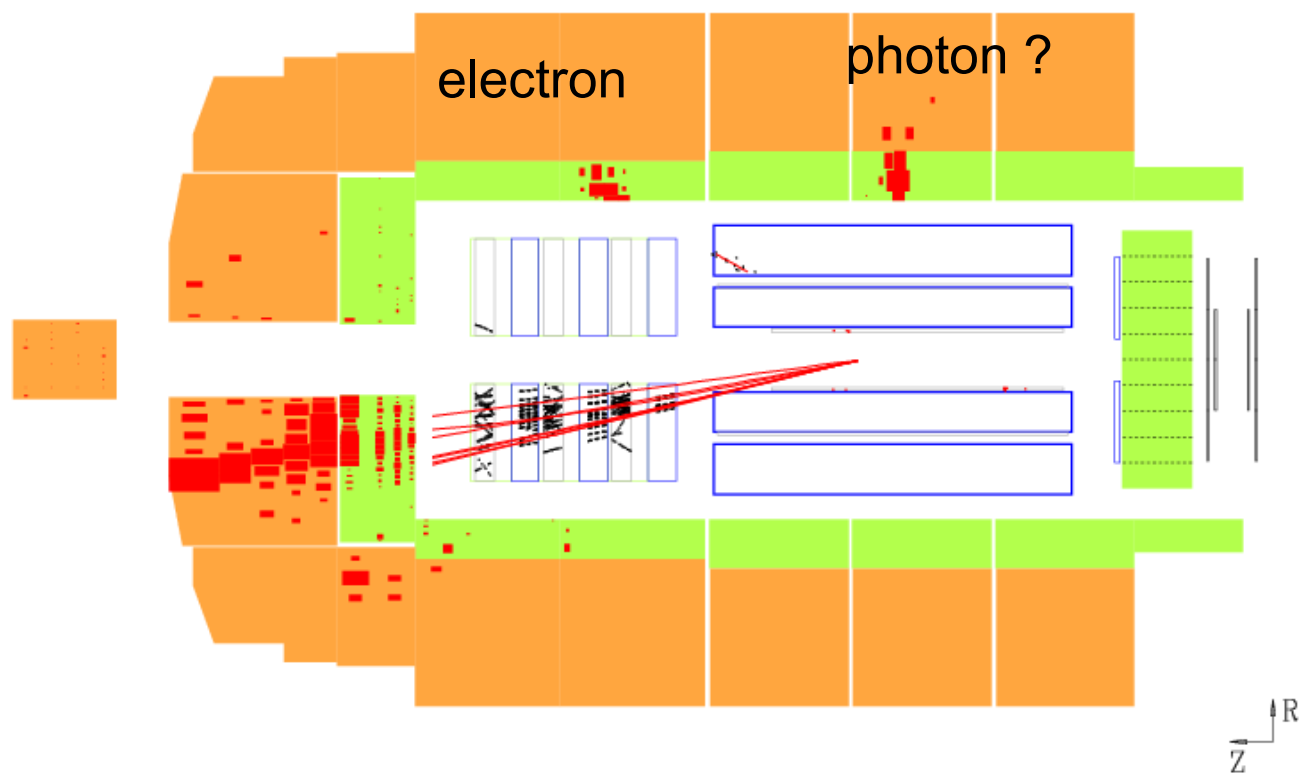

Inner Drift Chamber operational?

Final State Radiation?

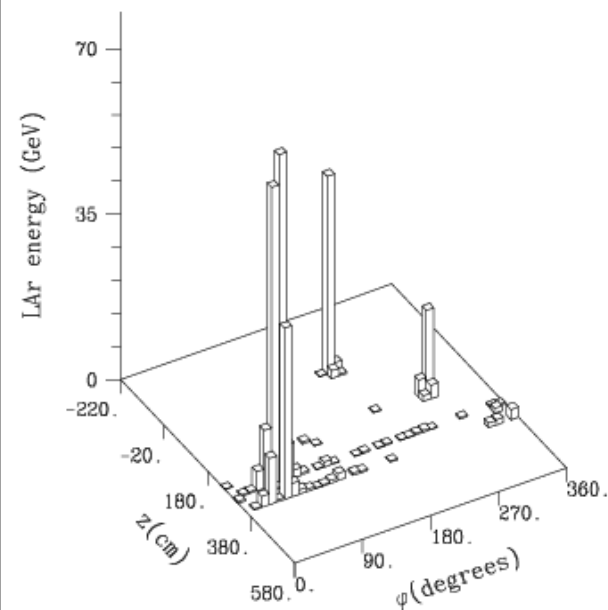
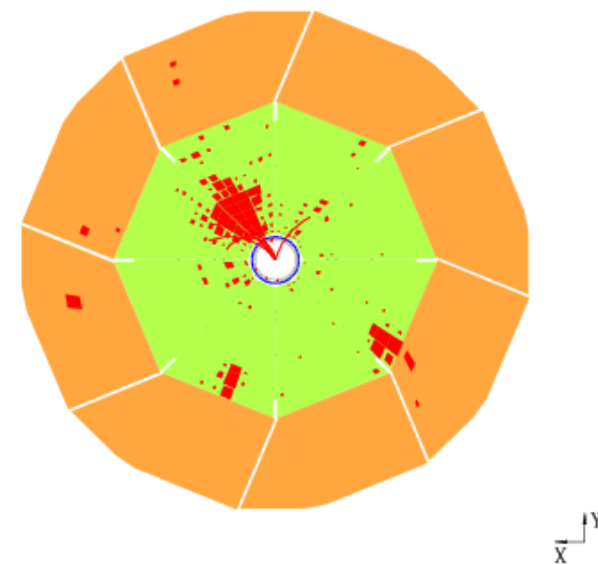

NC - DIS with hard Photon

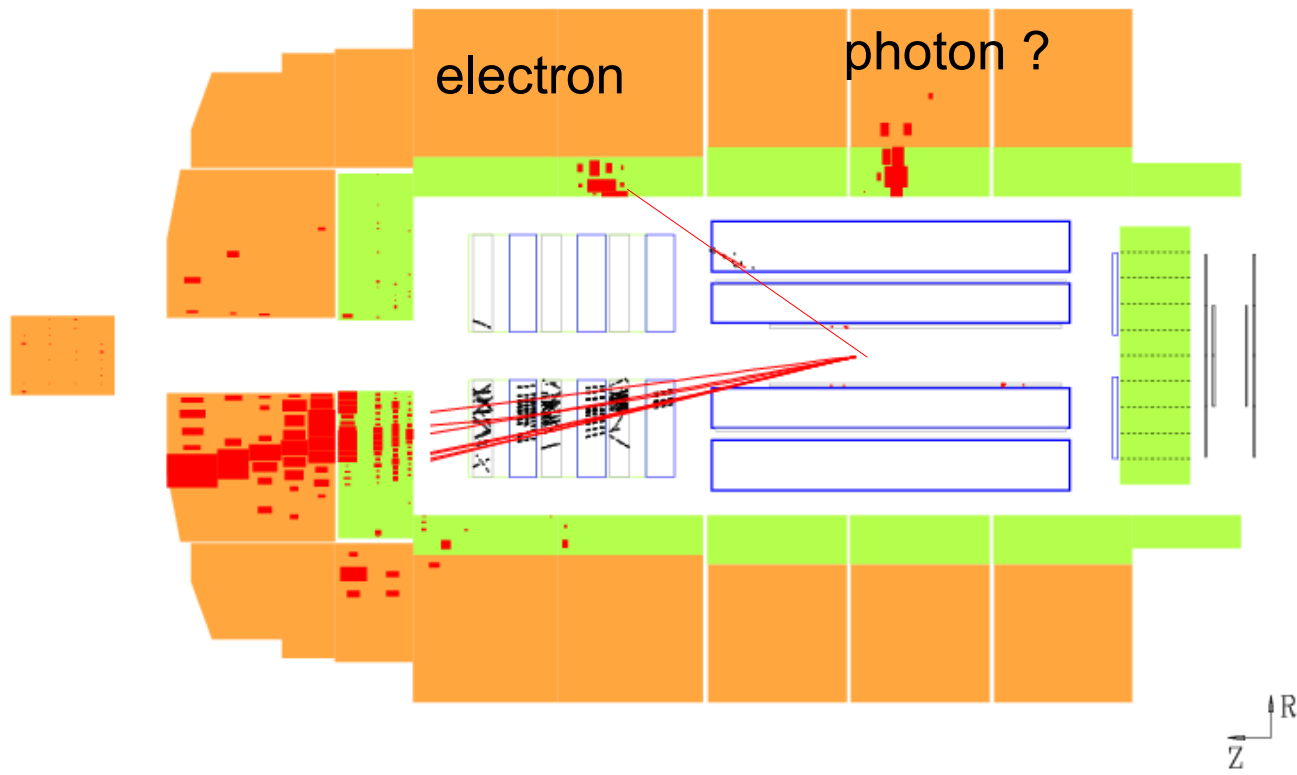

Inner Drift Chamber operational?

Final State Radiation?

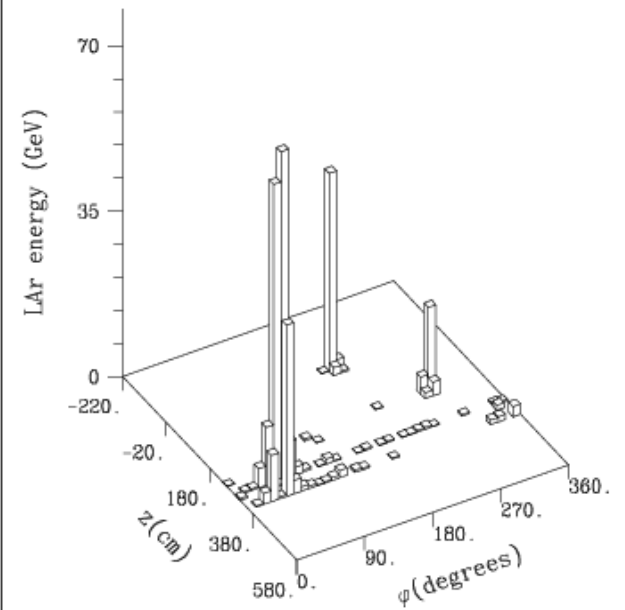
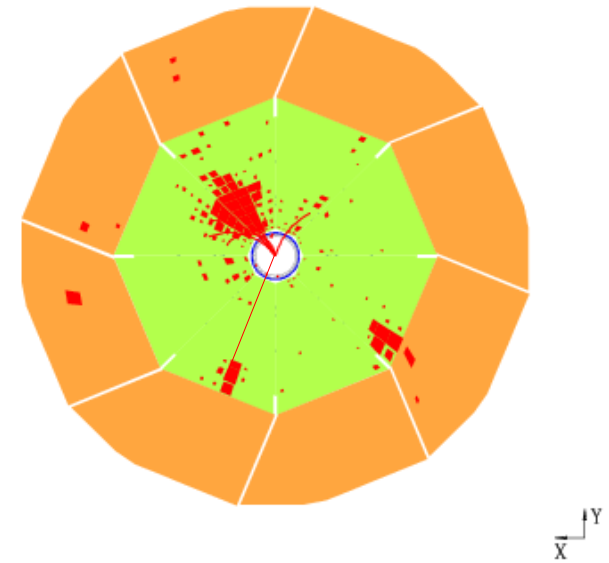

$$Q^2 = 25030 \text{ GeV}^2, \quad y = 0.56, \quad M = 211 \text{ GeV}$$

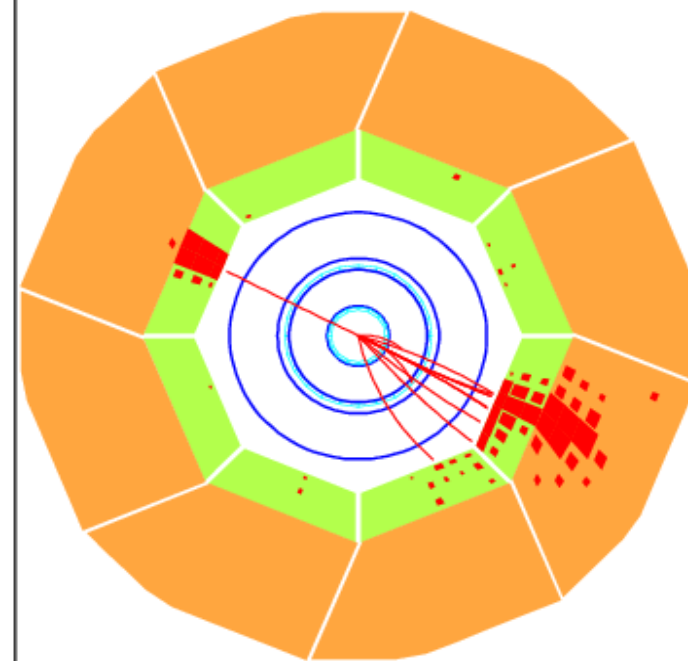
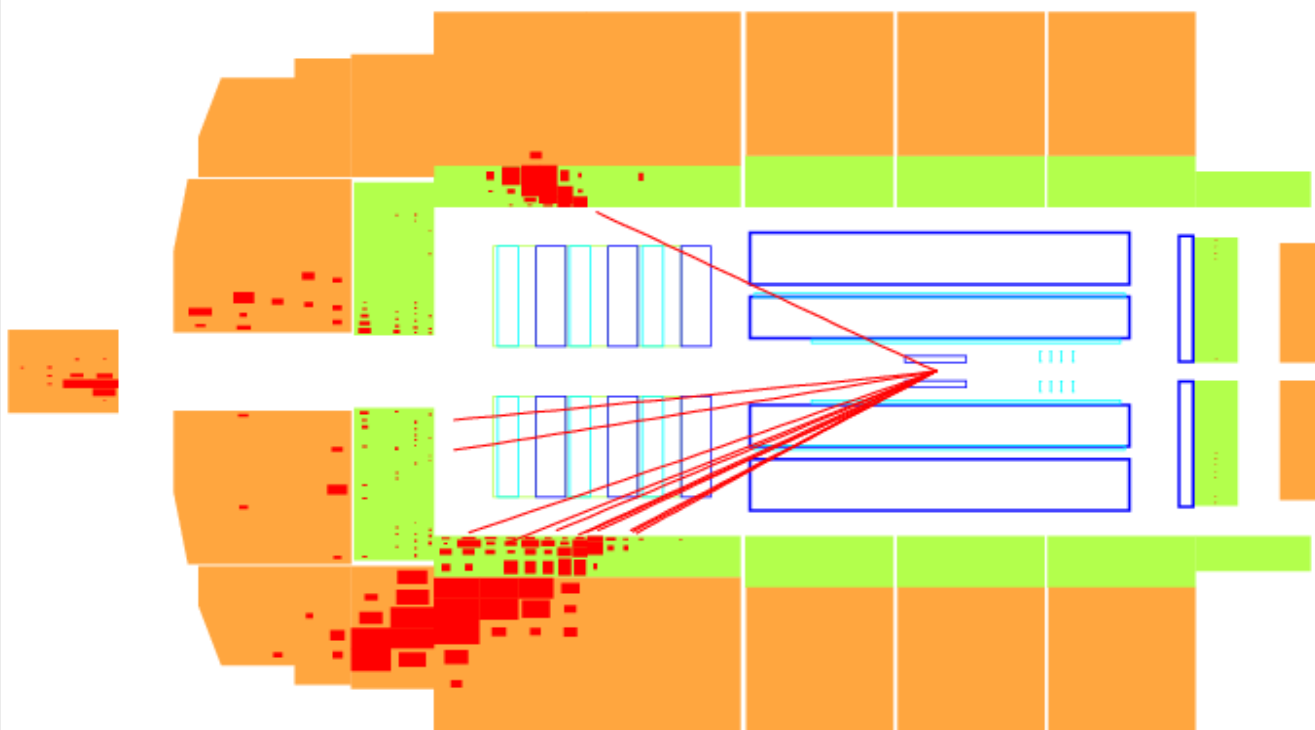

Question: Final State Radiation?

collinear photon can not be resolved!

E_t/GeV

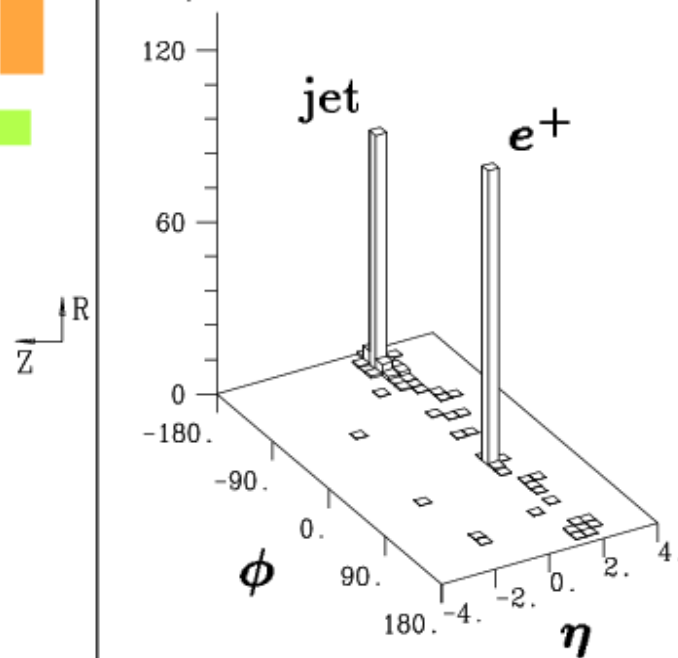

Radiative Poles

Neglecting the small electron mass, the poles become:

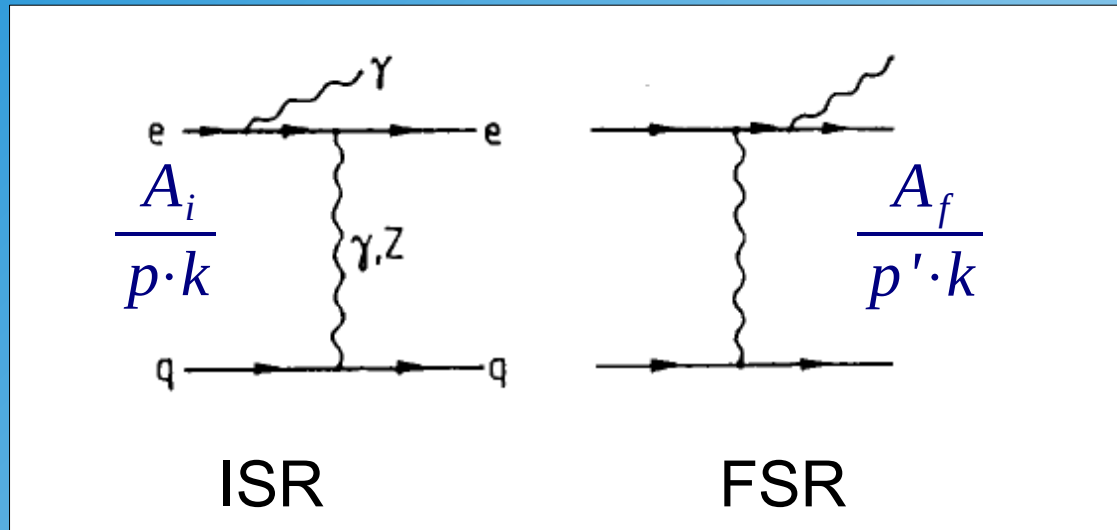

Note ISR reduces the available center of mass energy $s^{1/2}$

- There is a third pole (Compton events / Wide Angle Bremsstrahlung):

$$\frac{A_c}{(p - p' - k)^2} = \frac{1}{q^2} \quad (\text{energy is transferred from the proton to the electron line})$$

Final state electron and photon have large opening angles and are p_T balanced

QED Compton

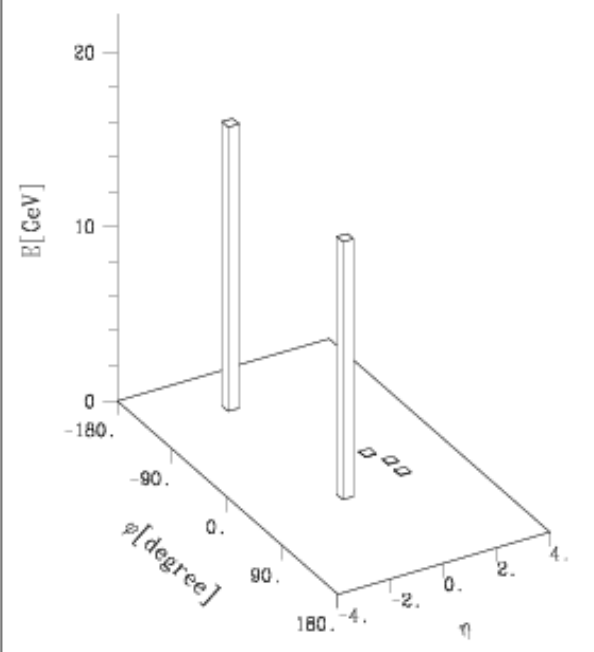
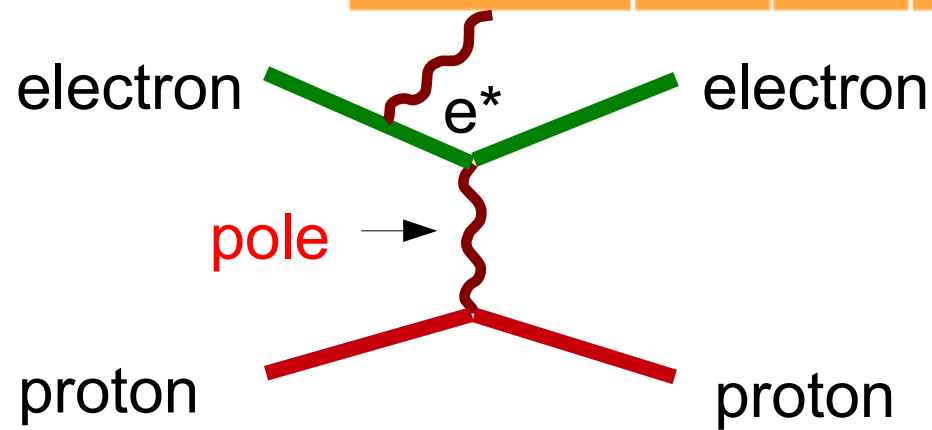
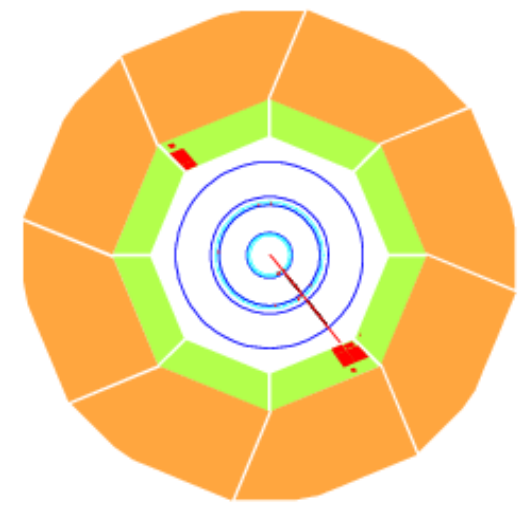
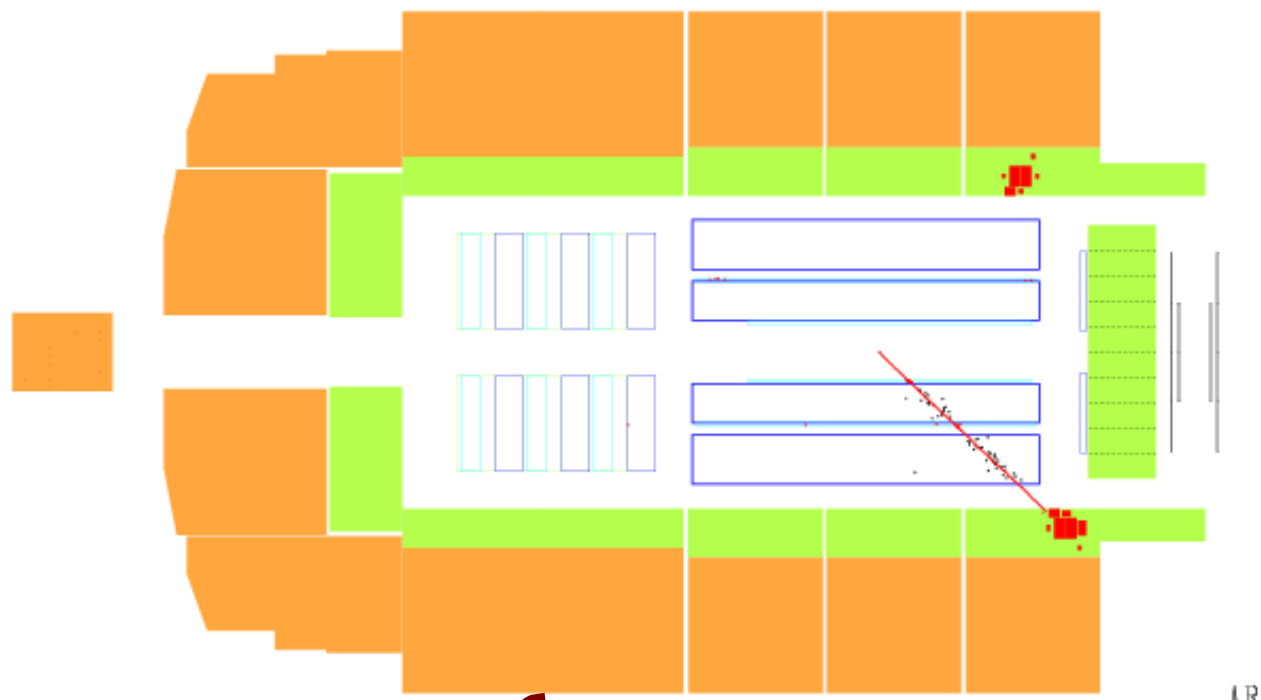

Bethe Heitler Process

diagram:

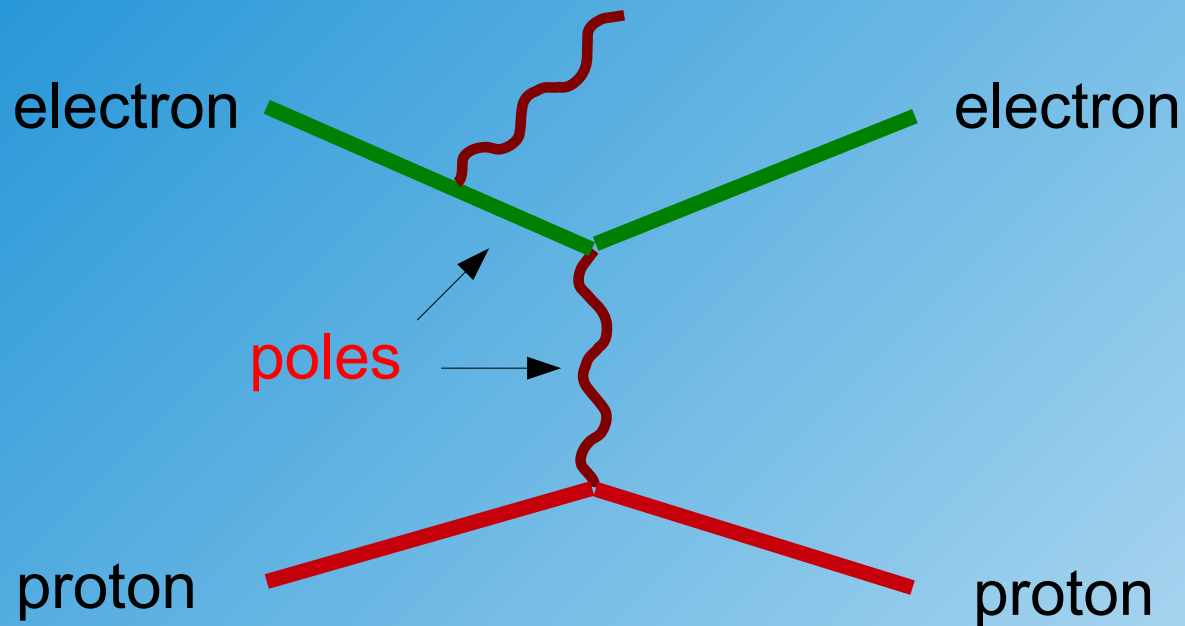

Cross section is largest if electron and photon are scattered (emitted) at small angle (Compton and ISR/FSR poles combined)

Electron and photon go down the beampipe and are not registered in the central detector

Luminosity Measurement at HERA

dedicated electron and photon detectors

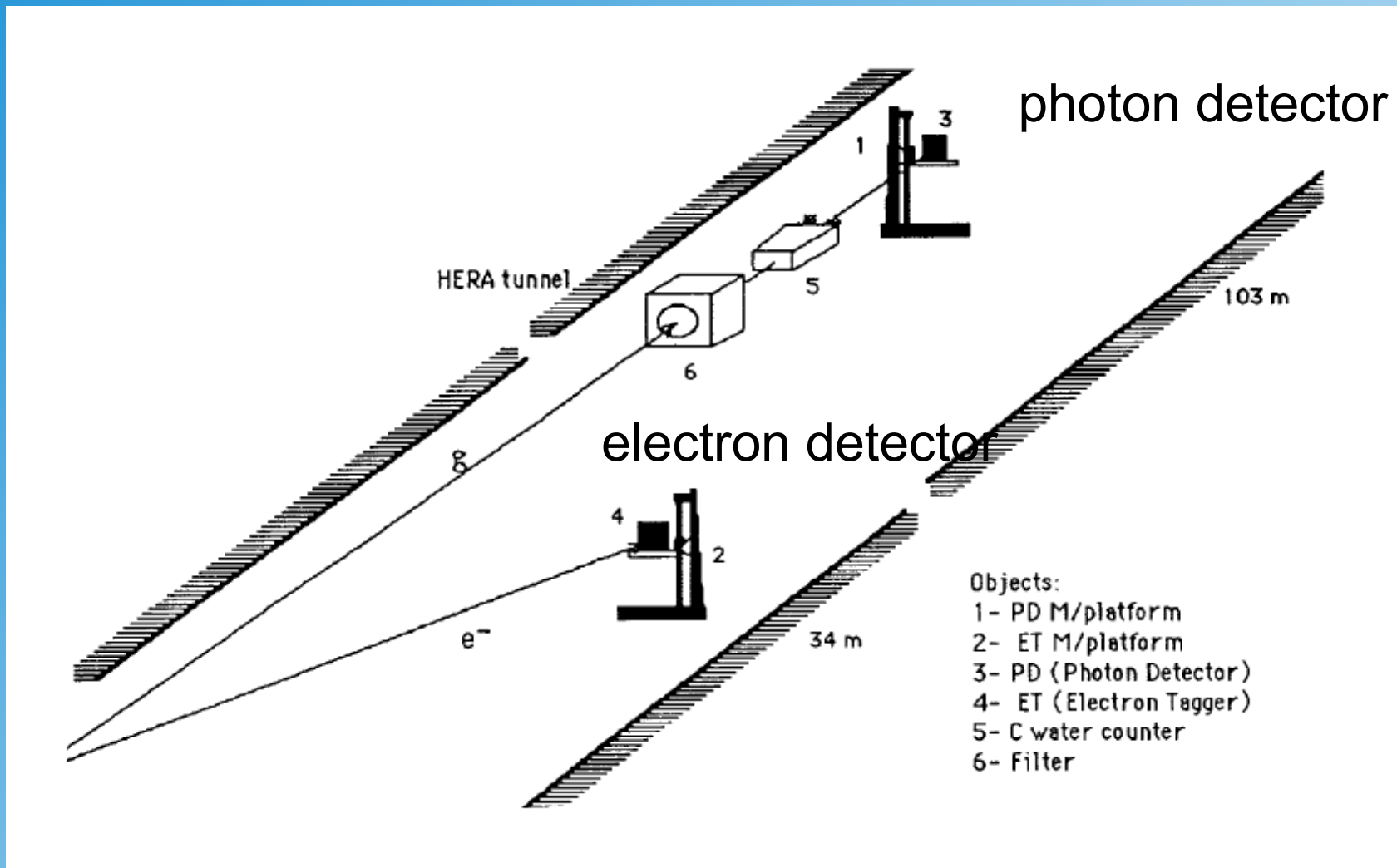

H1 Luminosity Detectors

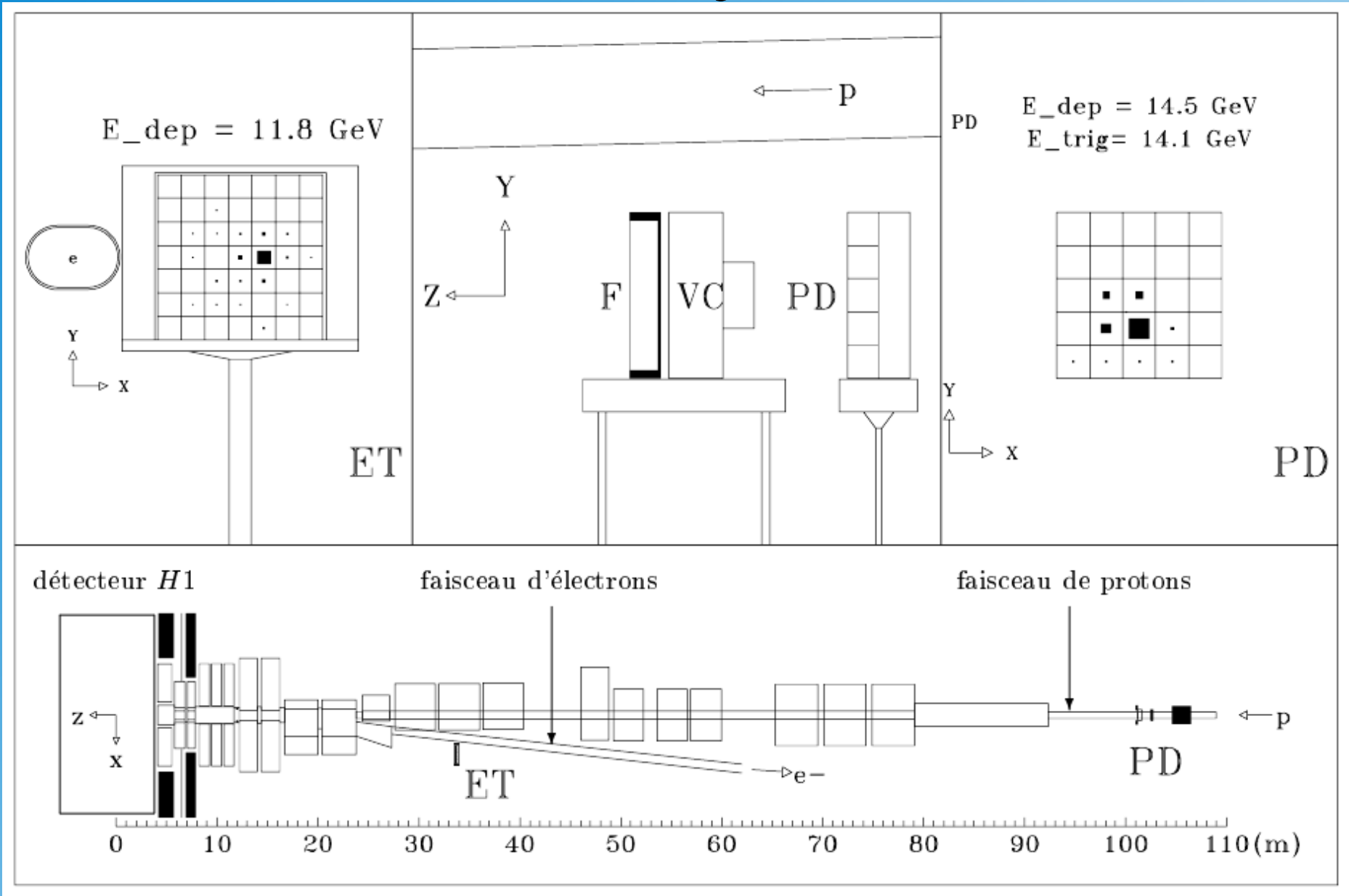

Method: measure coincidence signal

Coincidence Technique

Photon Energy

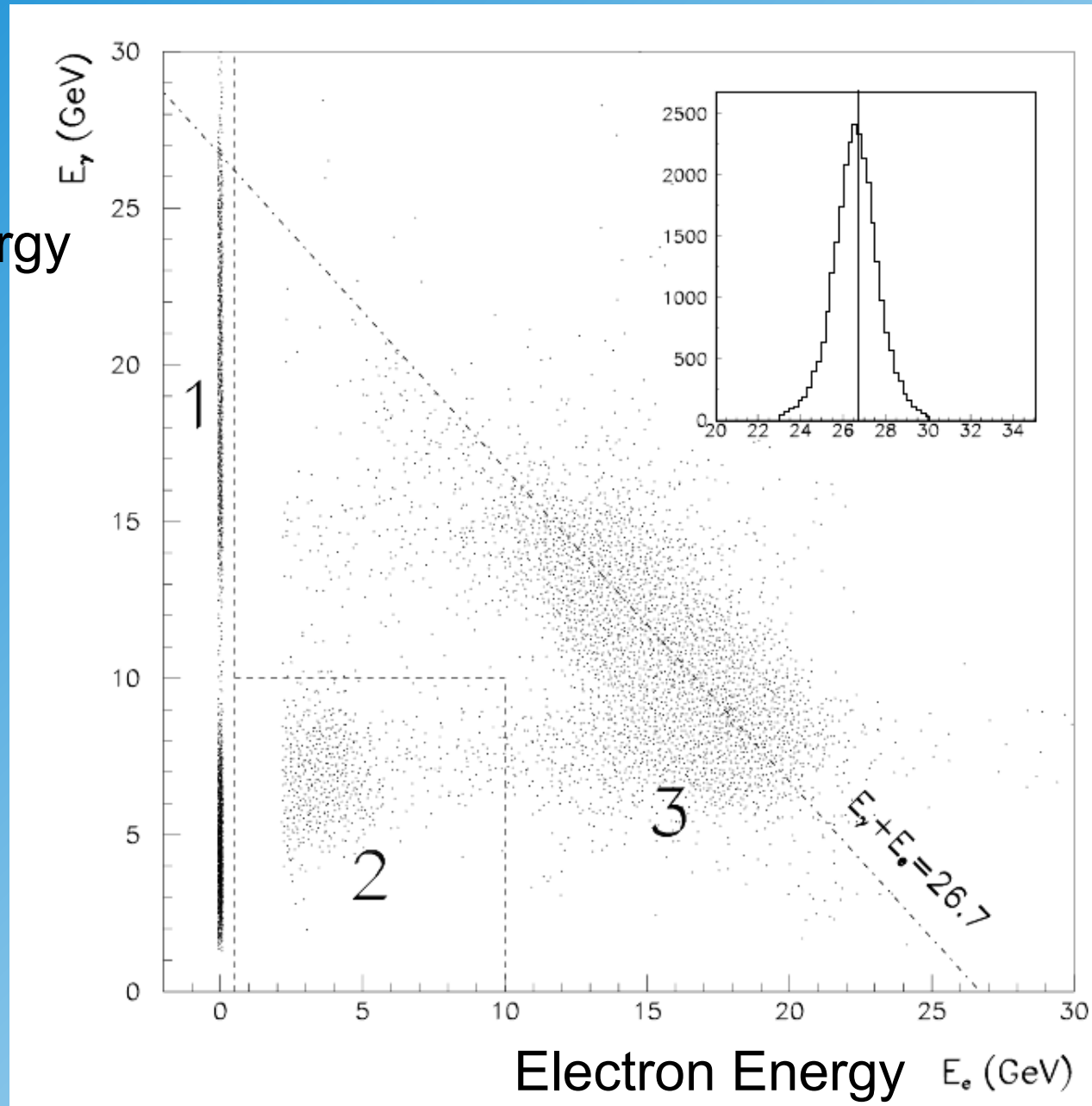

Data Monte Carlo Comparison

Photon Detector Energy

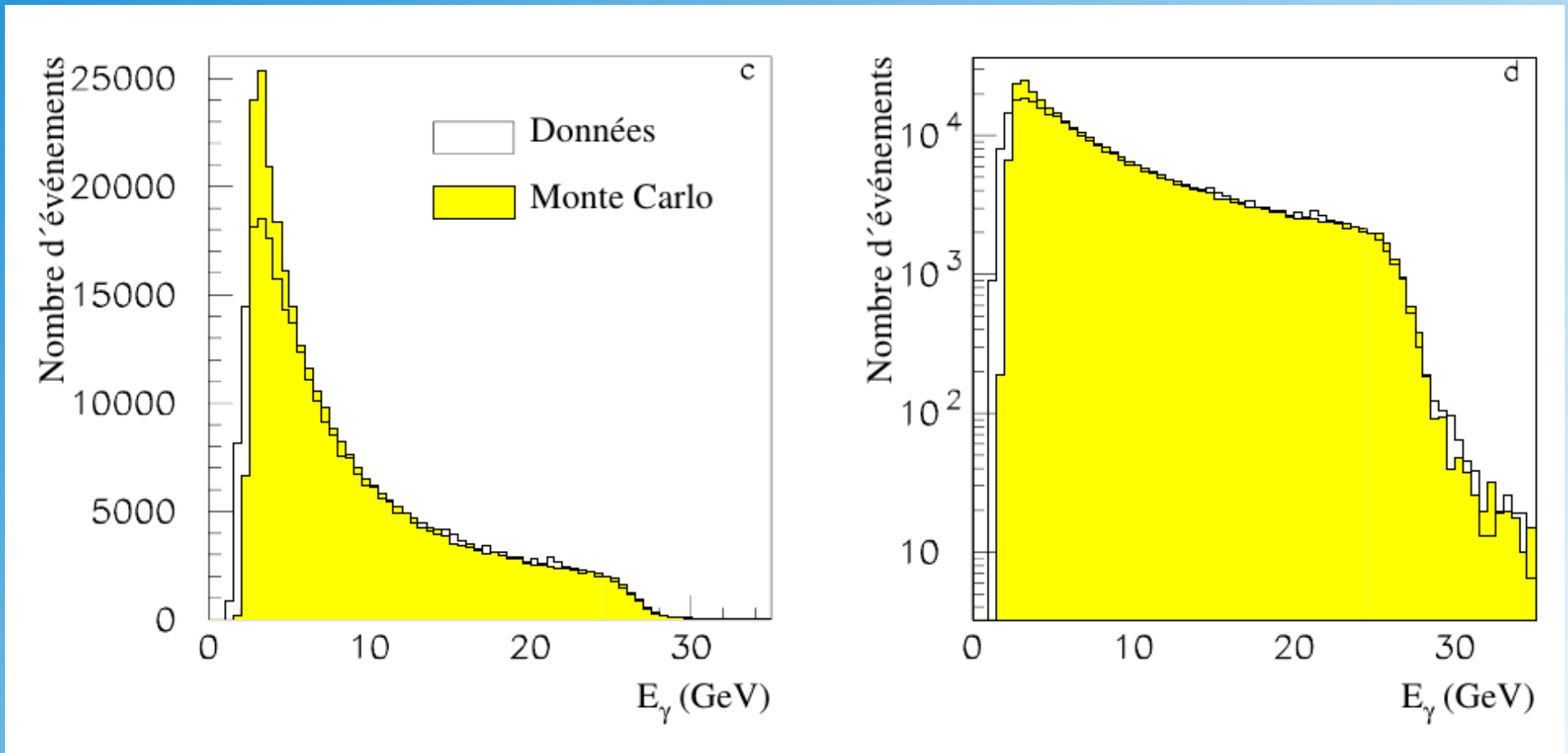

Principle of Luminosity Measurement

Integration of the instantaneous luminosity:

$$\mathcal{L}_b = \int_0^{\Delta T} L_b(t) dt$$

Relation between Photon counts, Bethe-Heitler cross section and integrated Luminosity

$$N_\gamma(E > \epsilon) = \mathcal{L}_b A \int_\epsilon^\infty \frac{d\sigma_{\text{BH}}}{dE} dE$$

Breakdown of Systematic Errors

Item	Online Actual	Offline Actual	Online Upgrade
Theoretical uncertainty	0.5	0.5	0.5
Trigger efficiency	0.1	0.1	–
Background subtraction	0.3	0.2	0.2
Pile up corrections	0.3	0.2	–
Photon detector acceptance	1.0	0.6	0.5
E-scale, resolution	2.0	0.7 – 1.2	0.6
p-bunch satellites	2.0	0.5 – 1.0	

Pileup Correction →

Effect of Pileup

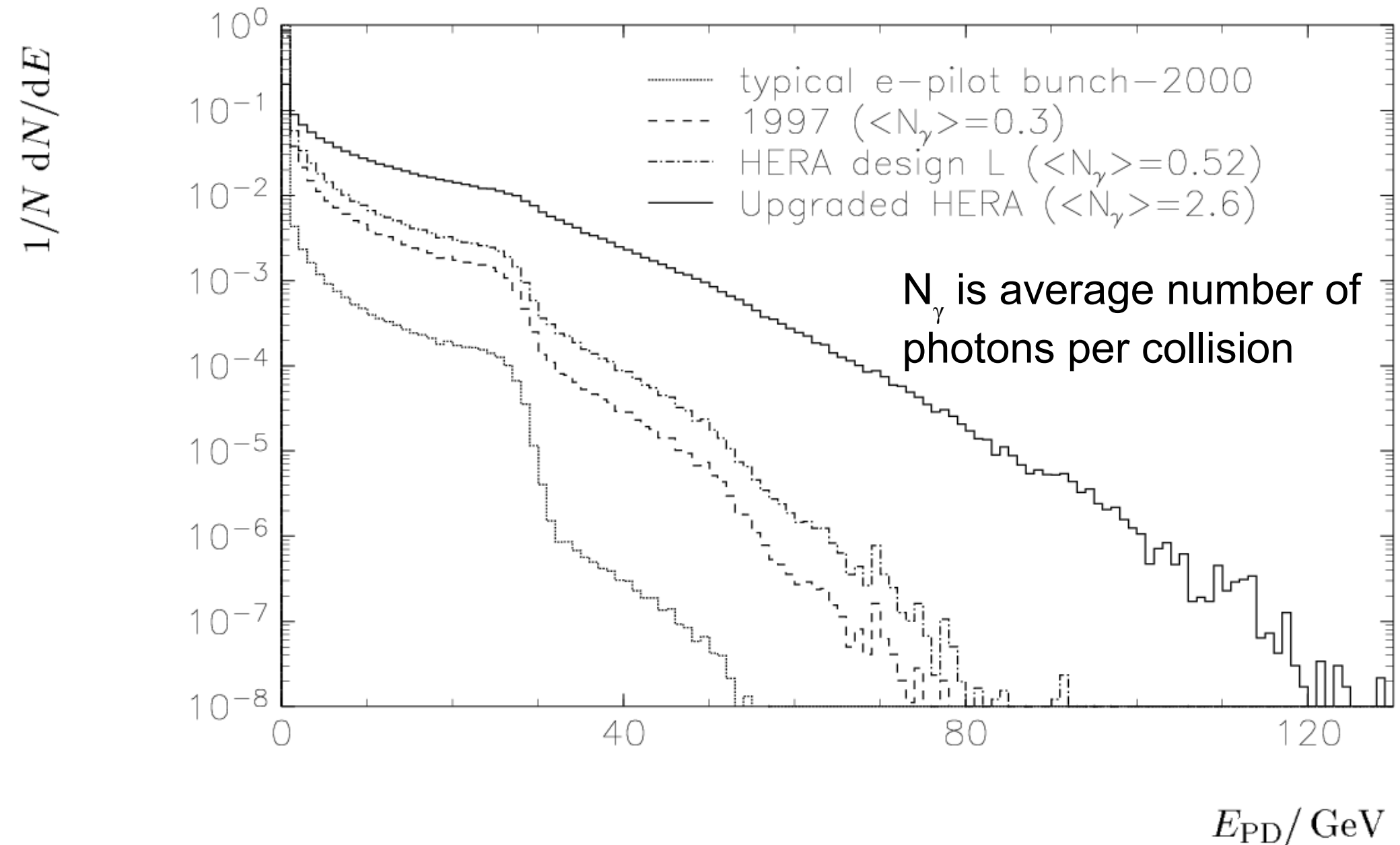

QED Compton Analysis

2nd method:

Determination of the Integrated Luminosity in the H1 Experiment at HERA using Elastic QED Compton Events

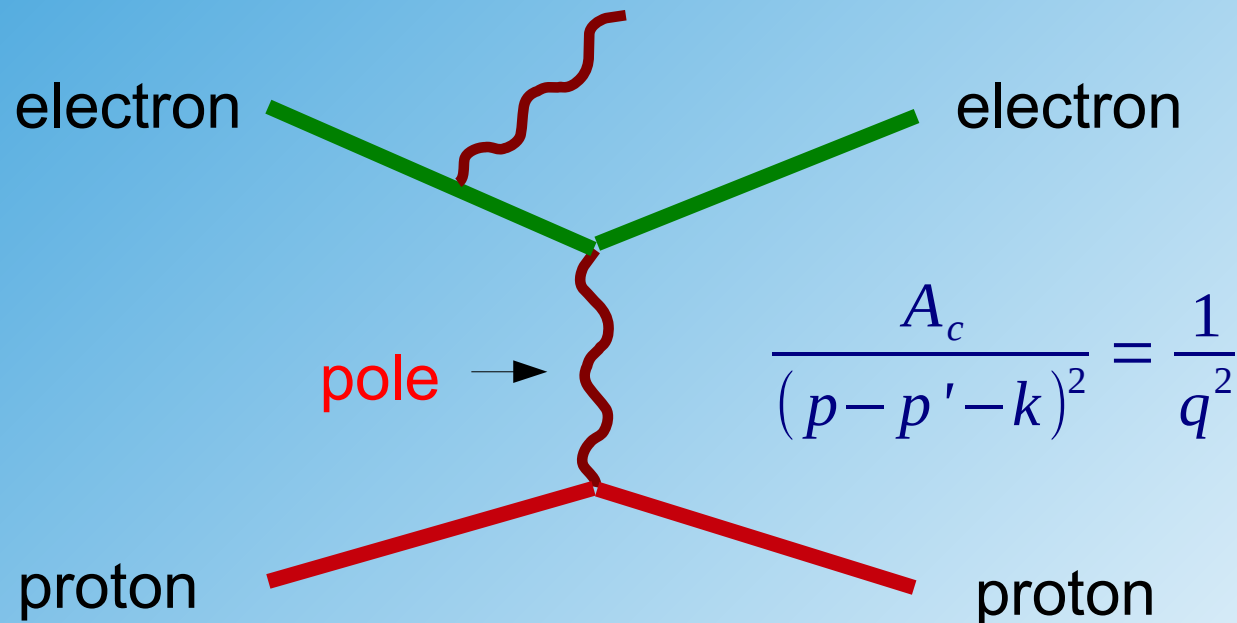

QED Compton Event

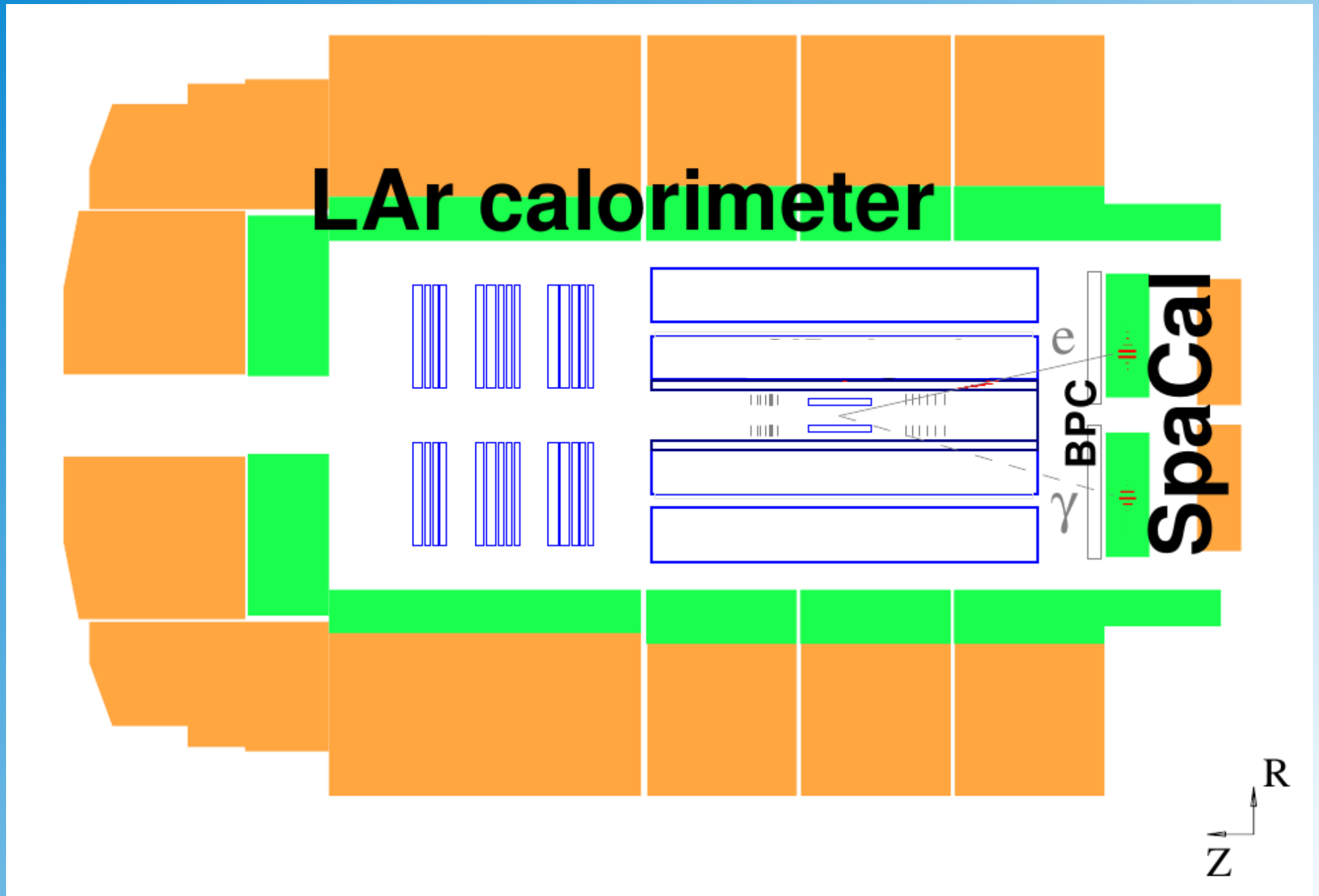

QED Compton Events

Back-to-Back Topology:

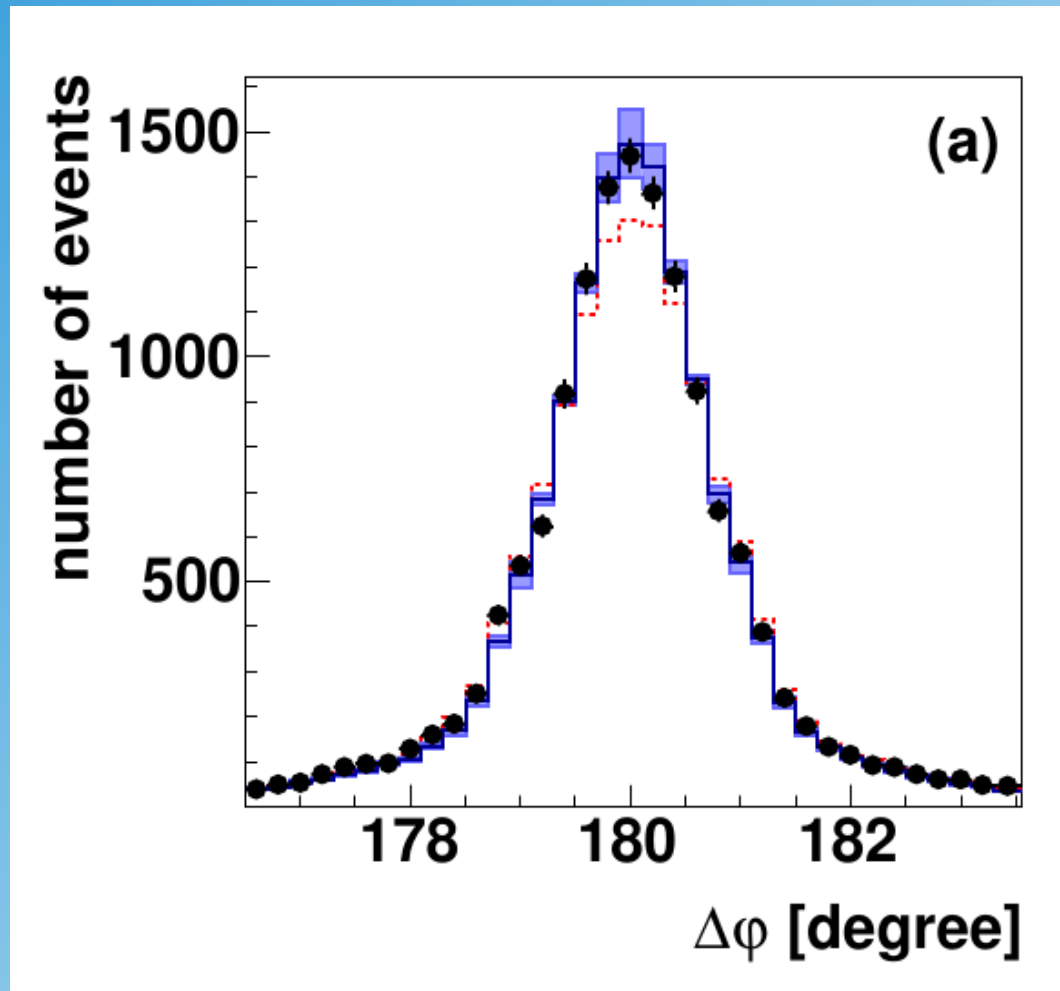

Radiative Corrections to Compton Events!

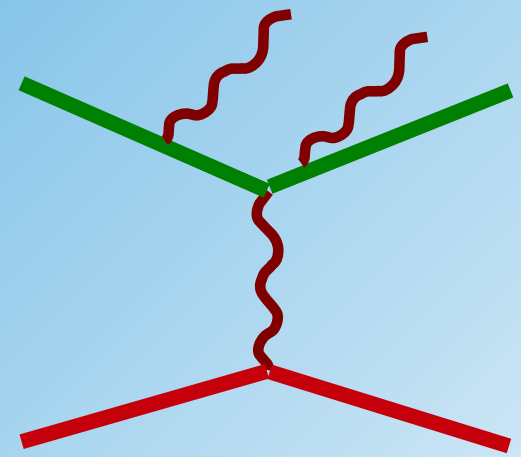
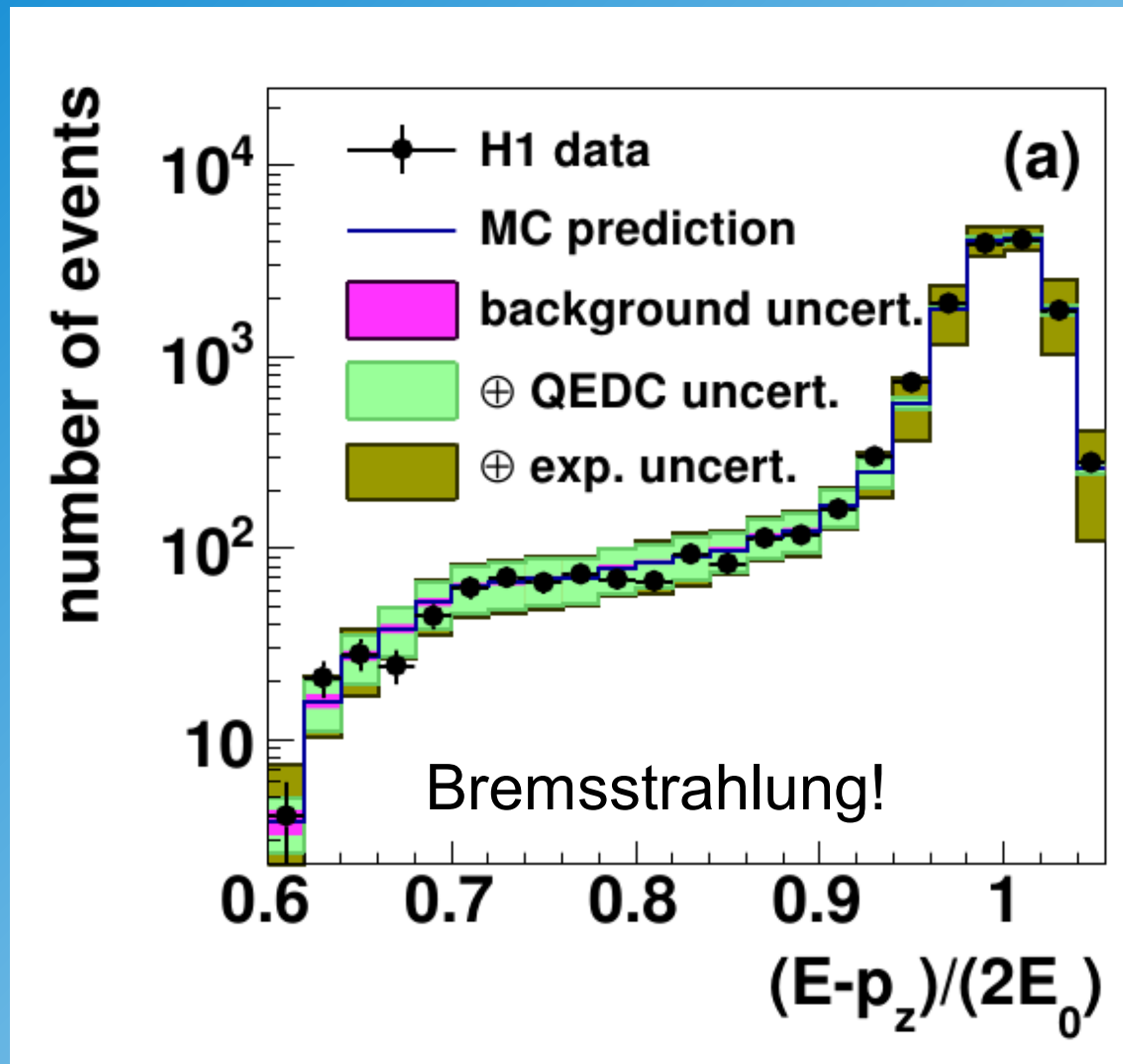

Uncertainties to Compton Analysis

Trigger uncertainties

Trigger efficiency	0.02%
Veto inefficiency	0.22%
	0.22%

Reconstruction uncertainties

SpaCal energy scale	0.56%
SpaCal energy resolution	1.10%
SpaCal position resolution	0.34%
CIP efficiency	0.18%
CIP resolution	< 0.01%
Conversion probability	0.33%
Alignment	0.39%
z -vertex distribution	0.24%
SpaCal cluster finder	0.04%
CTD efficiency	0.03%
LAr energy veto	0.05%
	1.41%

Background uncertainties

non-elastic QEDC	1.11%
elastic DVCS	0.25%
p -dissociative DVCS	0.08%
diffractive ρ	0.03%
diffractive ϕ	< 0.01%
diffractive ω	0.03%
diffractive J/ψ	0.03%
diffractive ψ'	0.08%
diffractive Υ	0.01%
non-resonant diffractive DIS	0.16%
$ep \rightarrow epe^+e^-$	0.13%
	1.17%

QEDC theory uncertainties

Higher order corrections	0.99%
Proton form factor	0.35%
	1.05%

total systematic error [in percent]: $0.22^2 + 1.41^2 + 1.17^2 + 1.05^2 = \mathbf{2.12^2}$

Bremsstrahlung in Charged Currents

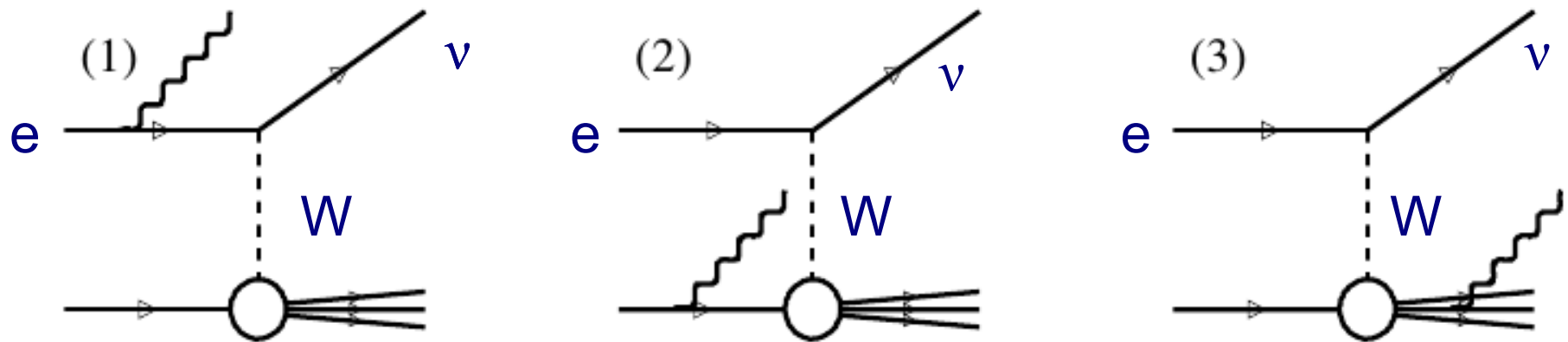
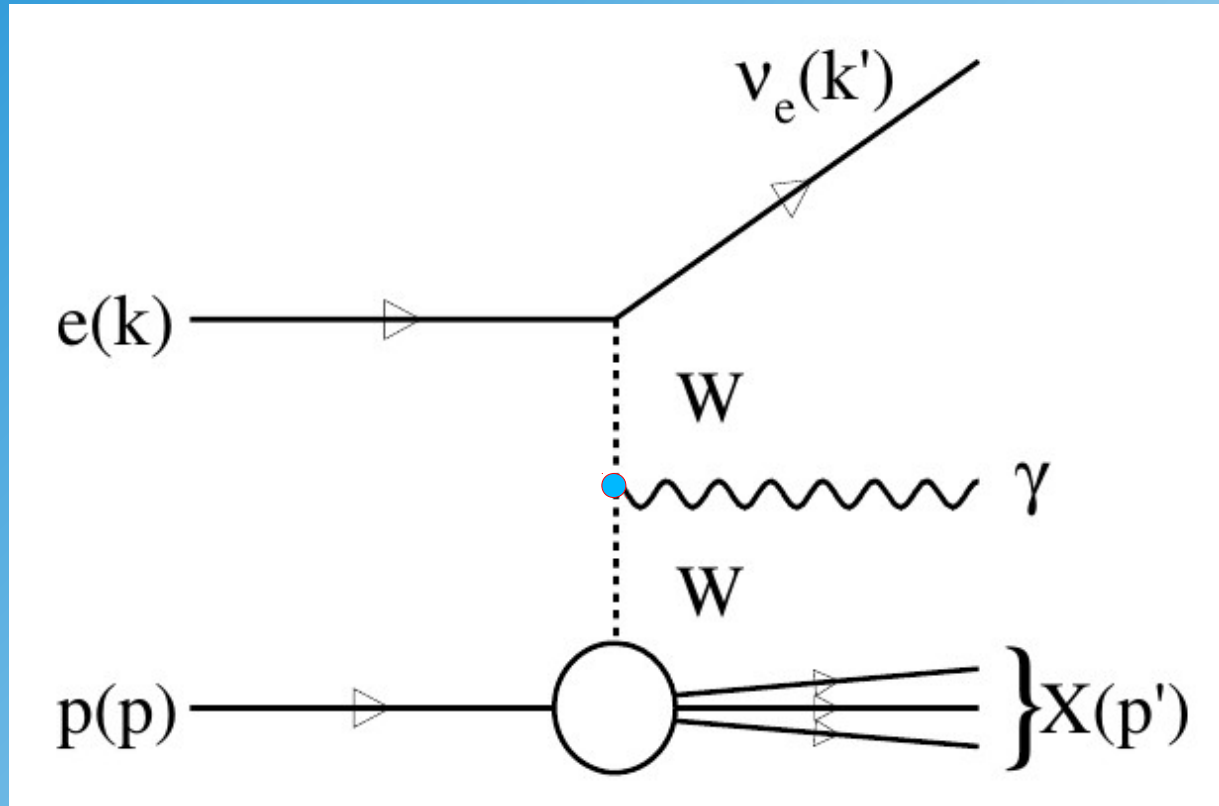

Figure 1.7: Feynman diagrams for scattering with radiation.

Neutrinos are not seen in detector and create missing p_T

Radiative Charged Current Events and W - W - γ Coupling



**The W -boson is electrically charged and can also radiate photons!
It is possible to test anomalous couplings**

Charged Current Event with Bremsstrahlung

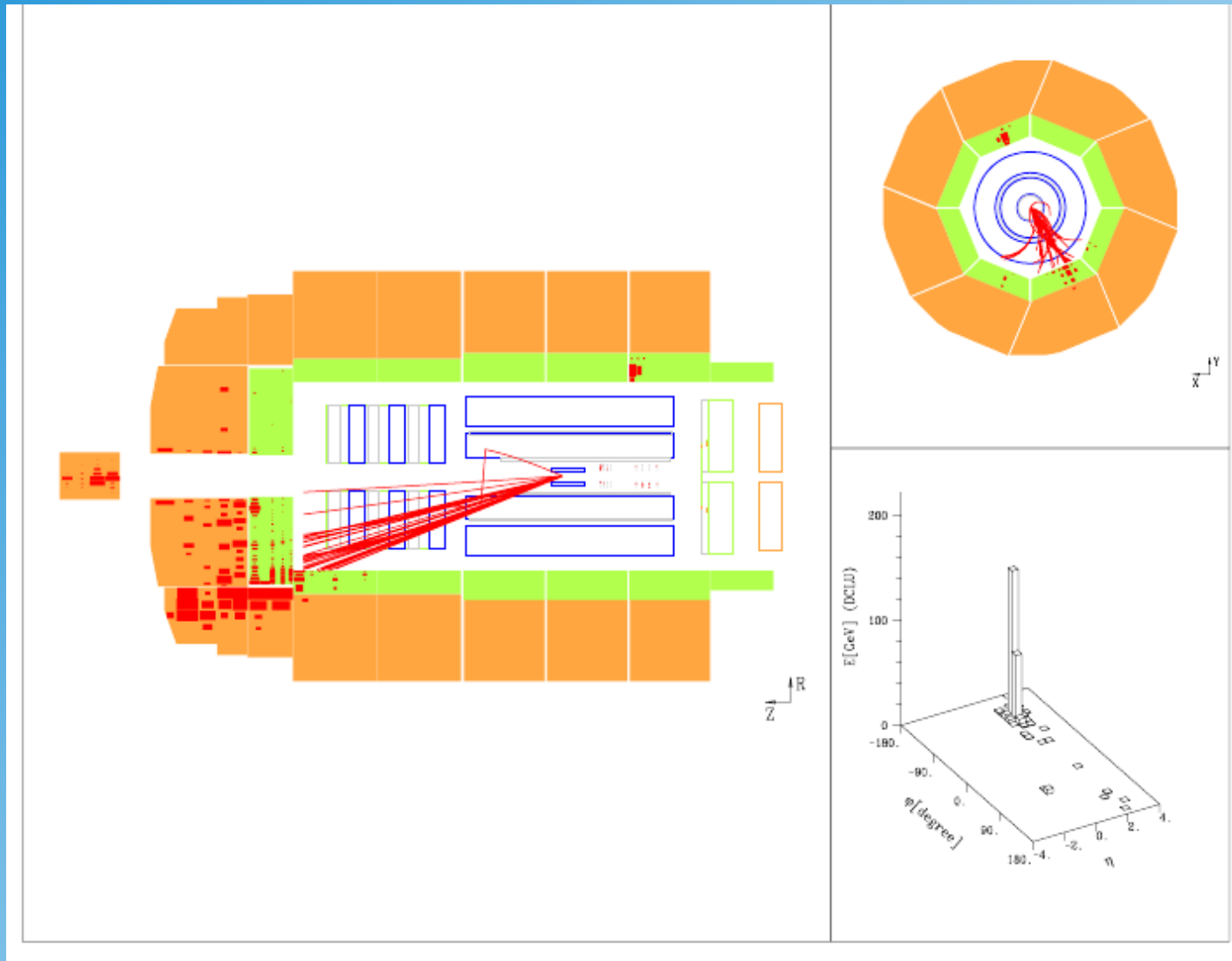

Radiative Corrections in CC events

Higher order leading logarithmic QED corrections to deep inelastic ep scattering at very high energies have significant impact on the kinematic reconstruction

These logarithmic QED corrections come from multiple photon emissions

→ systematic error of precision measurements

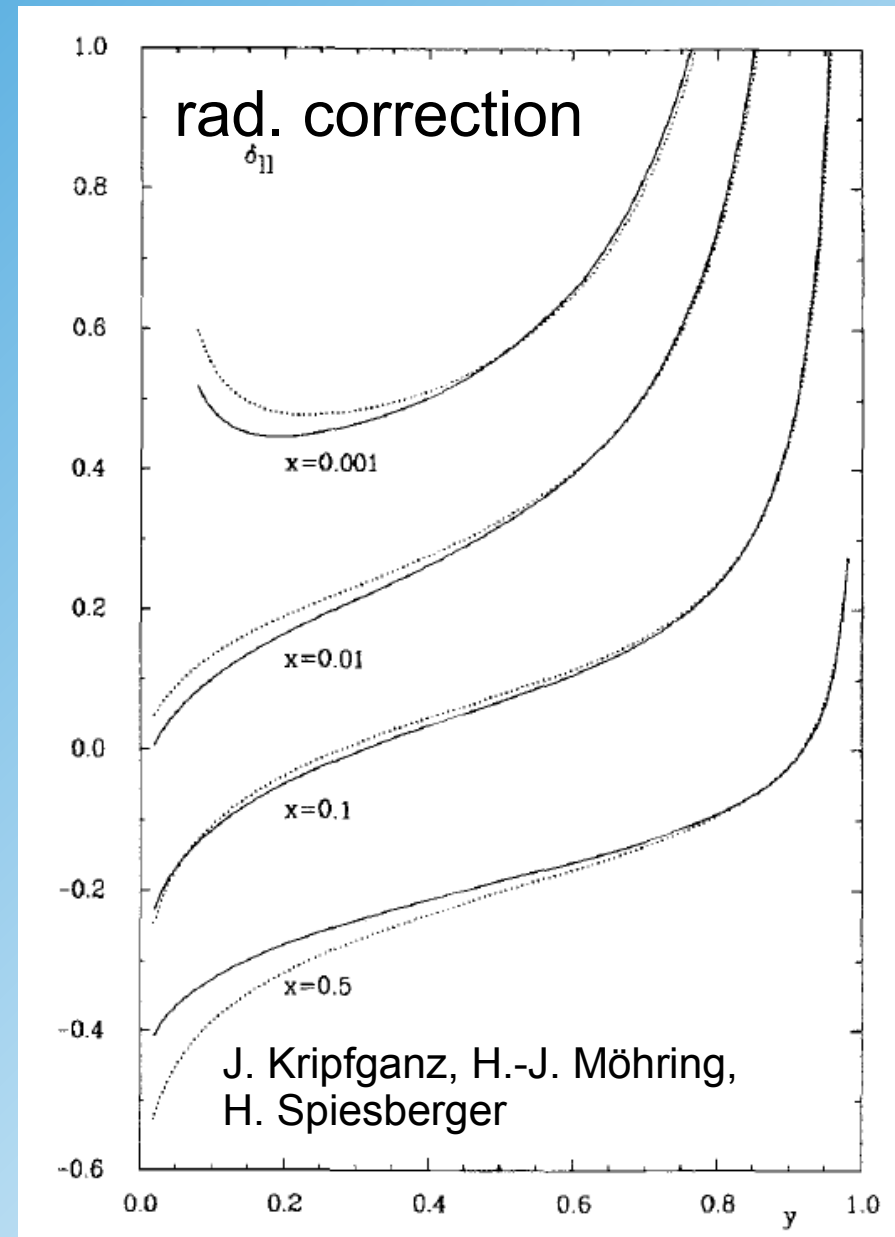

Higher Order Processes at HERA

e⁺ mu⁺ mu⁻

Alpha⁴ Processes at HERA

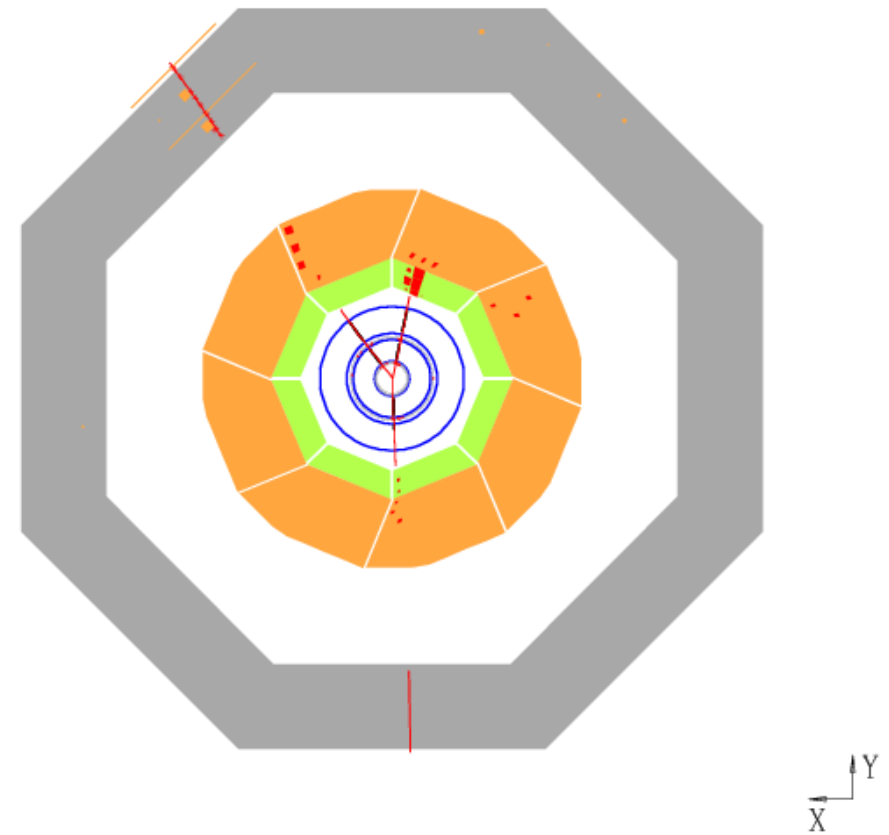
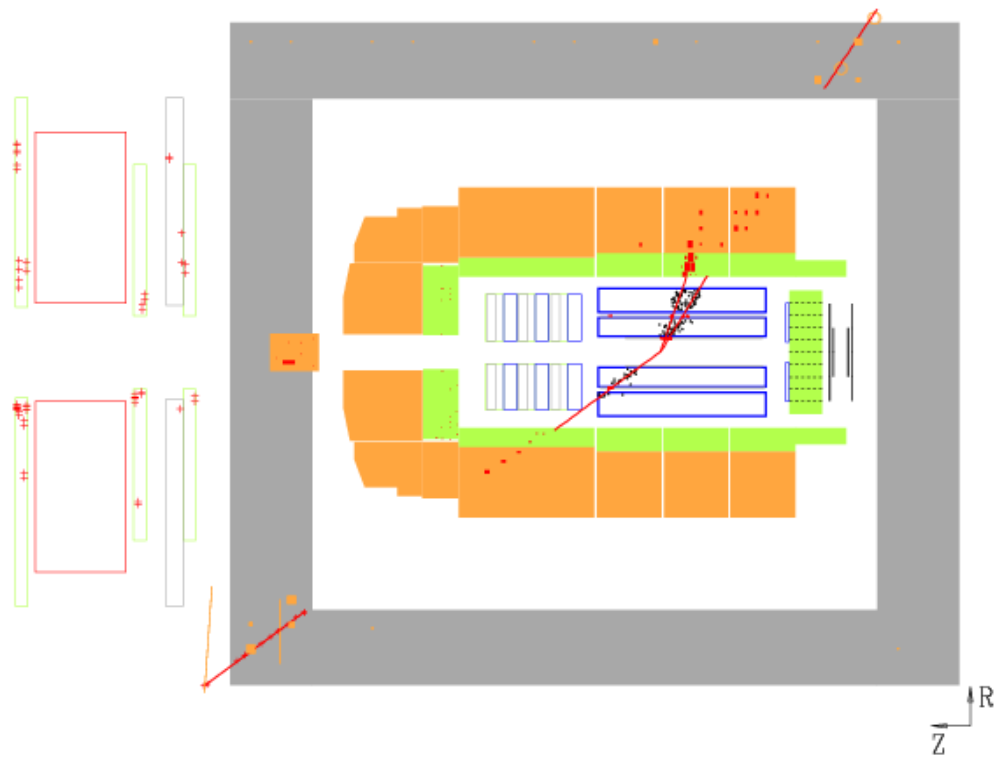

$$e^+ p \rightarrow e^+ X \mu^+ \mu^-$$

Alpha⁴ Processes at HERA

$$e^+ p \rightarrow X e^+ e^+ e^-$$

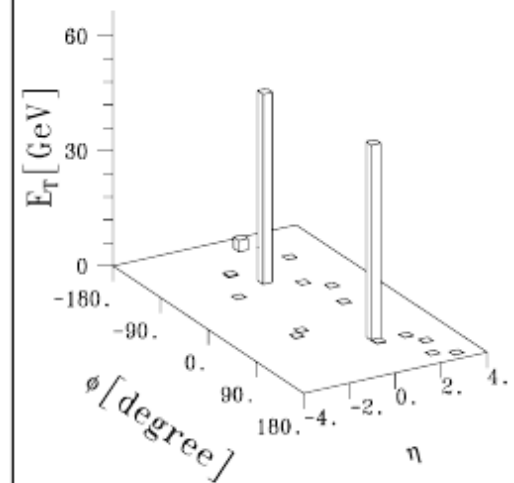
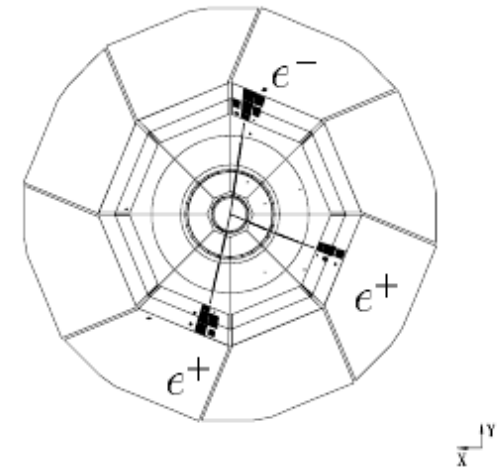
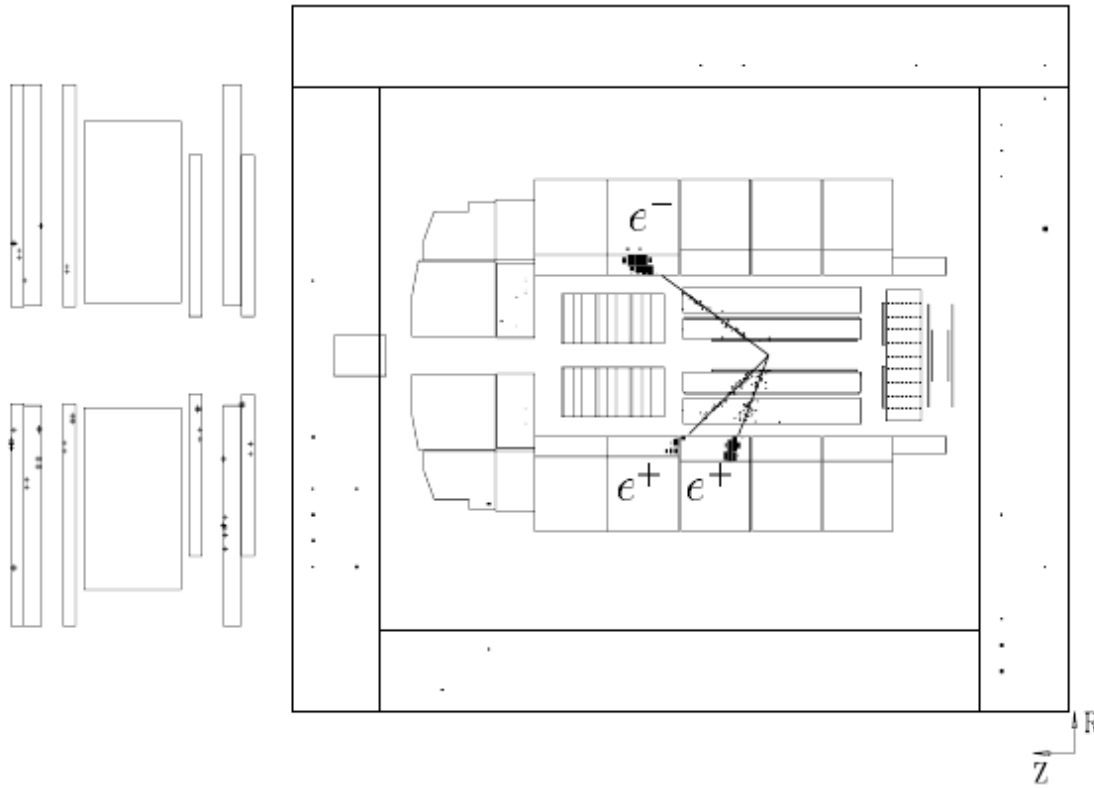

Exploitation of ISR

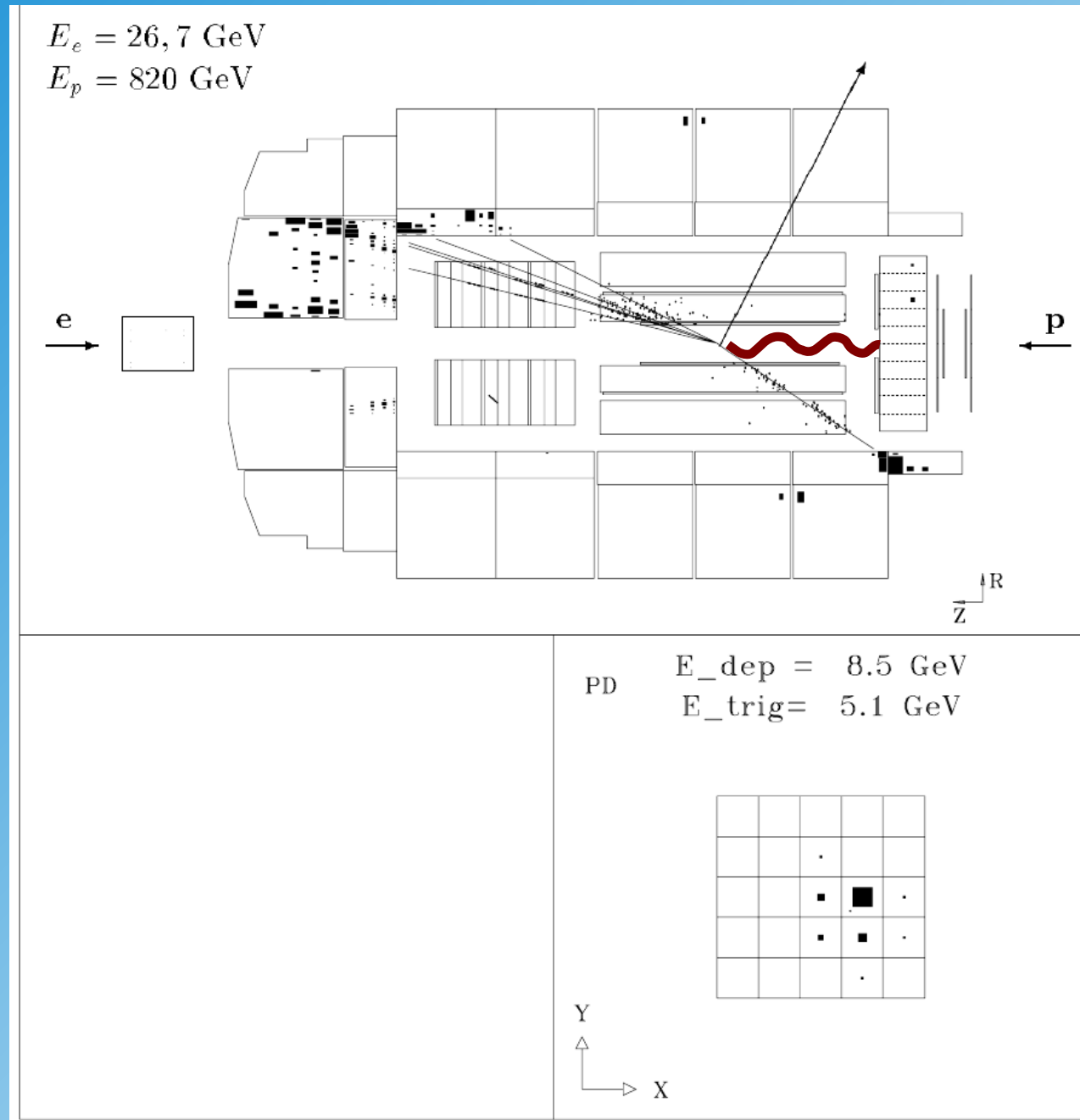

Exploitation of ISR

- ISR reduces the center of mass energy of the actual hard interaction
- This can be used to extend the kinematic phase space to lower energies

$$Q^2 = -q^2 = -(p - p')^2$$

allows to access smaller values of Q^2 which could not be reached otherwise!

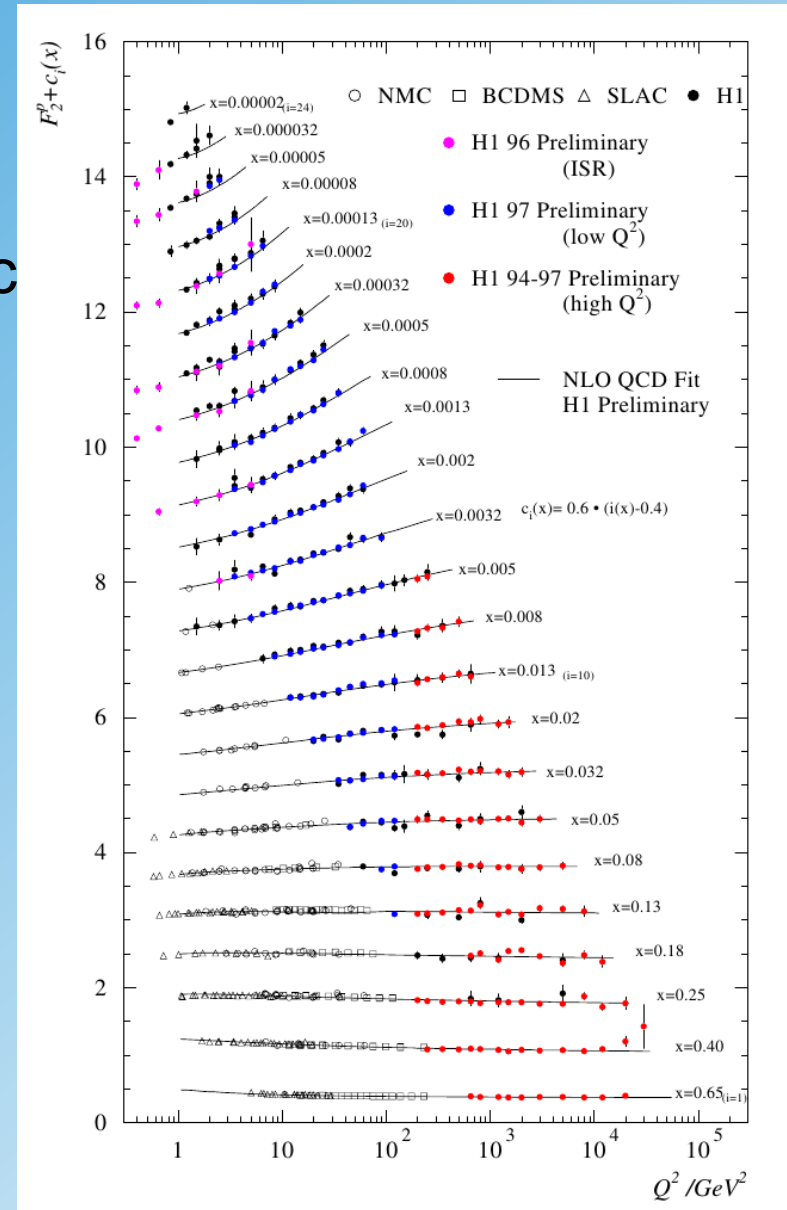

Exploitation of ISR

- ISR
- of the
- This
- pha

Q^2

allow
which

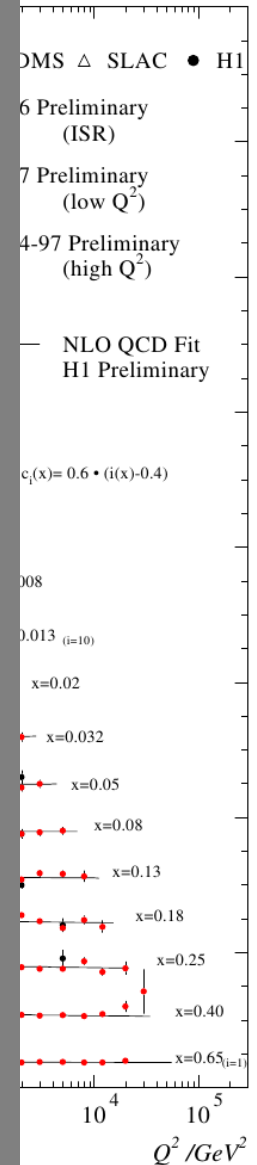
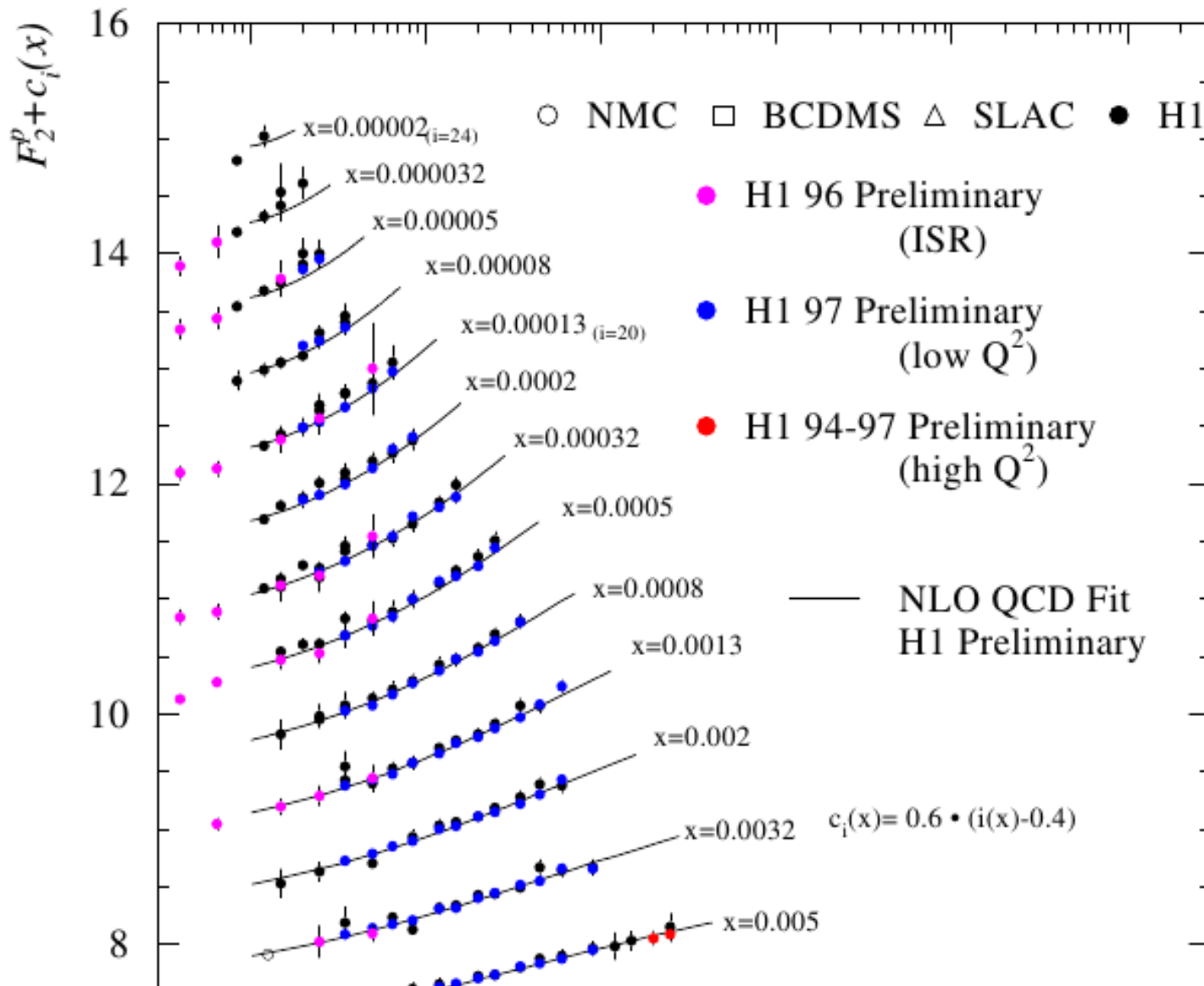

Radiative Returns

Z-boson are resonantly produced in $e^+ e^-$ collisions at resonance ($m_Z \sim 91$ GeV)

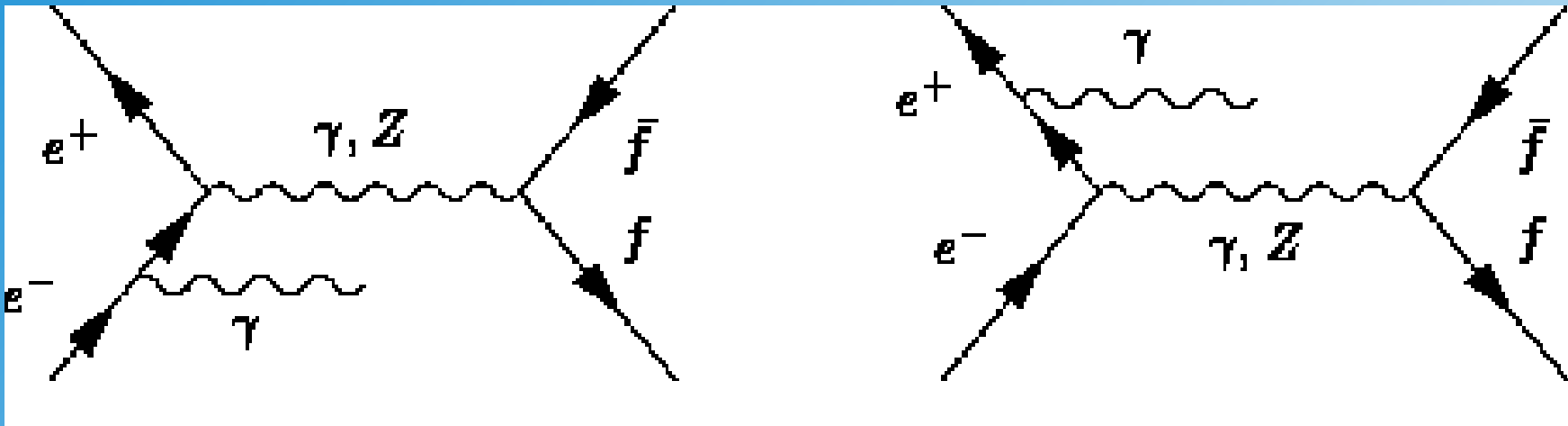

For $s^{1/2} > m_Z$ the radiative return allows a return to the resonance:

$$e^+ e^- \rightarrow Z \gamma$$

This effect can be large, e.g. at LEP

DELPHI Radiative Return Event at LEP

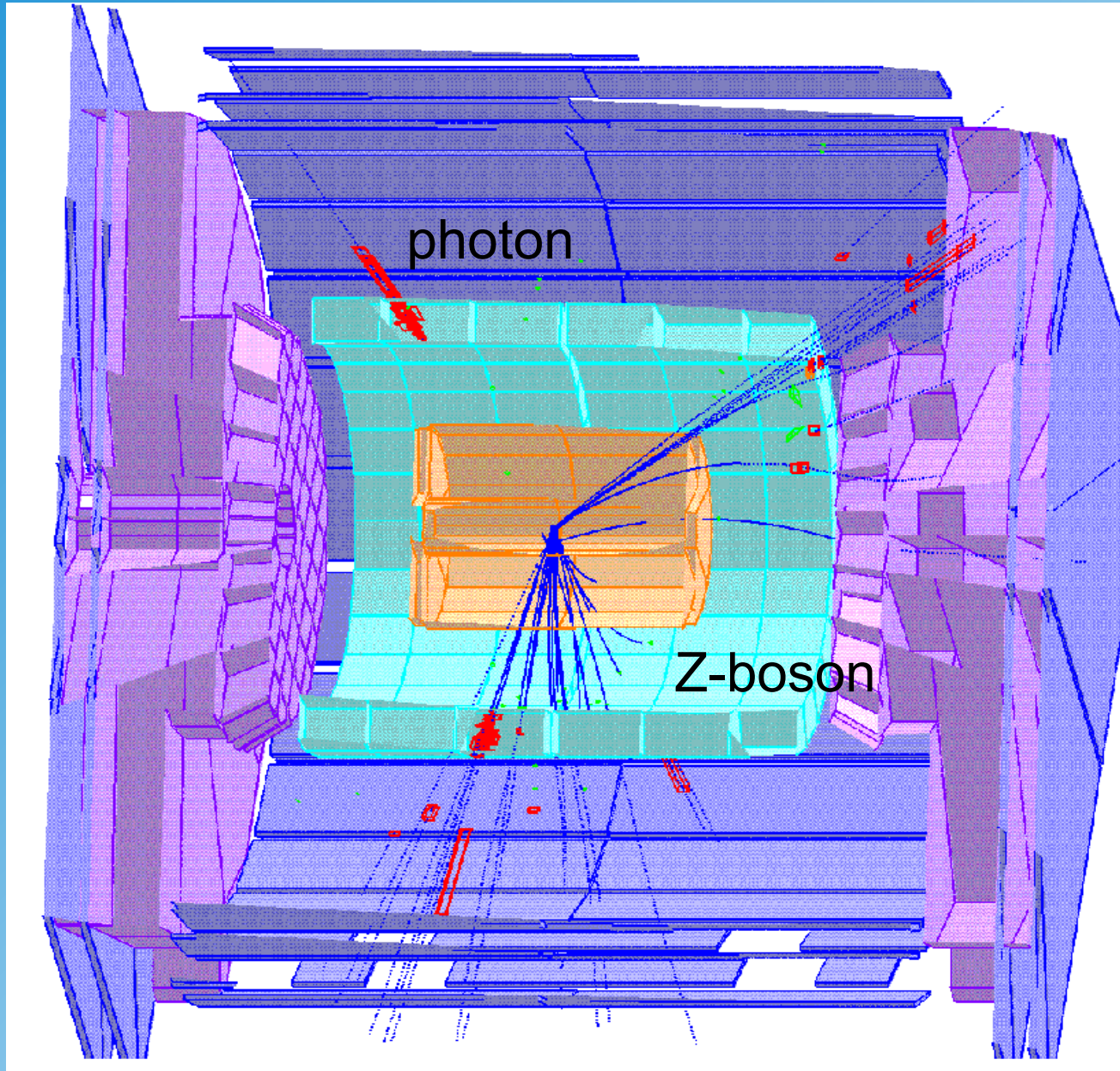

Measurement of Radiative Return

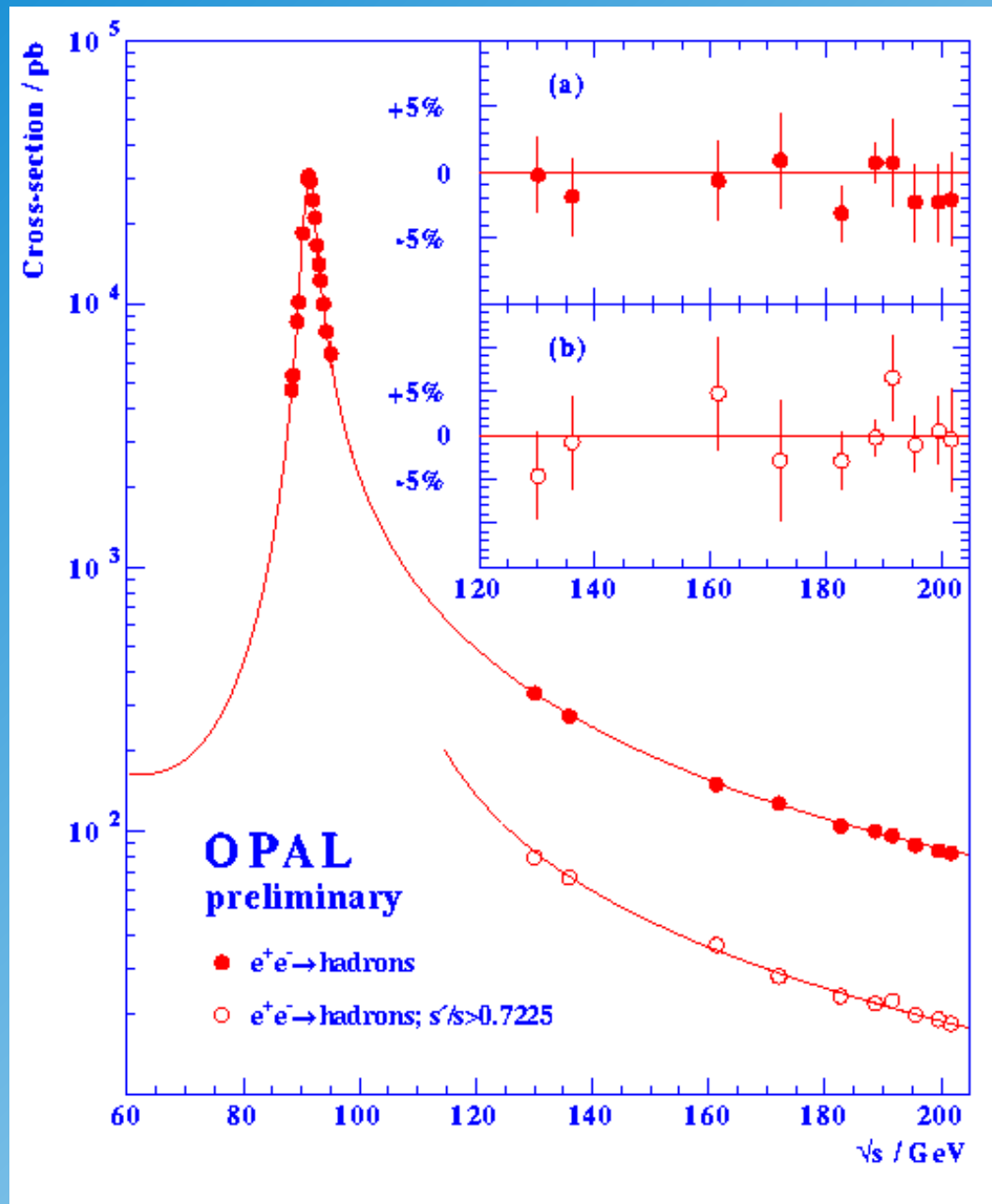

radiative returns
are extremely important!

incl. radiative return

no radiative return

Radiative Return at KLEO (Daphne)

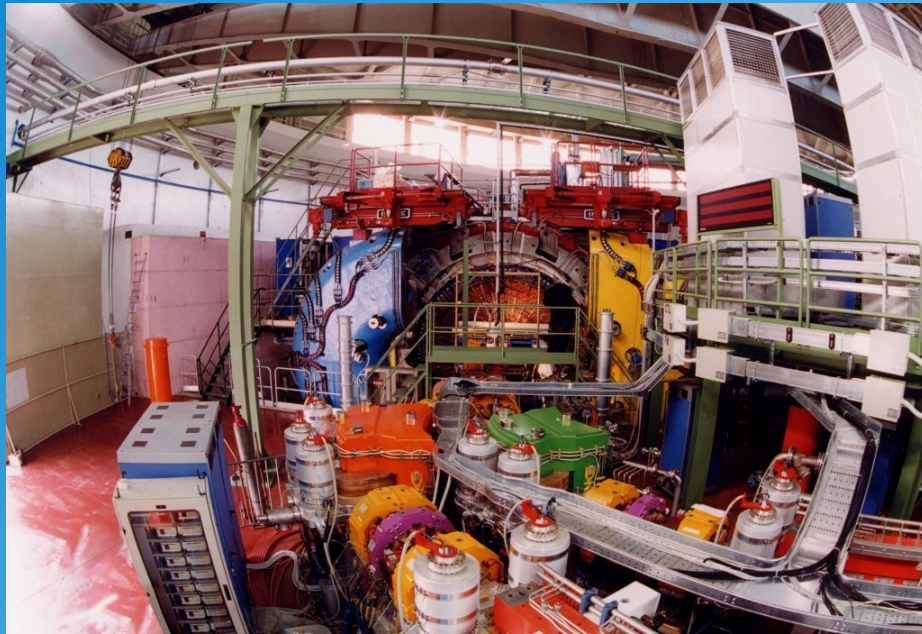

$e^+ e^-$ collider at $s^{1/2} = 1$ GeV

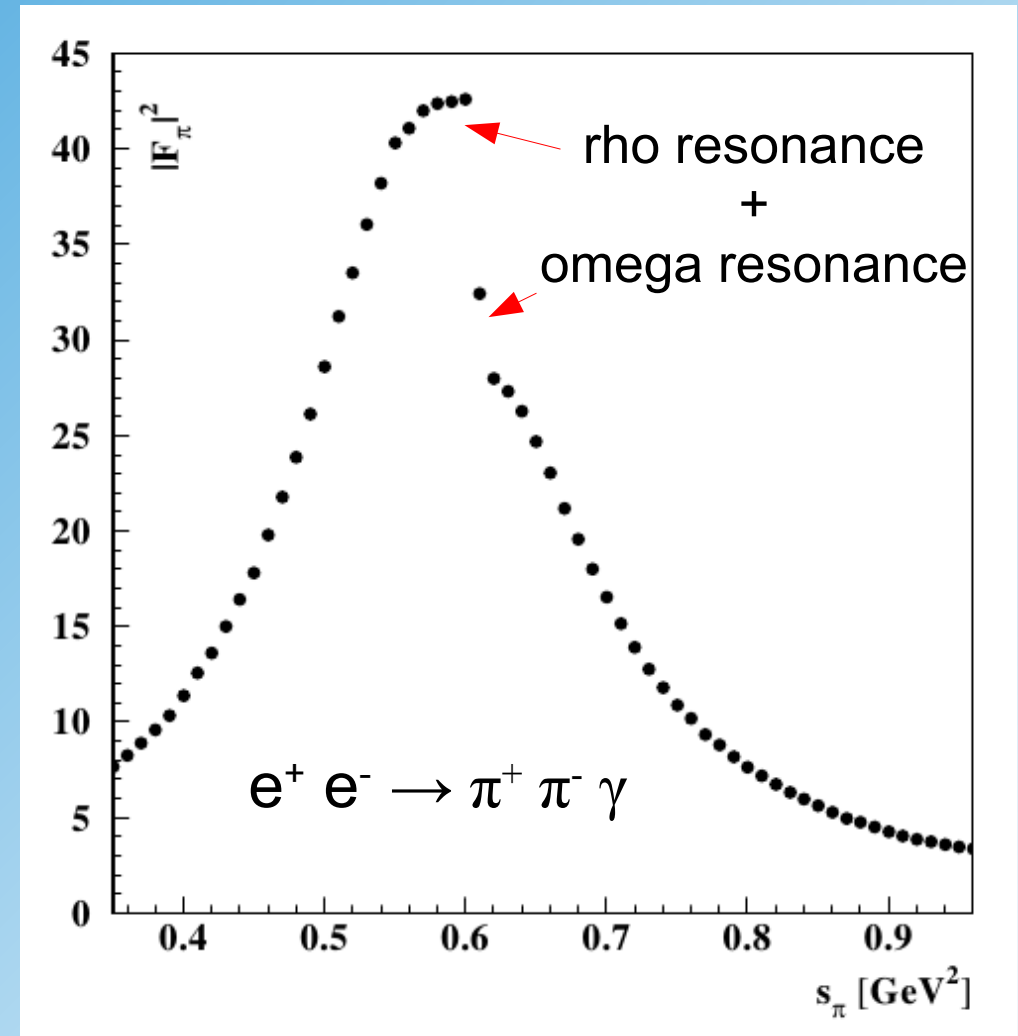
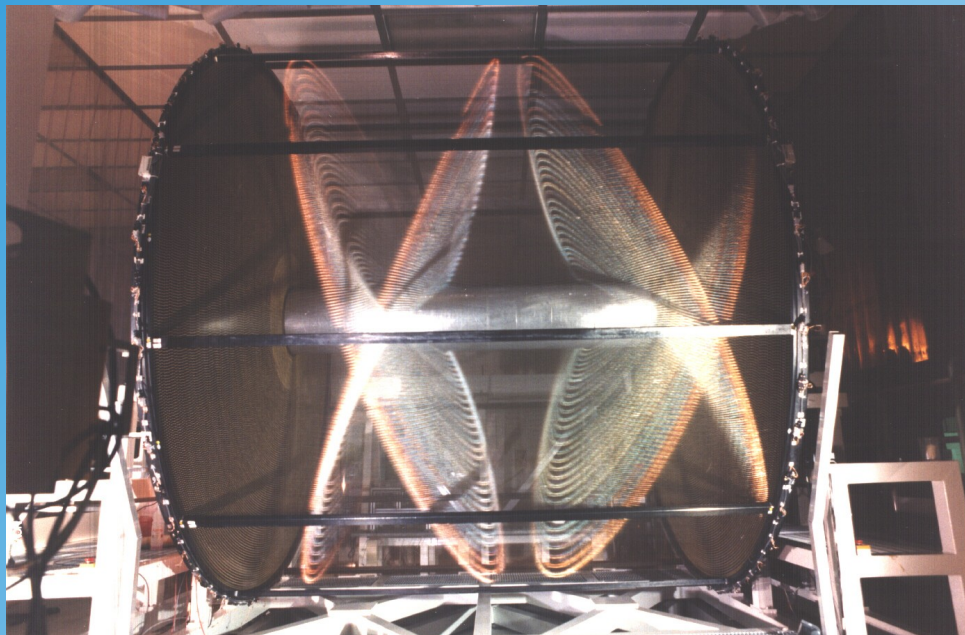

Radiative Returns at BABAR

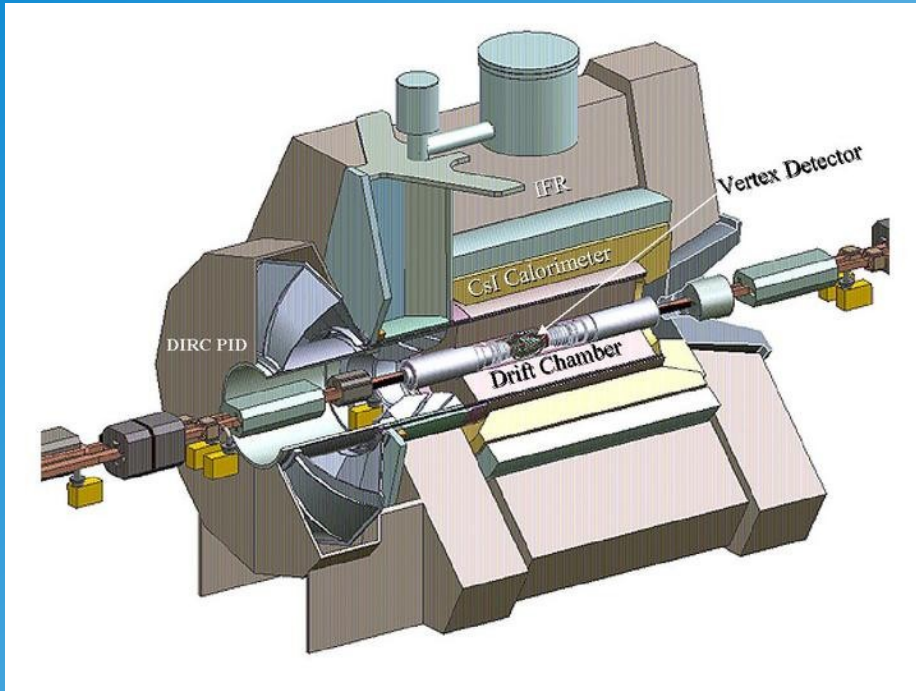

$e^+ e^-$ collider at $s^{1/2} = 10 \text{ GeV}$

$$e^+ e^- \rightarrow p \bar{p} \gamma$$

