

# Selected Topics on FE Electronics for the GERDA Phase II Ge detector readout

C.M. Cattadori  
INFN MiB

**Conference on Low Radiation Techniques 2015  
Seattle (WA) 18-20 March 2015**

# Outline

- GERDA experiment.
- GERDA II vs GERDA I FE architecture
- The Substrates
- Signal and HV Lines
  - Front End and HV Ribbon Cables
  - JFETs
  - Feedback Resistors
- Results achieved in GERDA commissioning runs
- Parylene coating
- Background Budget
- Conclusions

**All the measurements presented in this talk have been performed by the LNGS ICPMS and  $\gamma$ -ray screening teams. With their highly professional work, they provides unvaluable informations about material contaminations, allowing to proceed in the selection of materials for the setup construction.**

# GERDA @ LNGS: Searches of $0\nu\beta\beta$ of $^{76}\text{Ge}$

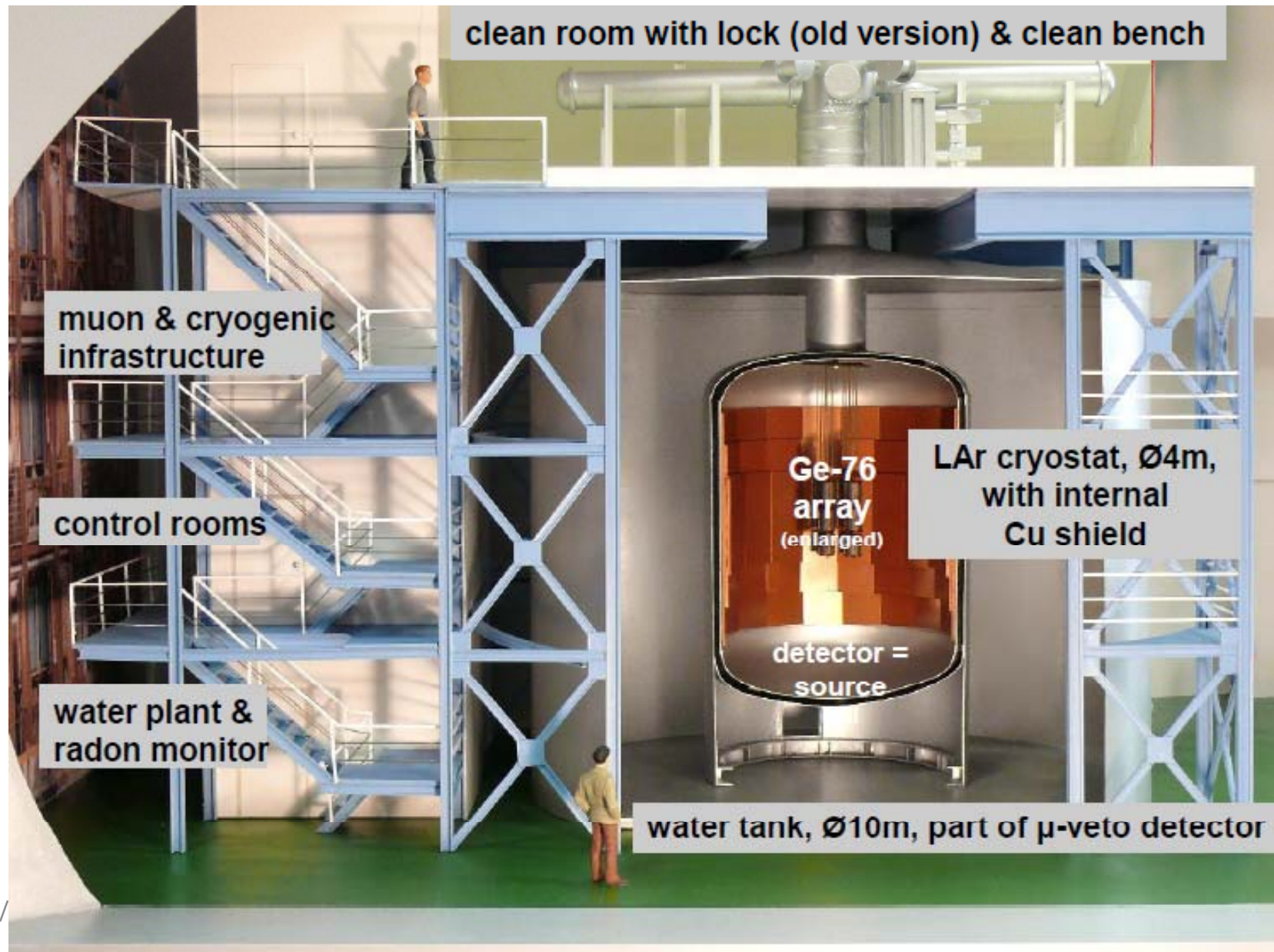

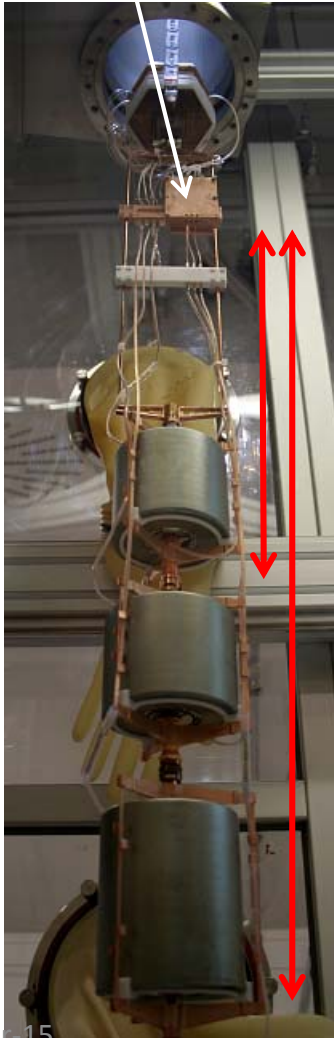
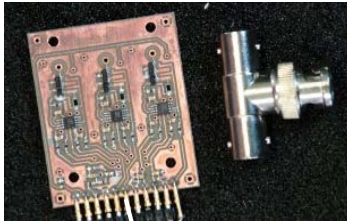

# GERDA Phase I

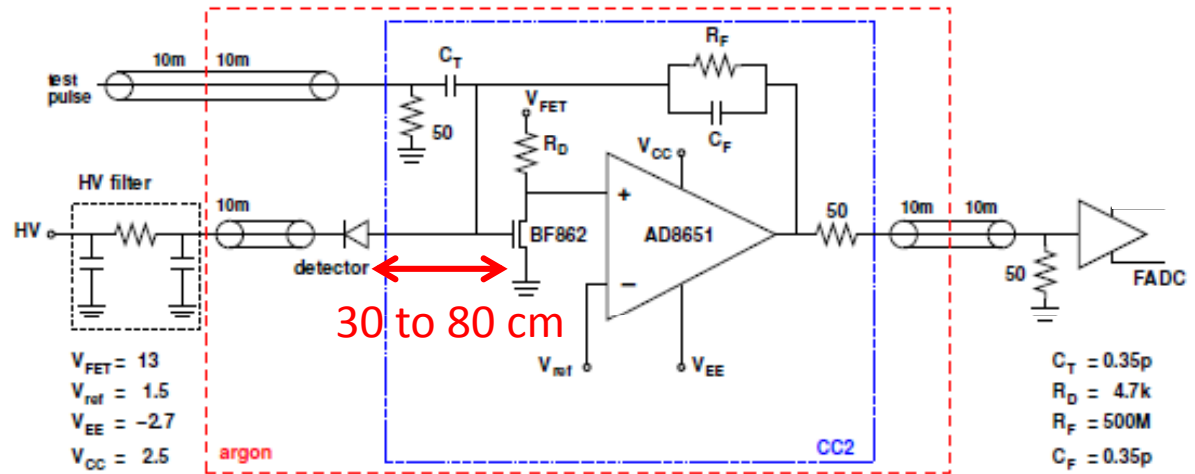

- **30 to 80 cm from detector readout electrode to CSA input**
- **Detector HV and readout contacts: spring loaded**
  - Because of activity issues FE device (JFET NPX-BF862) and CSA both **Located at about 30 to 80 cm above top detector**
  - Unshielded OFHC Cu strip to connect Detector to CSA input
  - $C_{Det} \sim 30$  pf
- **150  $\mu$ Bq Th-232 for 3 channels**
- **Microphonics (LF) and HF noise. Variable in time.**
- **Resolution and PSD suffered**

# Detector Performances improvement by tailored DSP

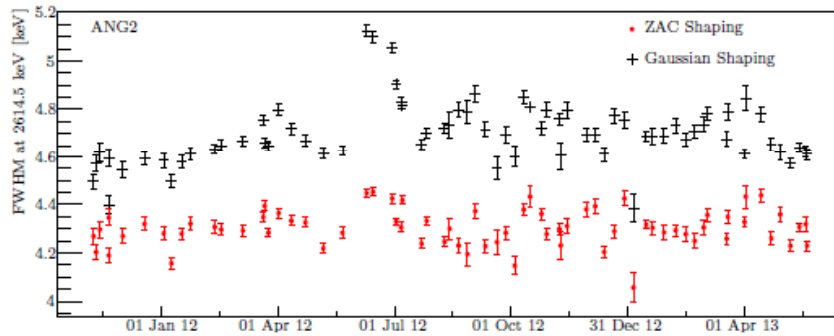

Fig. 10 FWHM of the  $^{208}\text{Tl}$  FEP for ANG2 during Phase I.

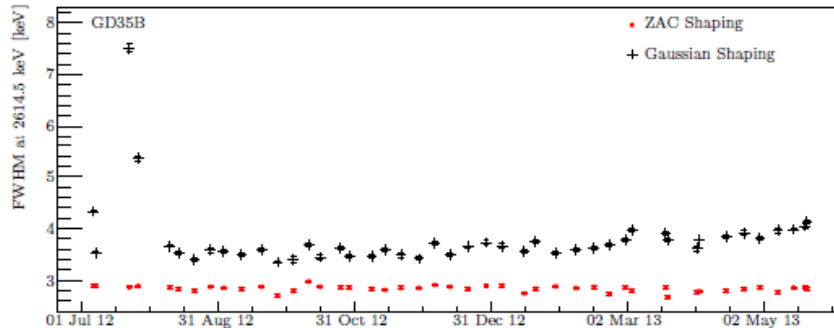

Fig. 11 FWHM of the  $^{208}\text{Tl}$  FEP for GD35B during Phase I.

**Table 3** Average FWHM over the complete Phase I period. The improvement is computed as the difference between the FWHM for the pseudo-Gaussian and that for the ZAC filter, weighted by the detector exposure. Only the statistical uncertainty due to the peak fit is quoted.

Detector	FWHM at $^{208}\text{Tl}$ FEP [keV] Gaussian	FWHM at $^{208}\text{Tl}$ FEP [keV] ZAC	Improvement [keV]
ANG2	4.712(3)	4.314(3)	0.398(4)
ANG3	4.658(3)	4.390(3)	0.268(4)
ANG4	4.458(3)	4.151(3)	0.307(4)
ANG5	4.323(3)	4.022(3)	0.301(4)
RG1	4.595(4)	4.365(4)	0.230(6)
RG2	5.036(5)	4.707(4)	0.329(6)
GD32B	2.816(4)	2.699(3)	0.117(5)
GD32C	2.833(3)	2.702(3)	0.131(4)
GD32D	2.959(4)	2.807(3)	0.152(5)
GD35B	3.700(5)	2.836(3)	0.864(6)

- Filtering with an improved filter, tailored for each detector  $\rightarrow$  Improved 10% FWHM both for Coax and BEGE & stability of reconstructed energy calibration

[arXiv: 1502.04392](https://arxiv.org/abs/1502.04392)

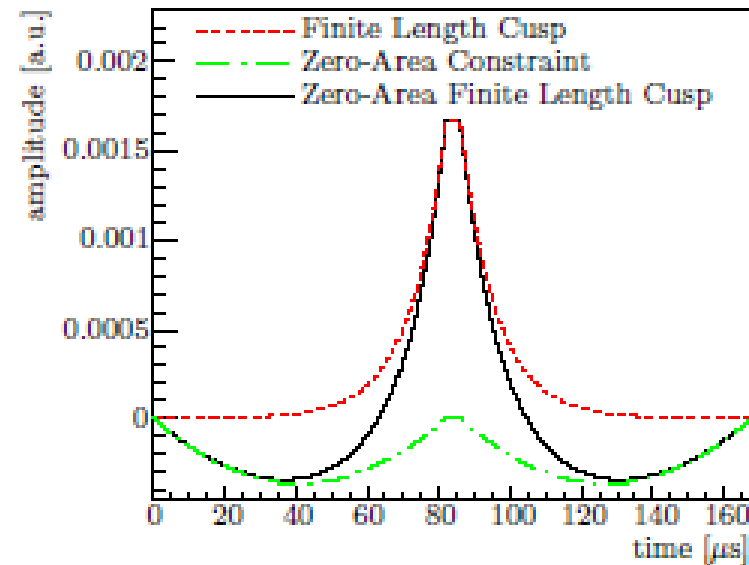

Fig. 5 The ZAC filter (black) is composed by the finite-length cusp (red dashed) from which two parabolas are subtracted on the cusp sides (green dash-dotted).



# GERDA PHASE II

**Aim: Reduce disturbances, microphonics, noise due to (variable) extracapacitance etc.**

- **Both Detector Contacts wire bonded**
- FE devices moved at detector site
- JFET changed to better match  $C_{det}$  (BEGe)
- JFET in die (die attach and bonded)

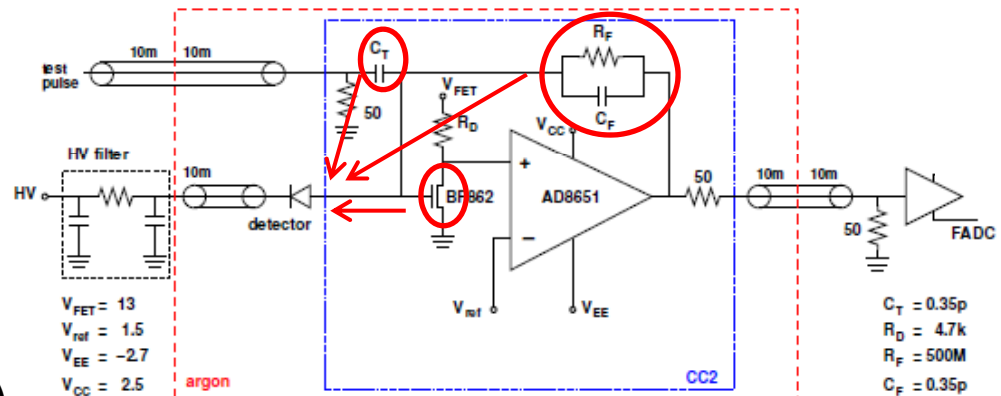

**More stringent radioactivity issues!**

Phase II detector assembly

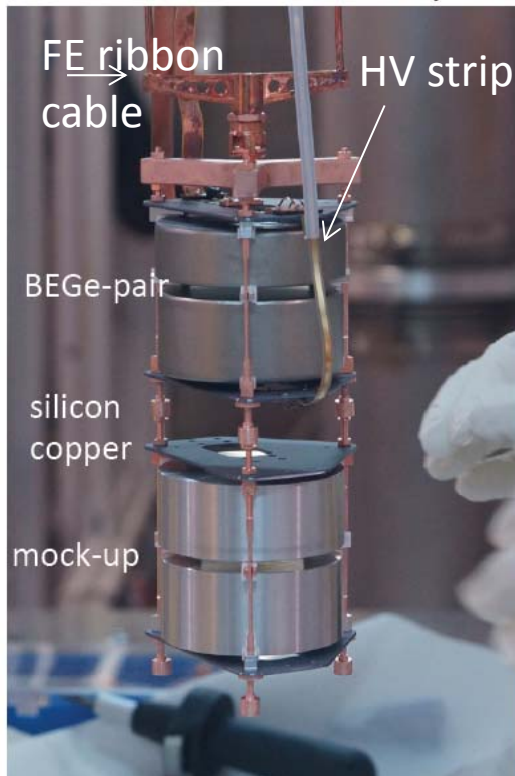

20-Mar-15

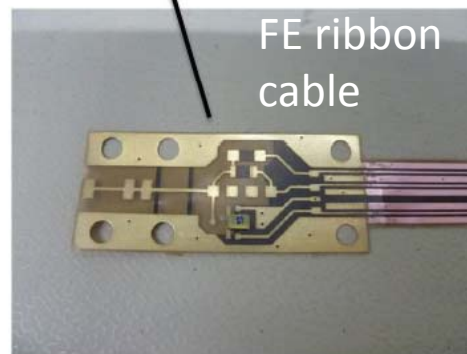
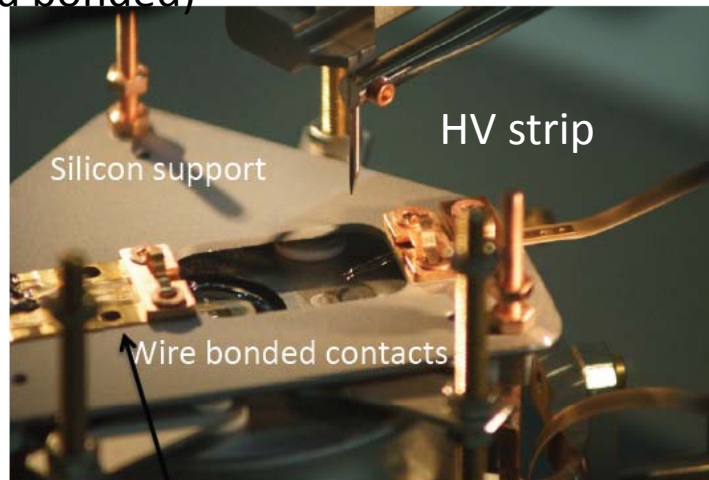

flex cables with JFET and feedback resistor/capacitor



Connection of ribbon cable to assembly

C. Cattadori - LRT 2015 - Seattle (WA)

# GERDA CC3 preamplifier

- 4 channel cryogenic charge sensitive preamplifier
- Extremely radio-pure electronics (<50 uBeq/ch)
- < 0.7 keV FWHM energy resolution (BEGe detectors)
- up to 80 cm long Cuflon VFE flex cables
- < 100 ns rise time (depending on VFE cable length)
- 15 MeV dynamic range
- < 70 mW power consumption/ch

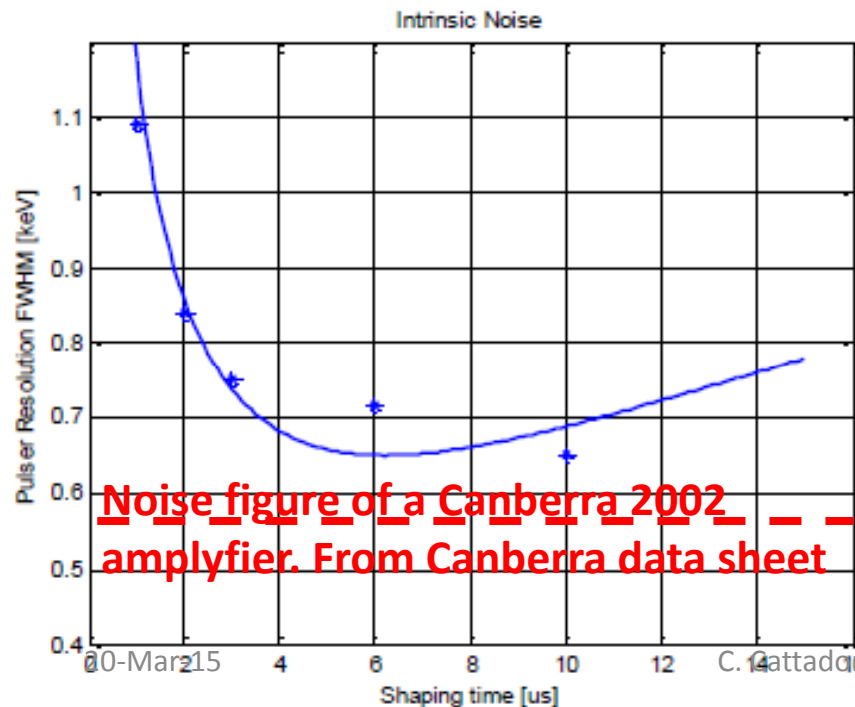

CC3 + adapters to coaxial and VFE cables (prototype aluminum holder)

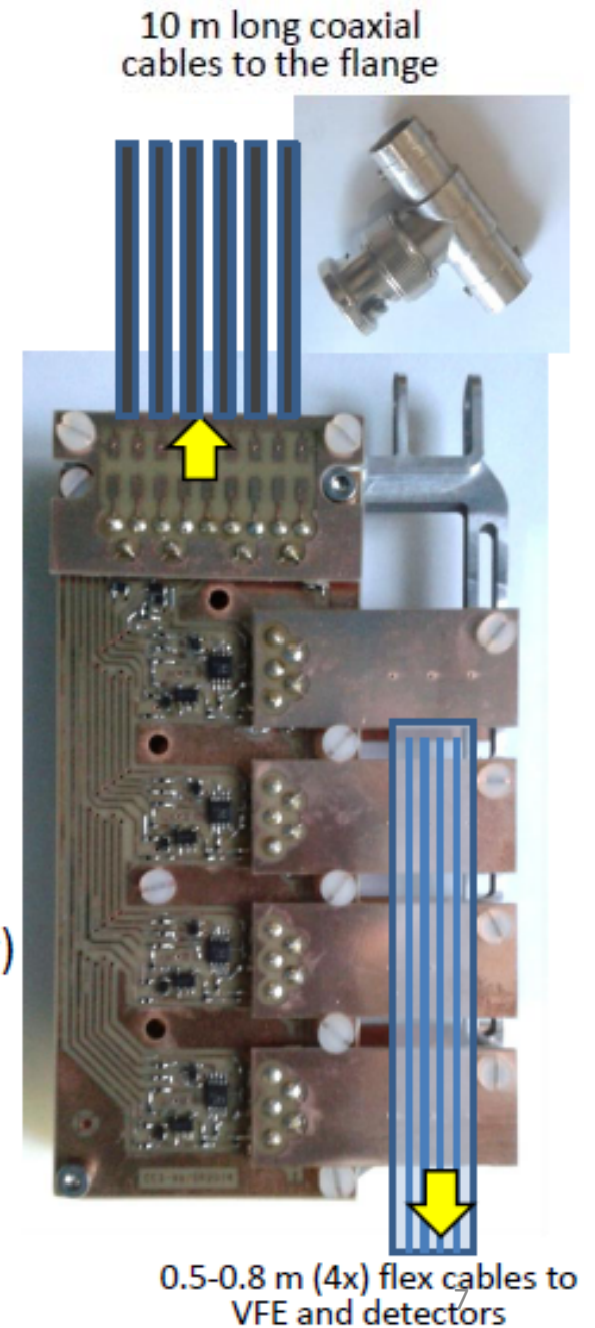

# Substrate of all the GERDA electronic circuits in LAr

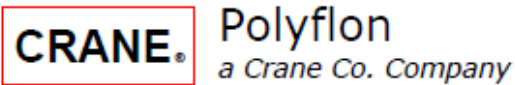

Polyflon Company  
 One Willard Road • Norwalk, CT 06851 USA  
 Phone: 203-840-7555 • Fax: 203-840-7565  
 email: [info@polyflon.com](mailto:info@polyflon.com) • [www.polyflon.com](http://www.polyflon.com)

## CuFlon® Microwave Substrates

Polyflon has taken advantage of the qualities of PTFE and coupled them with a proprietary plating process to produce a microwave substrate whose loss performance cannot be equaled by any other substrate available at this time.

PTFE has unique electrical and physical properties: low loss tangent and dissipation factor, very low dielectric constant, high volume and surface resistivity, high chemical inertness, and almost zero water absorption.

- |                              |                        |                 |                        |
|------------------------------|------------------------|-----------------|------------------------|
| <b>Features and Benefits</b> | • Ultra Low Loss       | • Very Low Dk   | • Isotropic Properties |
| <b>Typical Applications</b>  | • High Power Amplifier | • NRM/MRI Coils | • Couplers             |

Property	Value	Units	Direction	Frequency	Test Method/Condition
Dielectric Constant	2.05 +/- .05	-	Z	18 GHz	IPC-TM-650
Dissipation Factor	0.00045	-	Z	18 GHz	IPC-TM-650
Dielectric Strength (0.020")	1000	V/mil	Z	-	ASTM D 149
Volume Resistivity	10 <sup>16</sup>	ohm • cm	Z	-	ASTM D 257
Maximum Temperature	225	°C	-	-	Short Duration
Thermal Conductivity	0.25	W/m/°C	Z	-	ASTM C 518
Specific Gravity	2.15	-	-	-	ASTM D 792
Thermal Expansion	129	ppm/°C	X	-	ASTM E 831
(Unclad Dielectric)	129	ppm/°C	Y	-	ASTM E 831
	129	ppm/°C	Z	-	ASTM E 831
Water Absorption	<.01	%	-	-	ASTM D 570
Copper Peel (Average)	6-8	lbs/in	-	-	
Operating Temperature	-55 to 175	°C	-	-	
RoHS Compliant	Yes	Compliance Statement Available Upon Request			

GERDA has adopted Cuflon as PCB substrate for the

- Ge CSA PCBs
- PMT Voltage divider PCBs
- SiPM mountings

Cuflon **Pros:**

- ✓ OK  $\epsilon_r$ , cyogenic features and radiopurity
- ✓ Available in thicknesses down to 2 "mils (50 um)

Cuflon **Cons:**

- ❖ Available in panels of limited size → not suited to make long circuits
- ❖ Metalization of vias during the PCB manufacturing process is an issue





ELSEVIER

Contents lists available at ScienceDirect

Applied Radiation and Isotopes

journal homepage: [www.elsevier.com/locate/apradiso](http://www.elsevier.com/locate/apradiso)

Comparison of inductively coupled mass spectrometry and ultra low-level gamma-ray spectroscopy for ultra low background material selection

S. Nisi \*, A. Di Vacri, M.L. Di Vacri, A. Stramenga, M. Laubenstein

Laboratori Nazionali del Gran Sasso, INFN, S. S. 17/bis km 18+910, I-67010 Assergi (AQ), Italy

Sample	$^{40}\text{K}$ (mBq kg $^{-1}$ )	$^{232}\text{Th}$ (mBq kg $^{-1}$ )	$^{238}\text{U}$ (mBq kg $^{-1}$ )
<b>PEN</b>			
$\gamma$ -spectroscopy	510 $\pm$ 20	136 $\pm$ 3	242 $\pm$ 3 ( $^{226}\text{Ra}$ ) 236 $\pm$ 68 ( $^{234\text{m}}\text{Pa}$ )
ICP-MS	370 $\pm$ 50	110 $\pm$ 10	200 $\pm$ 30
<b>KAPTON<sup>®</sup> HN DuPont</b>			
$\gamma$ -spectroscopy	< 5.4	1.4 $\pm$ 0.7	14 $\pm$ 1 ( $^{226}\text{Ra}$ ) < 27 ( $^{234\text{m}}\text{Pa}$ )
ICP-MS	7 $\pm$ 3	0.65 $\pm$ 0.08	17 $\pm$ 2
<b>COOL CAT 2 Austrian Aerospace</b>			
$\gamma$ -spectroscopy	154 $\pm$ 32	1.9 $\pm$ 0.5	< 1.4 ( $^{226}\text{Ra}$ ) < 25 ( $^{234\text{m}}\text{Pa}$ )
ICP-MS	135 $\pm$ 4	0.50 $\pm$ 0.02	1.43 $\pm$ 0.09
<b>NAC-2 Air Liquide</b>			
$\gamma$ -spectroscopy	81 $\pm$ 19	5.0 $\pm$ 2.0	22 $\pm$ 2 ( $^{226}\text{Ra}$ ) < 70 ( $^{234\text{m}}\text{Pa}$ )
ICP-MS	86–4/+5	7.2 $\pm$ 0.3	23.6 $\pm$ 0.9
<b>CuFlon<sup>®</sup></b>			
$\gamma$ -spectroscopy	48 $\pm$ 15	< 1.9	< 0.84 ( $^{226}\text{Ra}$ ) < 132 ( $^{234\text{m}}\text{Pa}$ )
ICP-MS	6–2/+9	0.28–0.03/+0.04	0.36–0.04/+0.07

The uncertainties are given with one standard deviation

## Typical activity values measured for Cuflon material at the ICPMS and STELLA $\gamma$ -screening facilities @ LNGS

Values can slightly change following substrate thicknesses and Cu/Teflon fraction

**Cuflon cleaner than Kapton**  
**factor 15 in Ra-226**  
**factor 40 in U-238**

· Seattle (WA)

# Features of FE Ribbon cables (Coplanar Waveguides)

- Substrates :
  - Cuflon 50-75  $\mu\text{m}$  :  $\epsilon_r=2.1$
  - Kapton 50-75  $\mu\text{m}$ :  $\epsilon_r=3.4$
- Lengths to connect different detectors to CSA:
  - 48 cm to 80 cm

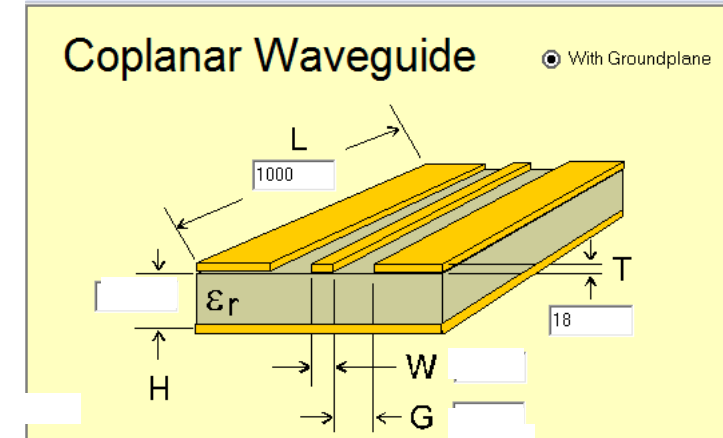

IMPORTANT: Regular waveforms only if

- Impedance properly matched
- Extra C introduced by the long capacitive line compensated at the amplifier relevant node  $\rightarrow$
- To preserve pulse rise time keep trace C as low as possible

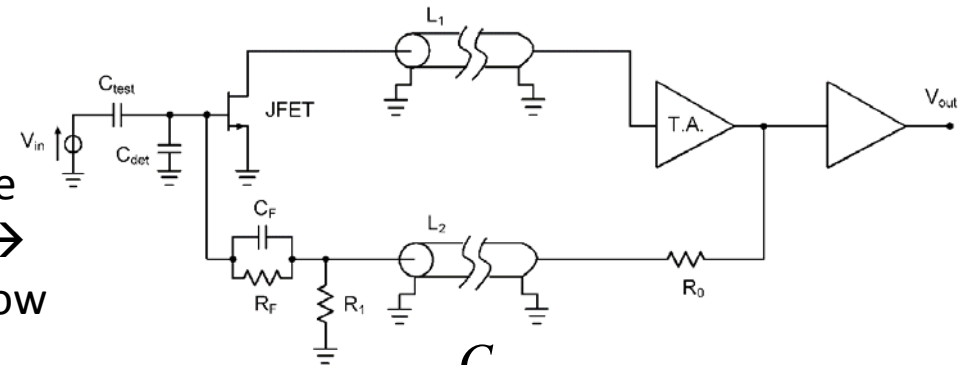

$$\tau_{RT} \sim C_T \frac{C_{ampnode}}{C_F \times g_m}$$

$$C_t = C_D + C_F + C_{In}$$

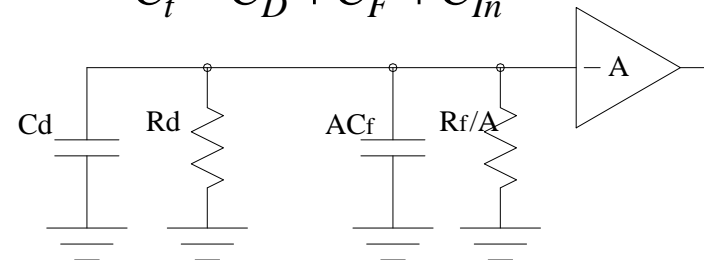

	Thick ness	$Z_0$ [Ohm]	C [pF/m]	v/c %
Kapton	50 $\mu\text{m}$	27	290	59
	75 $\mu\text{m}$	37	180	60
Cuflon	50 $\mu\text{m}$	34	165	73
20-Mar-15	75 $\mu\text{m}$	46	102	74

# Impact of cable length between the FE devices and the amplifying node in a closed loop CSA

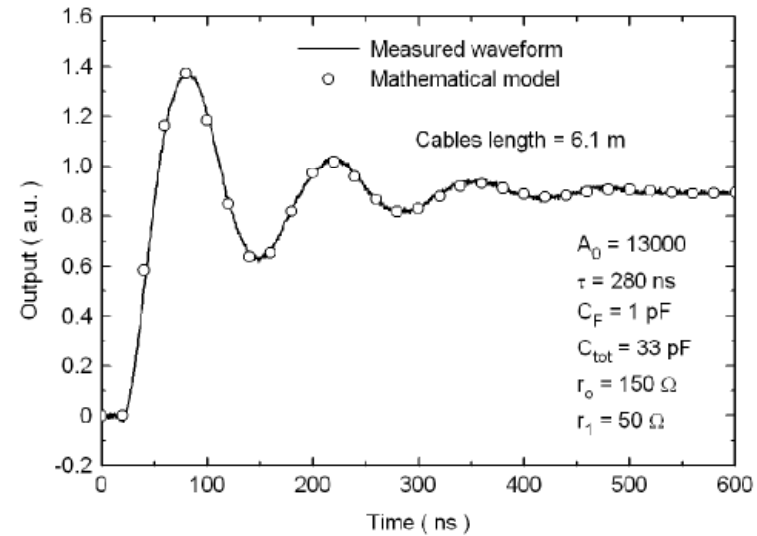
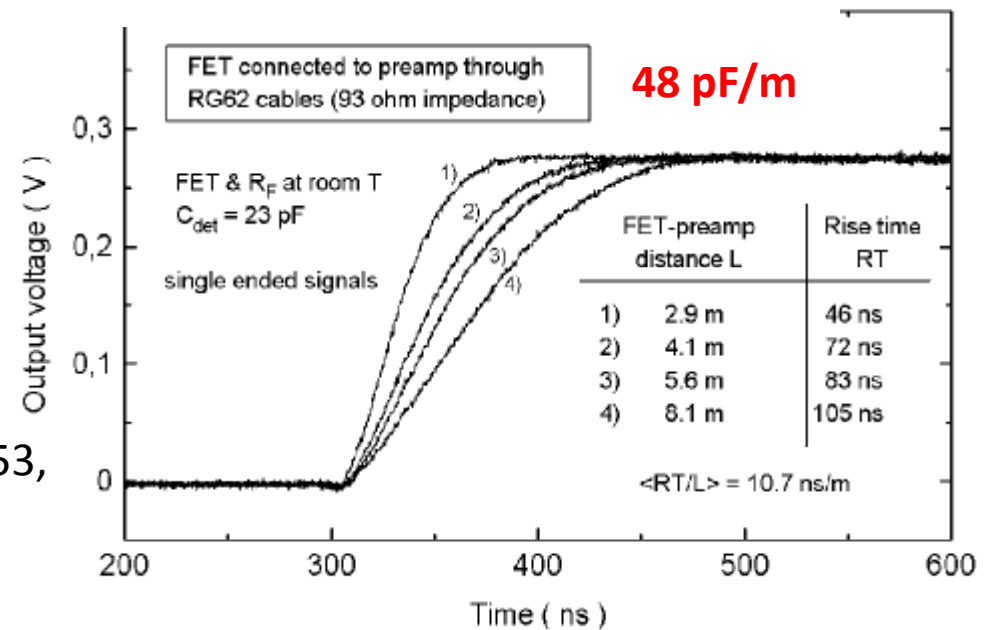

Fig. 2. Comparison between the waveform observed at the circuit output and the mathematical model in the case of a cable total length of 6.1m.



*Nuclear Science, IEEE Transactions on*, vol.53, no.3, pp.1744,1748, June 2006

Fig. 3. Output signals for different FET-preamp distances when complete compensation is made in order to eliminate any oscillation or overshoot.

# Issues related to manufacturing long (up to 80 cm) radiopure flex transmission lines

1° Find raw material radiopure, good  $\epsilon_r$ , proper thickness, cryogenic etc. → **Cuflon**

**Caveat: Polyflon can produce panels 22" maximal length.**

**33" panels came in heavily defected and with poor adhesion of Cu to Teflon layer.**

2° Find the manufacturer that can produce such long flex circuit by **controlling the radioactivity introduced in the PCB process**

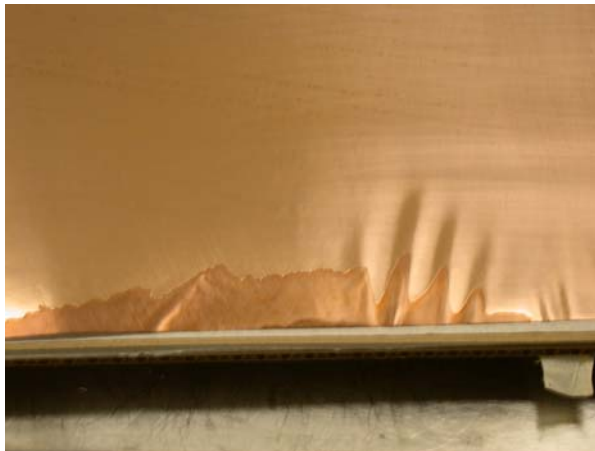



# Alternative material for long circuits: DuPont Pyralux

From ICPMS &  $\gamma$ -screening:

- once PCB processed Pyralux and Cuflon have about the same specific activity (confirmed by both ICPMS and  $\gamma$ -screening)
- **Kapton has  $(6 \pm 1)$  mBq/kg of Ra-226, not visible in ICPMS measurements, well visible in  $\gamma$ -screening**

## PYRALUX

Element	Kapton media	Cu media	Tot Cavo
Unit	ppb	ppb	ppb
Pb	100	1700	1150
Th	0.043	0.196	0.14
U	0.5	0.11	0.245

Tabella 6: contaminazione ridistribuita sull'intero cavo in base alla sua composizione.

## CUFLON

Element	Unit	Cable metallic component after lithography (84.6%)	Cable plastic component after lithography (15.4%)	Whole cable
K	ppm	<6	14	2.2<[K]<7.2
Pb	ppb	50	<30	42.3<[Pb]<46.9
Th	ppb	0.08	0.3	0.1
U	ppb	0.2	0.1	0.18

Table 5: measured K, Pb, Th and U contamination in the cable after lithography. The contributions of the different components are first shown separately, then the contamination in the whole sample is calculated. The uncertainty is about 30% of the given values. The given values are blank subtracted.

# Impact of PCB process on final FE circuits contaminations

- Once selected the proper raw material → Important not to spoil its radiopurity by PCB process.
- Avoid finishing protective layers (soldermasks etc.)
- Minimize Cu deposition
- **Gold finishing required for bonding (typically <1 um ) introduces significant U contaminations. Minimize golded surfaces (in GERDA few mm<sup>2</sup>/detector)**

				Solfor	Fosfor	Cleanin g	PreAu	Micro Etchin	Gold	Nickel
39	K	ppb		2000	4900	6100	Saturate	96000	32000000	38000
208	Pb	ppb	<	0,3	0,7	11	28	17	2	< 10
232	Th	ppb	<	0,03	0,05	< 0,03	1	0,04	1,7	< 0,3
238	<b>U</b>	<b>ppb</b>		0,13	<b>22</b>	0,8	<b>5,8</b>	0,81	<b>7,7</b>	< 0,3

		Degrease	Cu activation	Strip per	Micro- etching	Stripper Sn Pb	Sn activator	Micro- etching Sn Pb	Cu solutio	Sn E
K	ppb	4000	13000	16000	Saturato	0	4800	1100	22000	0
Pb	ppb	23	50	350	20	6600	36	11	1900	3800
Th	ppb	0.04	0.1	< 0.3	< 0.03	0.68	0.03	0.04	0.6	0.3
U	ppb	5.4	1.2	1.8	0.86	0.35	1	0.05	1.5	1

# Contaminations of FE GERDA circuits manufactured in Cuflon or Kapton substrates

	Signal (double side circuit 1 cm width) (Cuflon 3 mils)	HV (single side circuit 0.4 cm width) (Cuflon 10 mils)
Mass of FE circuit	0.5 g/10 cm	0.3 g/10 cm
U-238	1.1 uBq/10 cm	0.7 uBq/10 cm
Ra-226	<0.5 uBq/10 cm	<0.3 g/10 cm
Th-232	0.2 uBq/10 cm	0.12 uBq/10 cm

	Signal Signal (double side circuit 1 cm width) (Pyralux 3 mils)	HV (single side circuit 0.4 cm width) (Pyralux 2 mils)
Mass of FE circuit	0.5 g/10 cm	0.06 g/10 cm
U-238	1.7 uBq/10 cm	0.2 uBq/10 cm
Ra-226	3 uBq/10 cm	0.36 uBq/10 cm
Th-232	0.25 uBq/10 cm	0.034 uBq/10 cm

10 cm is the height of one detector couple.

• Thanks to its high dielectric strength (6-7 kV/mil) thin Pyralux substrates can substitute Cuflon (1 kV/mil) for single side HV flexible circuits (or for single trace readout contact for remote FE).

• The high [Ra-226] make Pyralux unsuitable for GERDA Signal (double side circuits)



# FE Ribbon cables

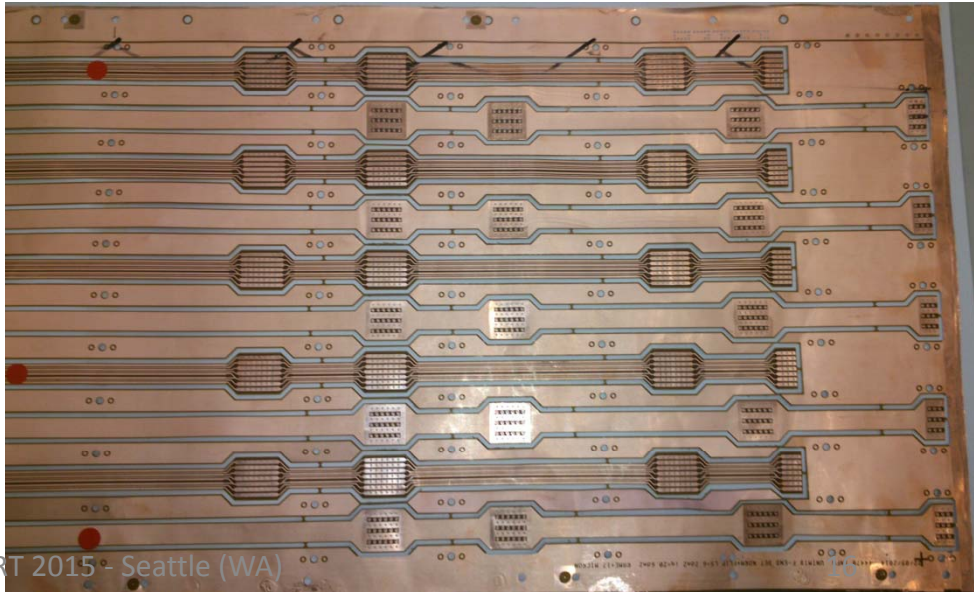
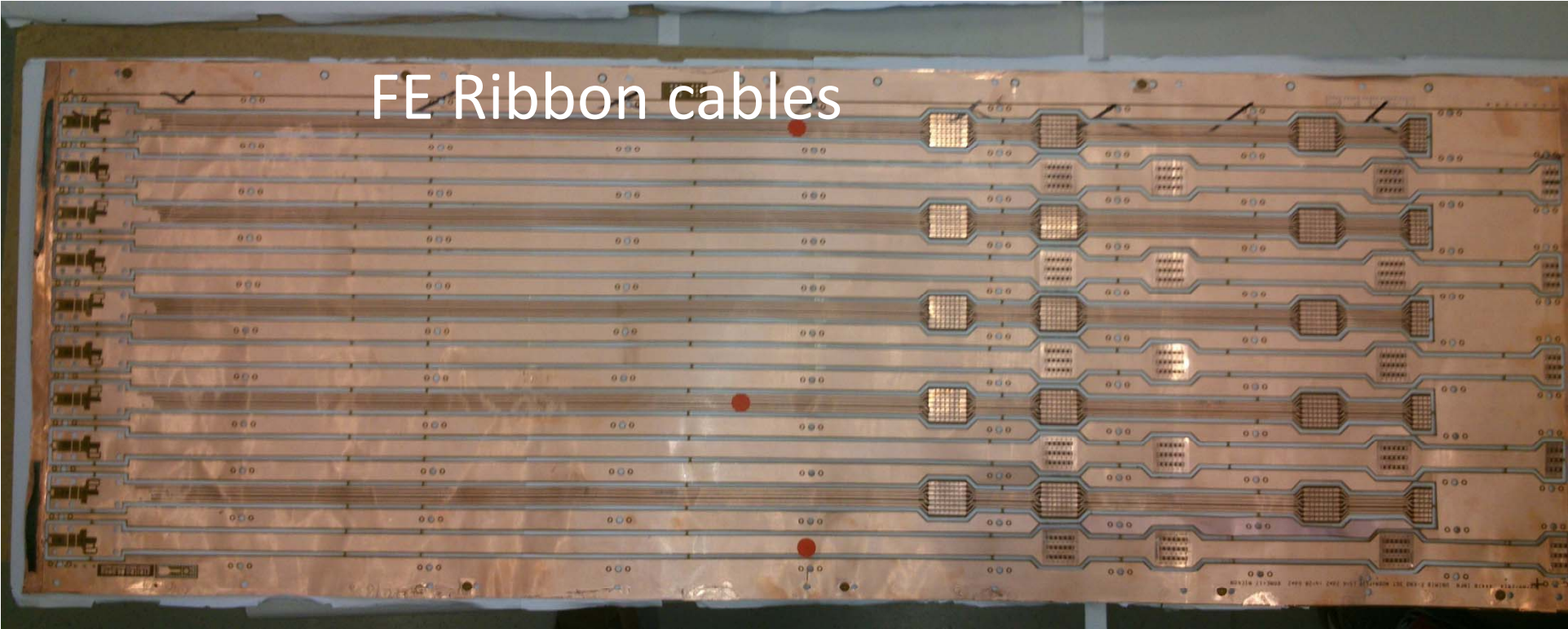

20-Mar-15

C. Cattadori - LRT 2015 - Seattle (WA)





# JFETs

So far adopted SF291 as FE JFET

Operated at  $\sim 0.5$  mA, it has a transconductance of 5 mA/V and the gate voltage is negative

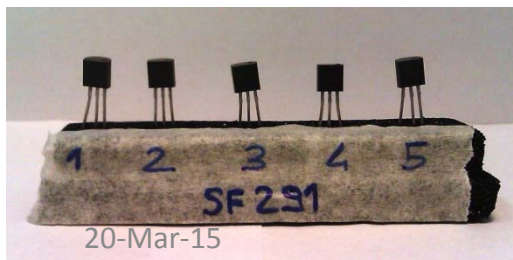
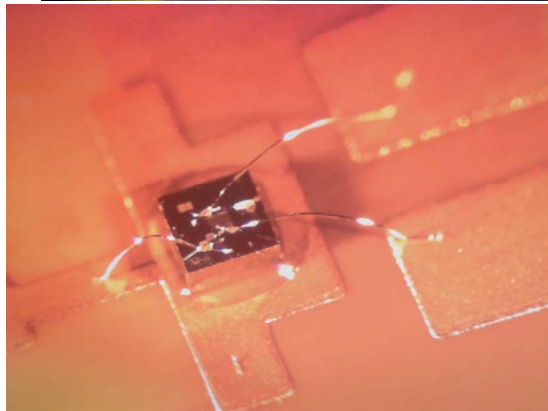
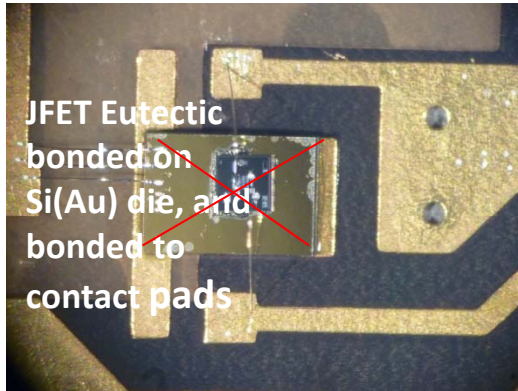

## PRO

- ✓ Noise OK
- ✓  $g_m$  OK
- ✓  $C_{in}$  OK
- ✓ Activity OK
- ✓ Comes in die

## CONS

- no top gate contact (solved)
- negative  $V_{GS} \rightarrow$  no possible to protect the device by diode reverse pol mounting

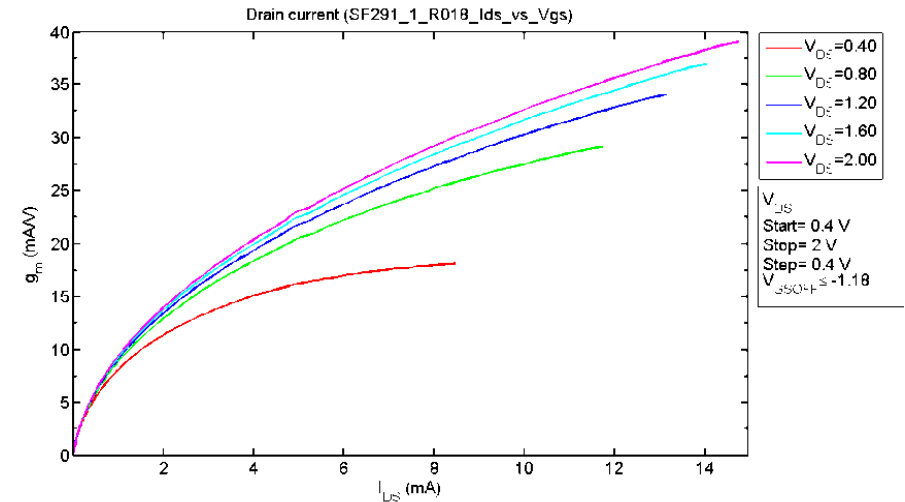

		JFET uBq/pc $\gamma$ -screen	Araldite uBq (5mg)
Th-232	Ra-228	< 2.2	$2 \times 10^{-3}$ (30%)
	Th-228	< 4.5	
U-238	Ra-226	$1.3 \pm 0.4$	$2 \times 10^{-3}$ (30%)
	Th-234	< 16	
	Pa-234m	< 58	

# Feedback R: present choice SMD miniaturized (500 MOhm)

Size	Th-234 [uBq/pc]	Ra-226 [uBq/pc]	Th-228 [uBq/pc]	K-40 [uBq/pc]	Pb-210 [uBq/pc]
0603 0.48 mm <sup>3</sup> /pc 1.33 mg	4 ± 2	1.9 ± 0.3	0.6 ± 0.2	10 ± 4	46 ± 5
0402 0.153 mm <sup>3</sup> /pc 0.6 mg/pc	2 ± 1	0.7 ± 0.1	0.2 ± 0.1	< 2.6	32 ± 3
<b>BI no veto</b>		<b>4.1E-4</b>	<b>1.7E-4</b>		
<b>BI w. veto</b>		<b>3.4E-5</b>	<b>3.4E-7</b>		

**R&D on custom R (0.5-1.0) GOhm:**

- Amorph Ge
- TiN
- Gold or W

**Deposited on quartz substrates ongoing**



Th & Ra scale with Volume as expected

K lower than expected

Pb-210 doesn't scale with volume → probably from the contact pads

The activity of the R in 0402 size is within the expected activity of the Signal Flex cable



# Test of FE flexes at MiB



20-Mar-15

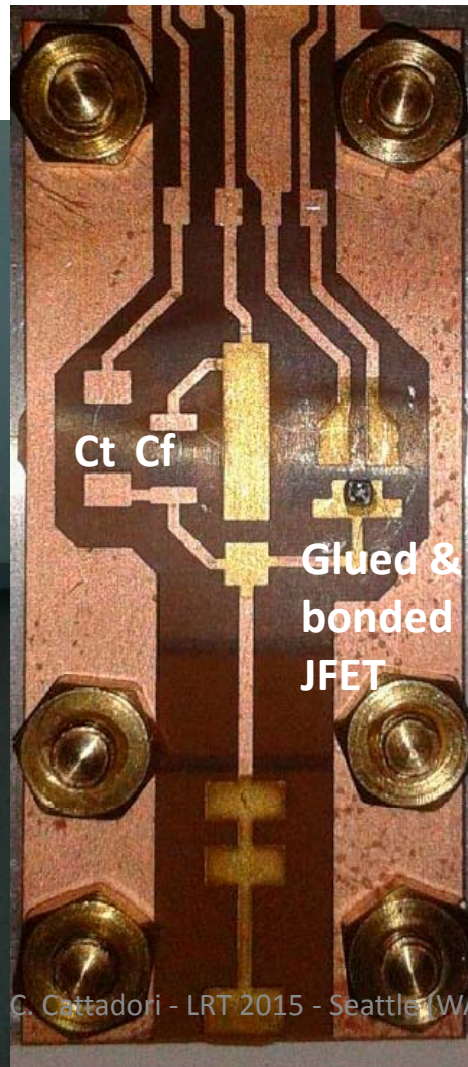

C. Cattadori - LRT 2015 - Seattle (WA)



20



# Signals from GERDA II FE Ribbon Cables & CC3

Inserire forma d'onda vera segnale BEGe

- CC3
- FE Kapton & Cufion Ribbon cables
- die JFETs
- Rf=500 Mohm SMD (0402 size )

Achieved

- RT < 100 ns
- OK for BEGe PSD

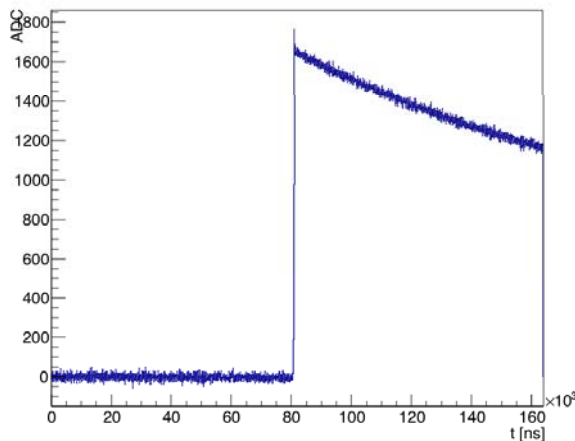
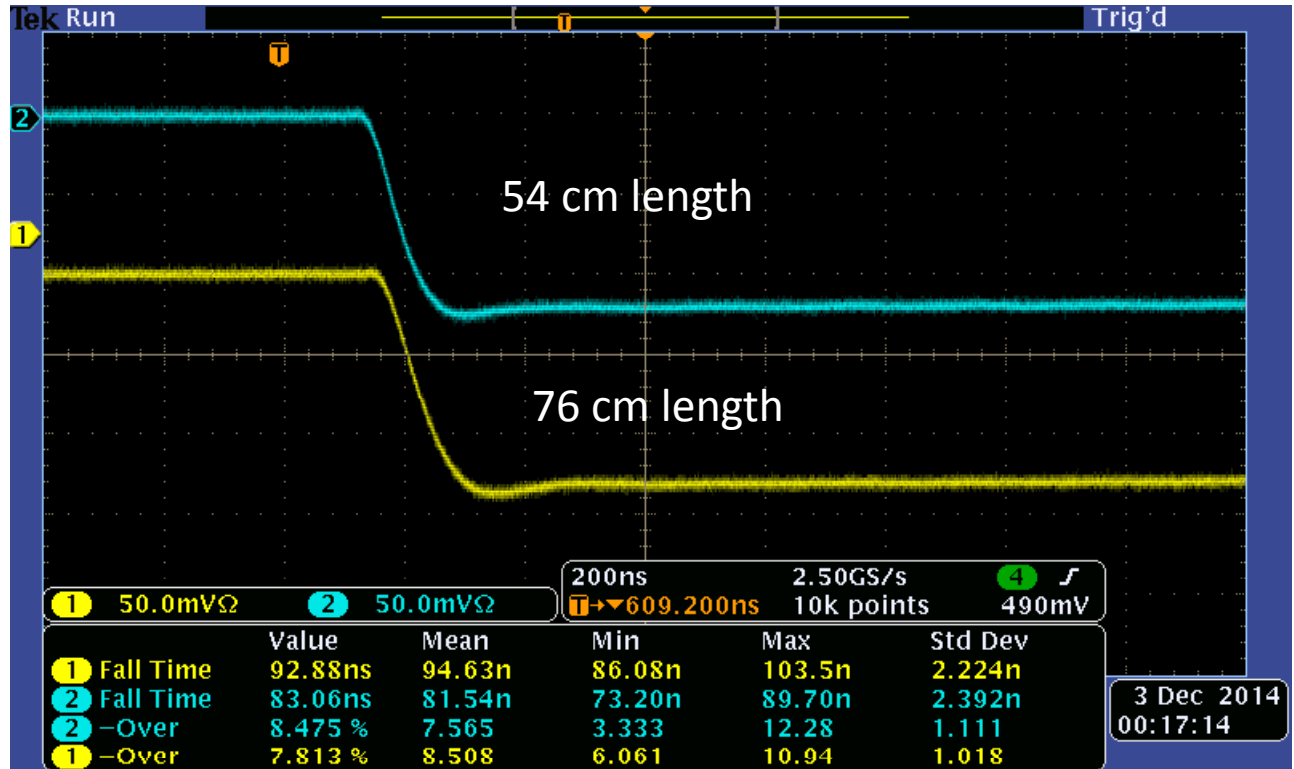

# Performances achieved in GERDA Commissioning Run

Spectrum Ch 1 - 3/D

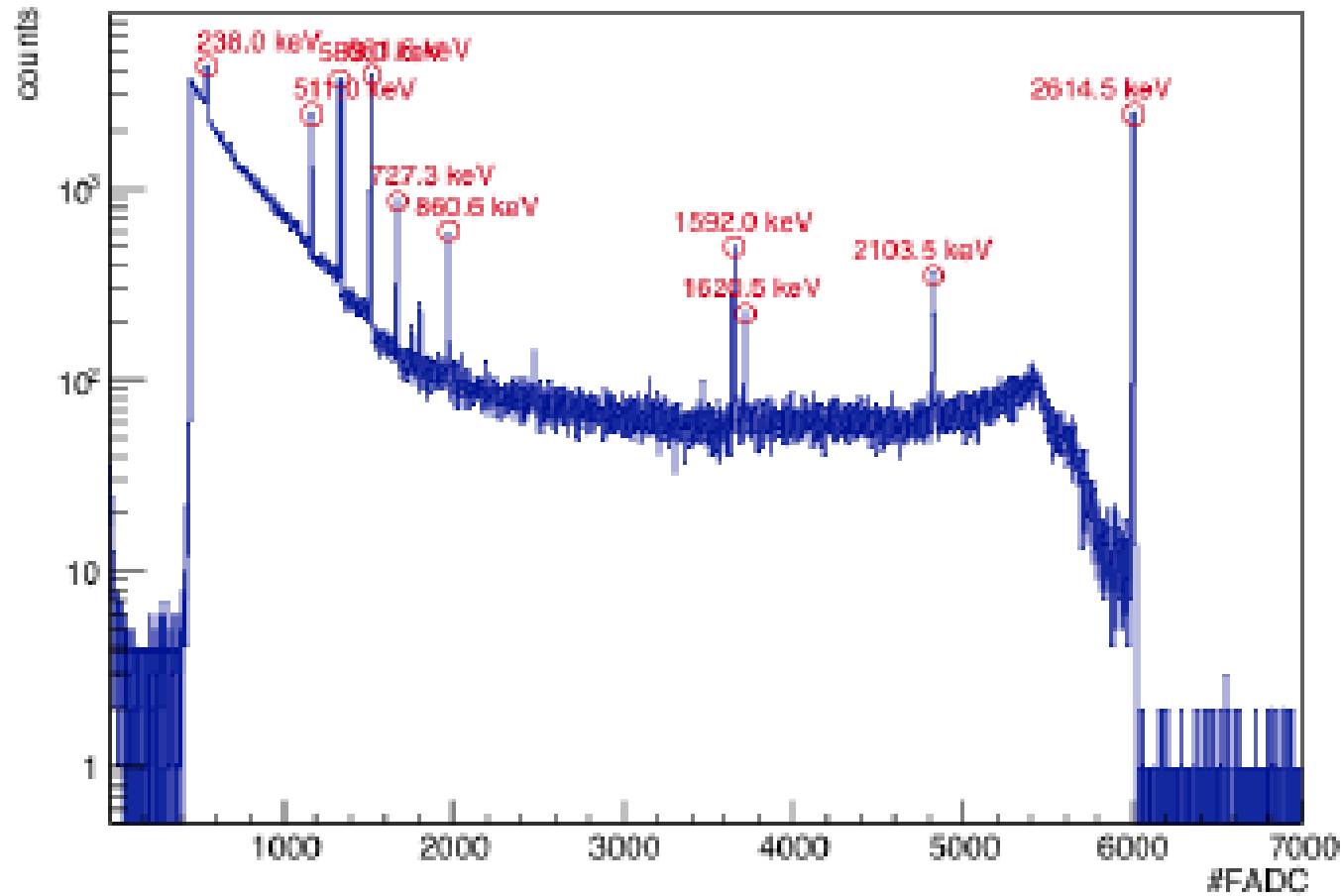

# Ch 2 - 2/B

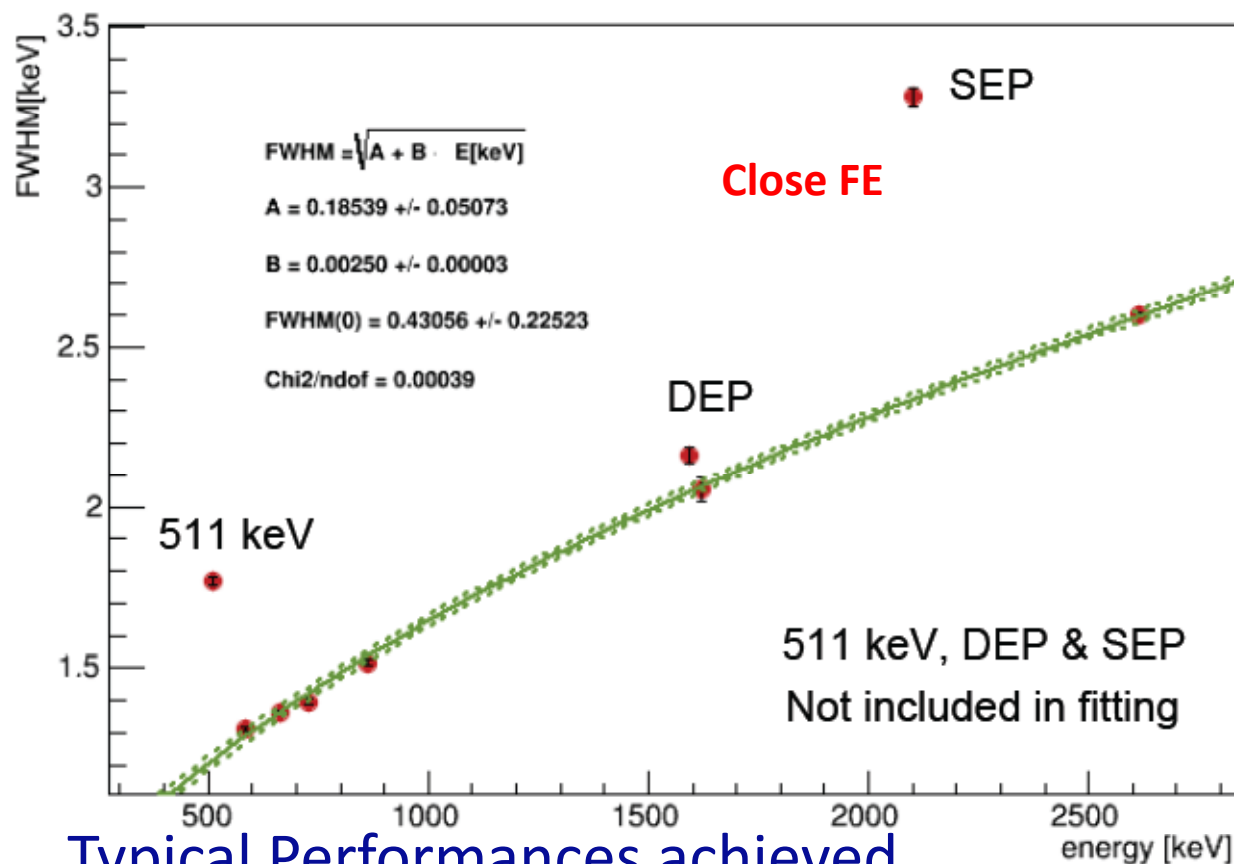

Typical Performances achieved  
in GERDA Commissioning run

Detector	ZAC		Gaussian	
	FWHM(o) [keV]	B [eV]	FWHM(o) [keV]	B [eV]
Close FE	0.43 ± 0.22	2.50 ± 0.03	1.3 ± 0.3	2.3 ± 0.1
Far FE	1.31 ± 0.39	2.61 ± 0.10	1.8 ± 0.3	3.0 ± 0.1

$$B_{\text{stat}} = 2.35^2 \times 2.96 \text{ eV} \times 0.13 = 2.13 \text{ eV}$$

- LRT 2015

Close FE	Jan 2015	Feb 2014
Peak [keV]	FWHM [keV]	FWHM [keV]
583	1.76 ± 0.01	1.50(0)
DEP	2.50 ± 0.03	2.14(2)
1620	2.30 ± 0.05	2.12(3)
SEP	3.54 ± 0.05	3.32(3)
2614.5	2.80 ± 0.01	2.71(1)

# Linearity of the energy scale in GERDA II Commissioning

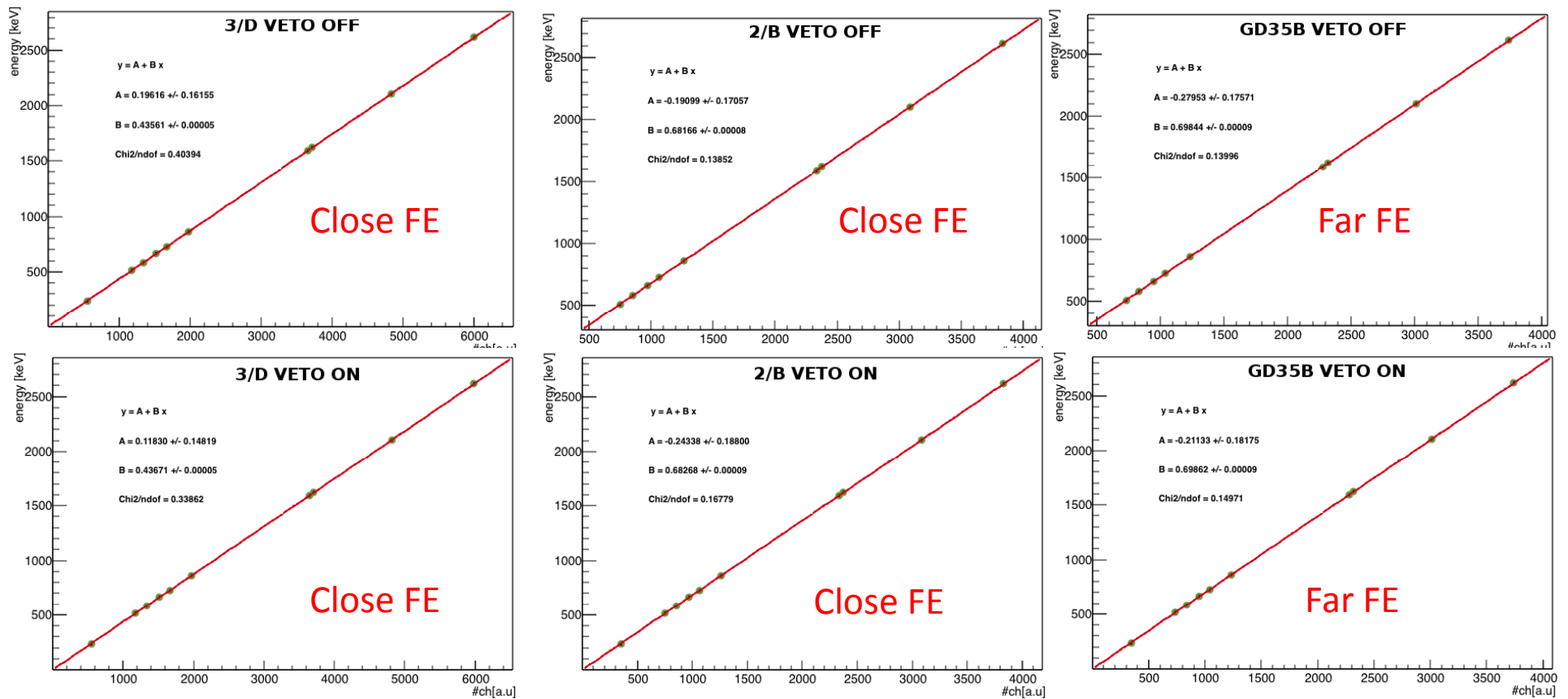

- Linearity during January 2015 commissioning run
- Comparison of VETO ON vs VETO OFF: no visible variation of gain



# Typical survival fractions after pulse shape discrimination in GERDA II Commissioning.

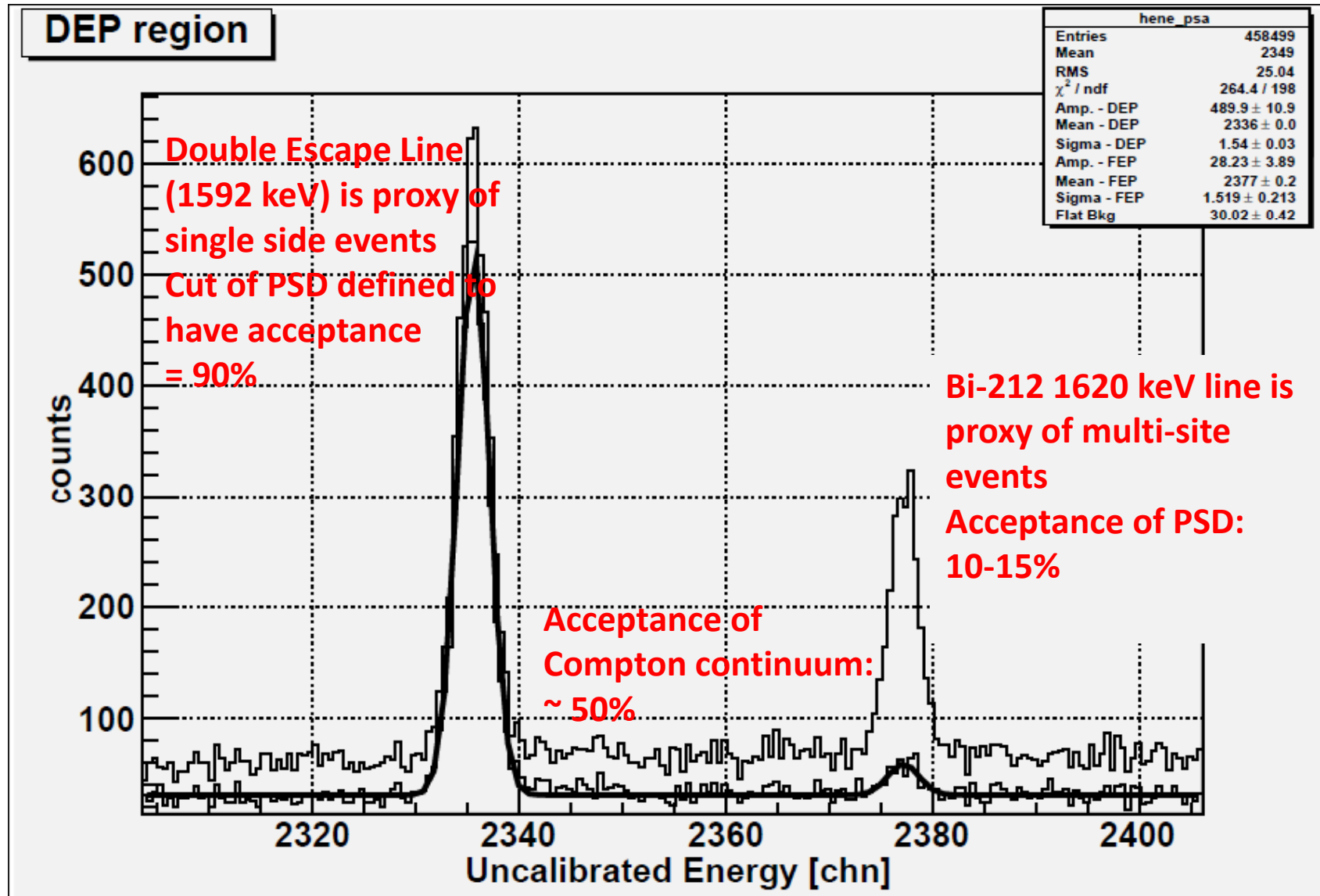

# Stability of 2/B from 06.02.2015 - VETO ON

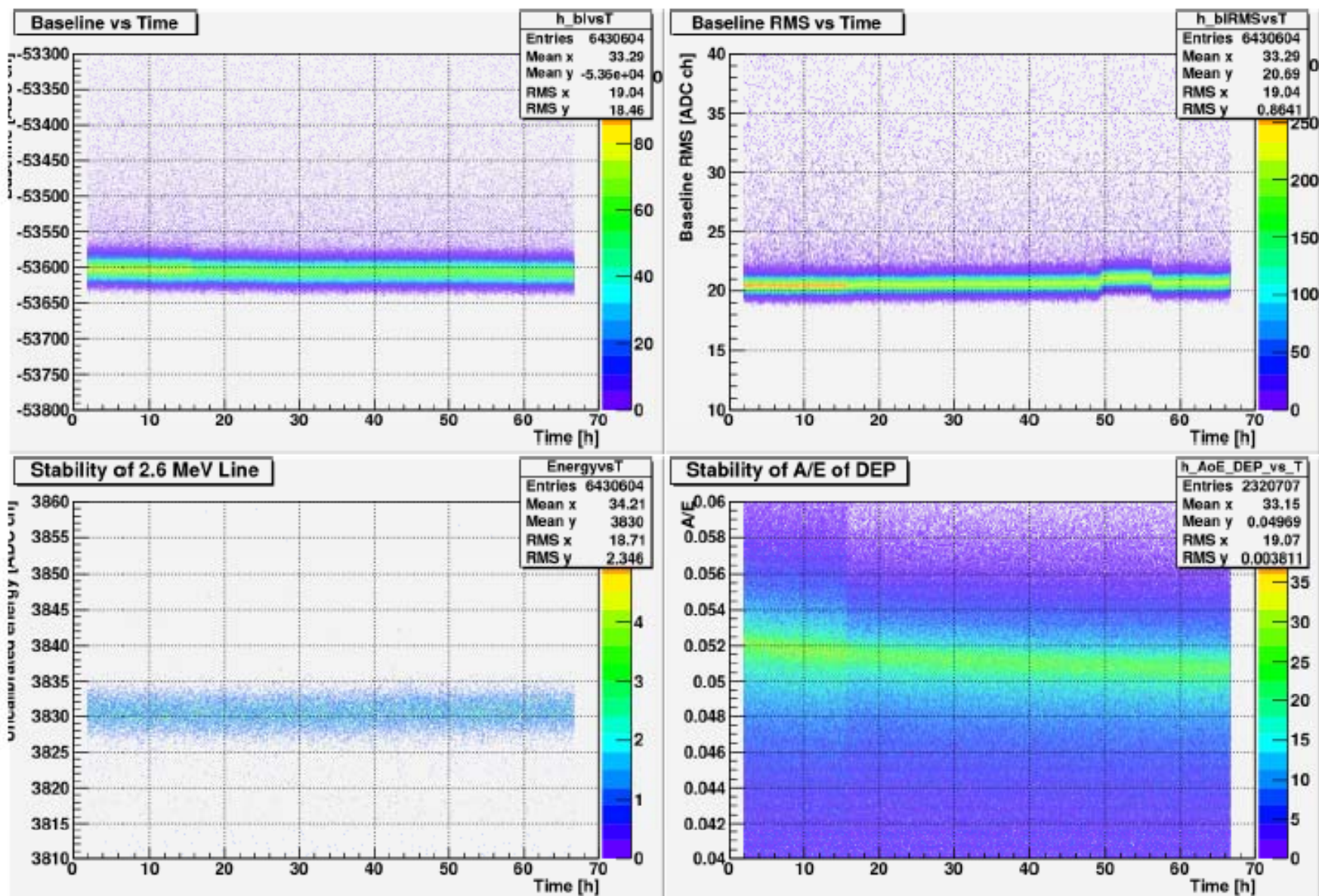

# Flex circuit conformal coating: Parylene deposition system available @ LNGS

The PDS 2010 transforms Parylene dimer to a gaseous monomer; upon deposition the material polymerizes, at room temperature, onto the substrate. There is no intermediate liquid phase or separate cure cycle. At the vacuum levels employed, all sides of the substrate are uniformly impinged by the gaseous monomer, resulting in a truly conformal coating.

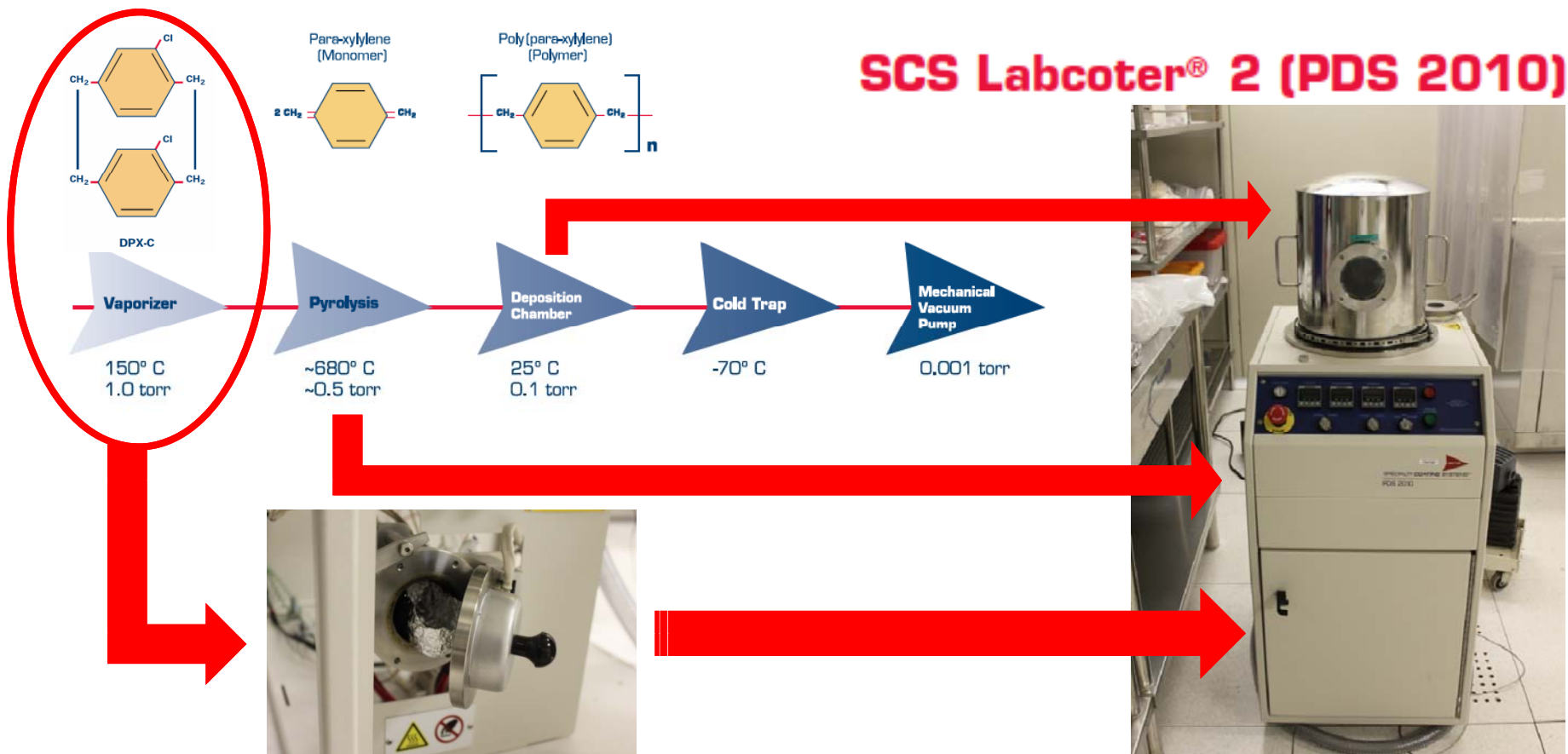



# Parylene coating of GERDA flex

- 1) Masking is necessary to avoid electric contact insulation by parylene deposition.
- 2) Samples to be coated suspended into the vacuum deposition chamber (30 cm diameter x 30 cm height):

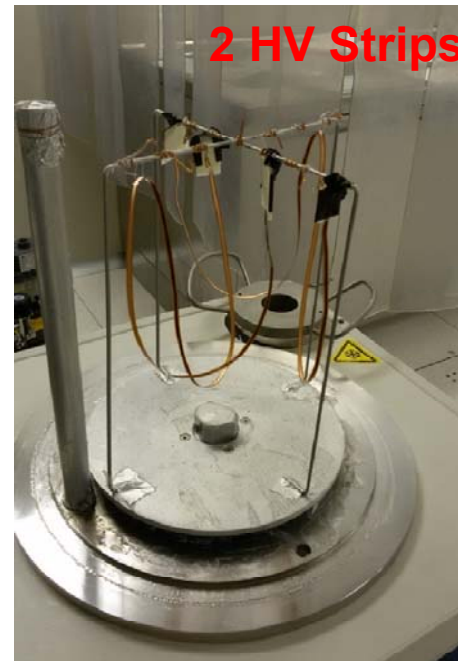
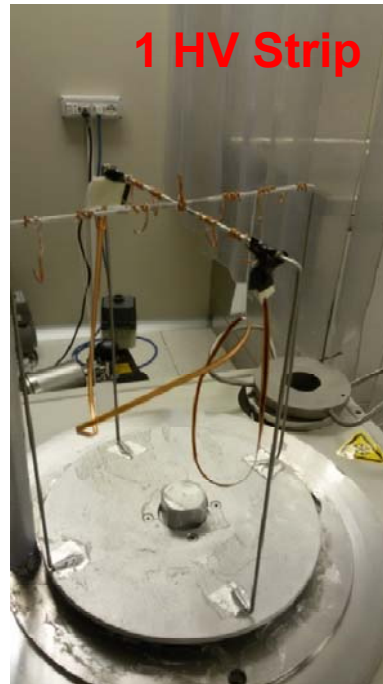
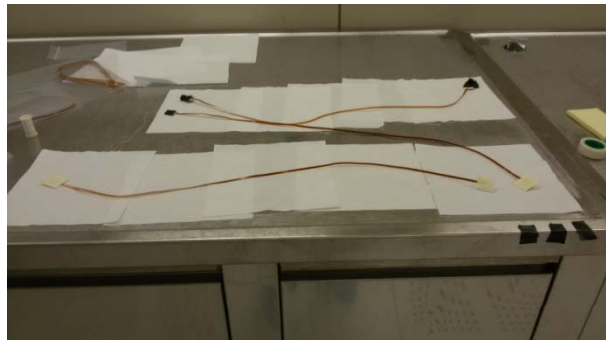
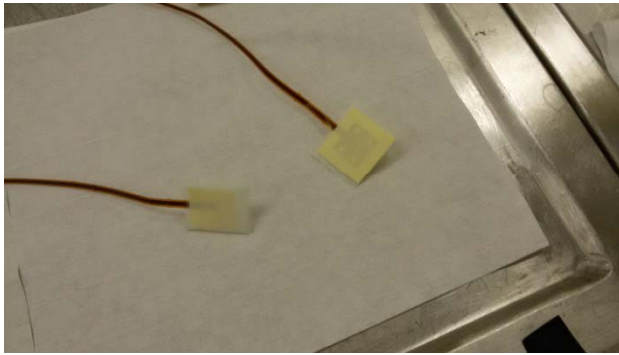

Coating thickness is controlled mainly by the amount of dimer:  
 **$\approx 20$  g Parylene C** for  **$\approx 30$   $\mu\text{m}$**  coating in 5 hour deposition



# Radiopurity of Parylene C

ICP-MS measurement @ LNGS:

	Th	U	K	Pb
GALXYL C	< 40 ppt ( $<1.62 \cdot 10^{-7}$ Bq/g)	< 20 ppt ( $<2.45 \cdot 10^{-7}$ Bq/g)	< 200 ppb ( $<26$ Bq/g)	< 2 ppb

For example

1 GERDA Ph II unit = 2 BEGEs

4 GERDA Ph II units → 8 signal FLEXs

## Estimated contamination due to 8 signal (or HV) cables

$^{232}\text{Th}$ : 10  $\mu\text{m}$  coating →  $<0.132 \mu\text{Bq}$

50  $\mu\text{m}$  coating →  $<0.664 \mu\text{Bq}$

$^{238}\text{U}$ : 10  $\mu\text{m}$  coating →  $<0.2 \mu\text{Bq}$

50  $\mu\text{m}$  coating →  $<1 \mu\text{Bq}$

$^{40}\text{K}$ : 10  $\mu\text{m}$  coating →  $<0.21 \mu\text{Bq}$

50  $\mu\text{m}$  coating →  $<0.105 \mu\text{Bq}$

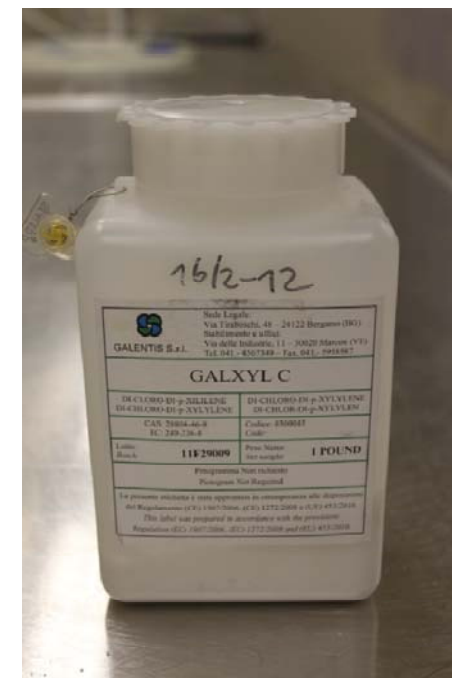



# Conclusions

- In the framework of the GERDA setup upgrade to the Phase II, the Ge-FE electronic has been upgraded to better match the Phase II detector features with the aim of preserving the Ge signals (54 fC for 1 MeV released in Ge) from HF and LF disturbances and minimizing the intrinsic noise related to long capacitive lines
- Designed and manufactured flex circuits to contact, by wire bonding the Ge detectors and to act as substrates for the FE devices (JFET in die) and coplanar waveguides
- Results achieved are OK in term of Energy
  - (FWHM < 3 keV @ 2614 keV) and Pulse Shape analysis ,
  - not yet satisfactory in term of reliability of JFET survival fraction → GERDA PHASE II will start with still far away front end devices
- Huge and systematic effort selecting the FE components (JFETs, SMD Resistors) and qualifying the PCB process has been done in collaboration with the LNGS facilities. This to reach GERDA Phase II design background index of  $10^{-3}$  cts/(keV kg y) at  $Q_{\beta\beta}$  (2039 keV).

# EXTRA SLIDES



## Total activity of last 1 m cable closest to detectors

- Assuming 300 cables (100 each type), last 1 m of cable will account for a total activity of 1.5 mBq.
- Rn emanation on the woven bands < detectable limits (10  $\mu$ Bq)
- Thanks to high quality material outgassing  $10^{-6}$  mbar l/sec after 24 pumping time

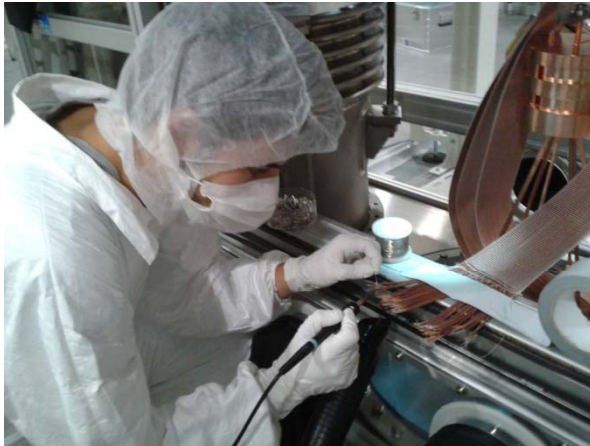

20-Mar-15



C. Cattado

# Potting the HV FeedThroughs with Blue Stycast to prevent arch effect of the HV biased surfaces operated in Ar atmosphere

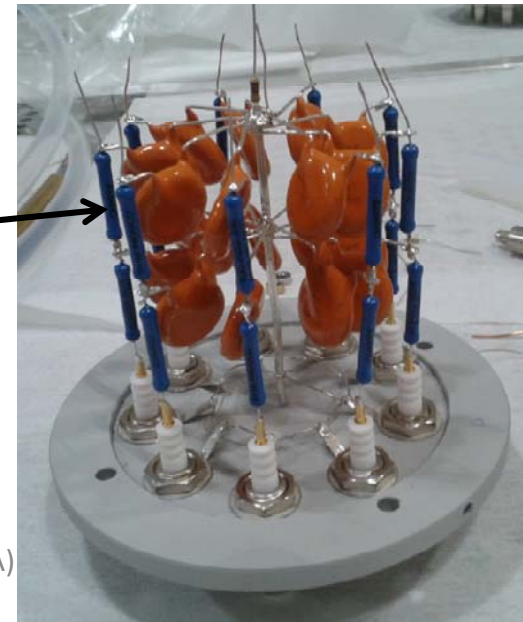
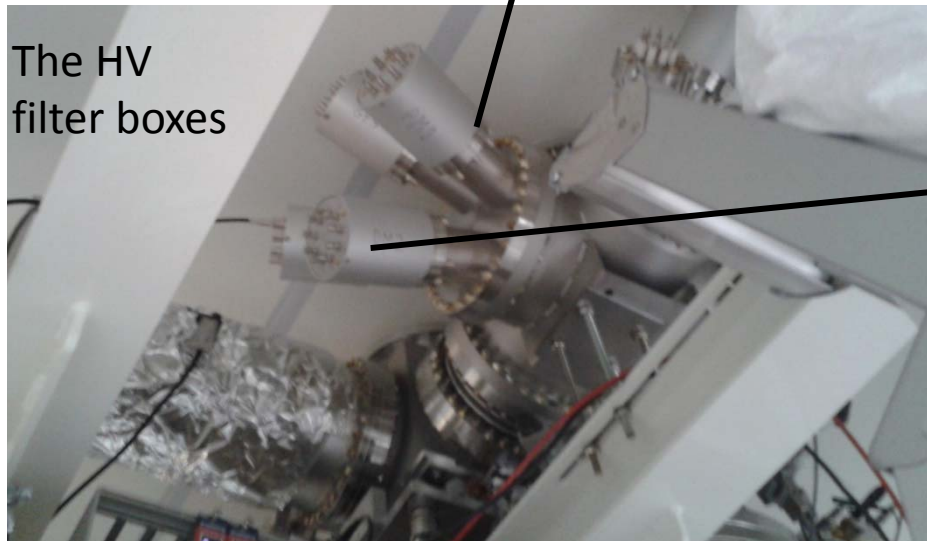
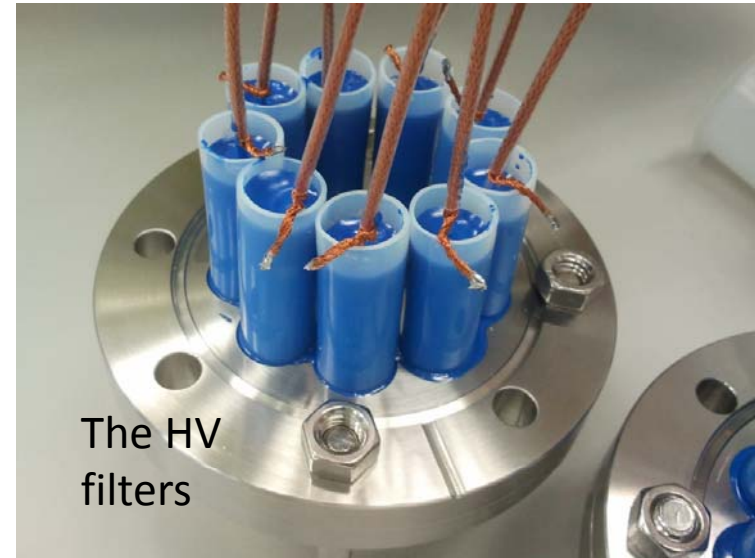
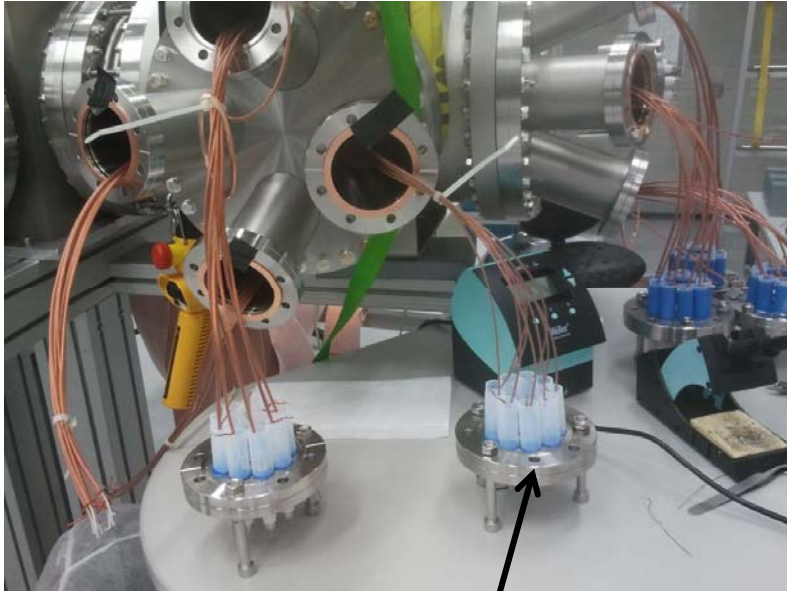

2015 - Seattle (WA)



PCB to  
interconnect  
CC3 to Coax  
cables

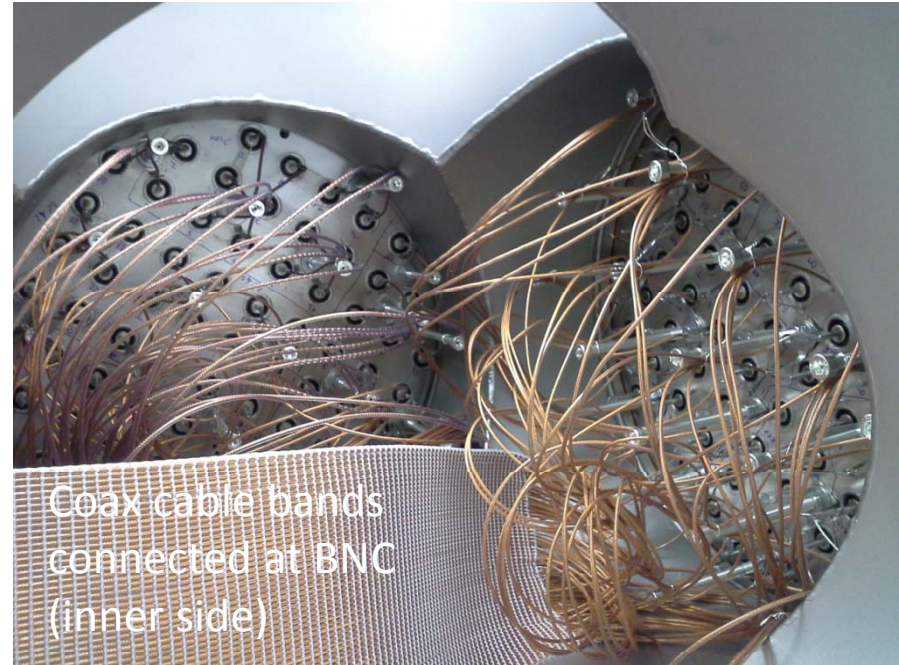
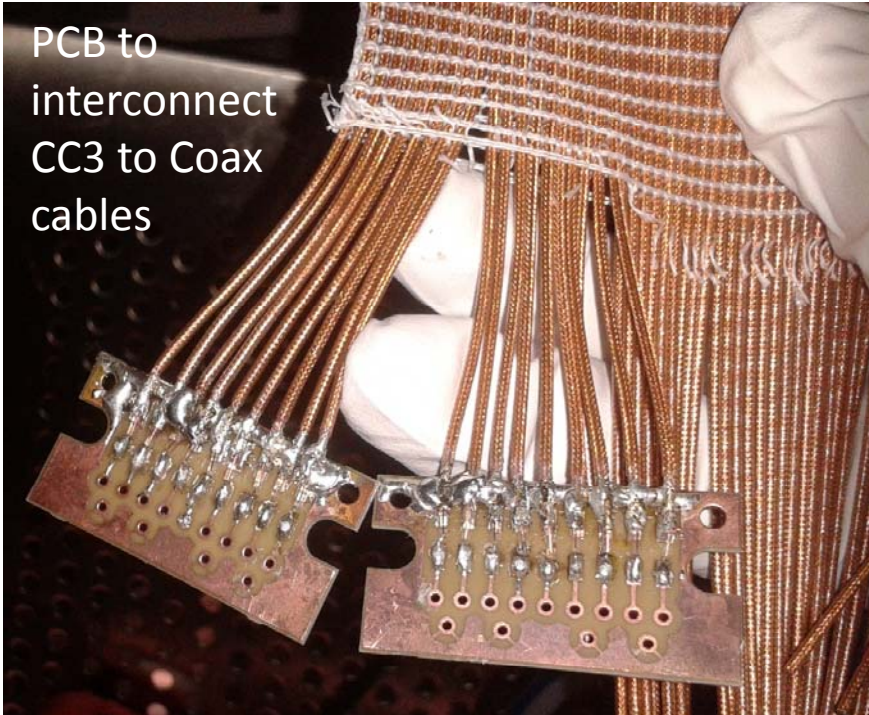

Coax cable bands  
connected at BNC  
(inner side)

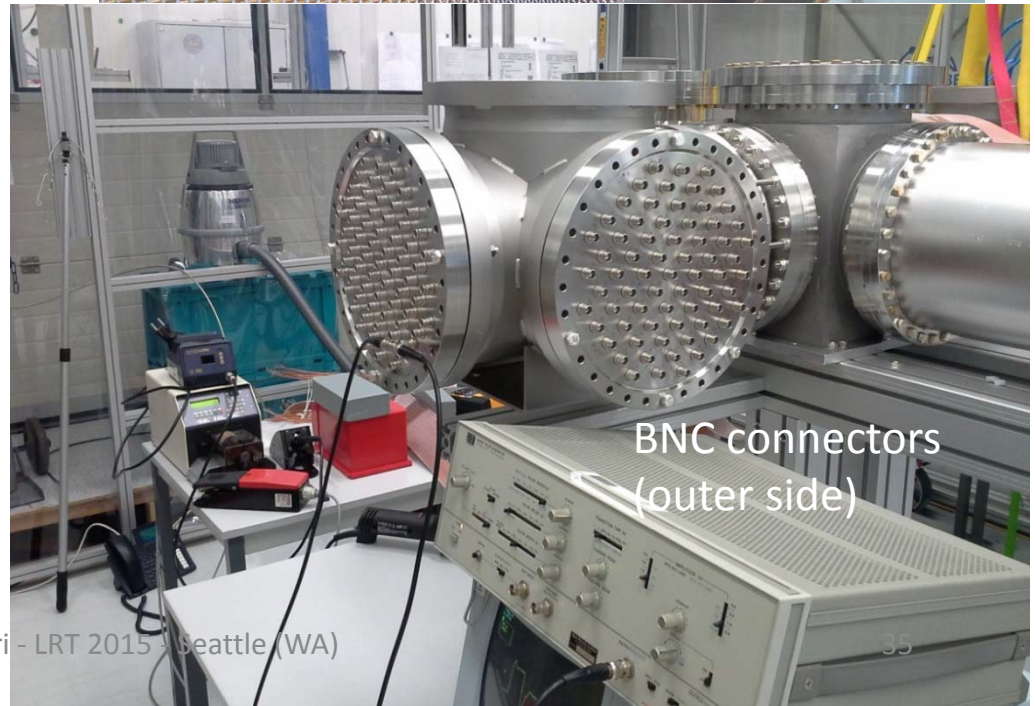
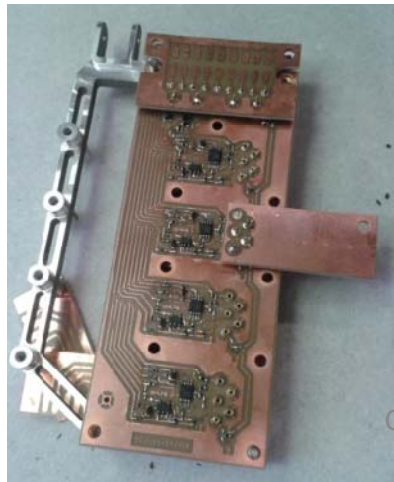

BNC connectors  
(outer side)

20-Mar-15

C. Cattadori - LRT 2015 - Seattle (WA)

35



# Signal & HV coaxial cable ends preparation

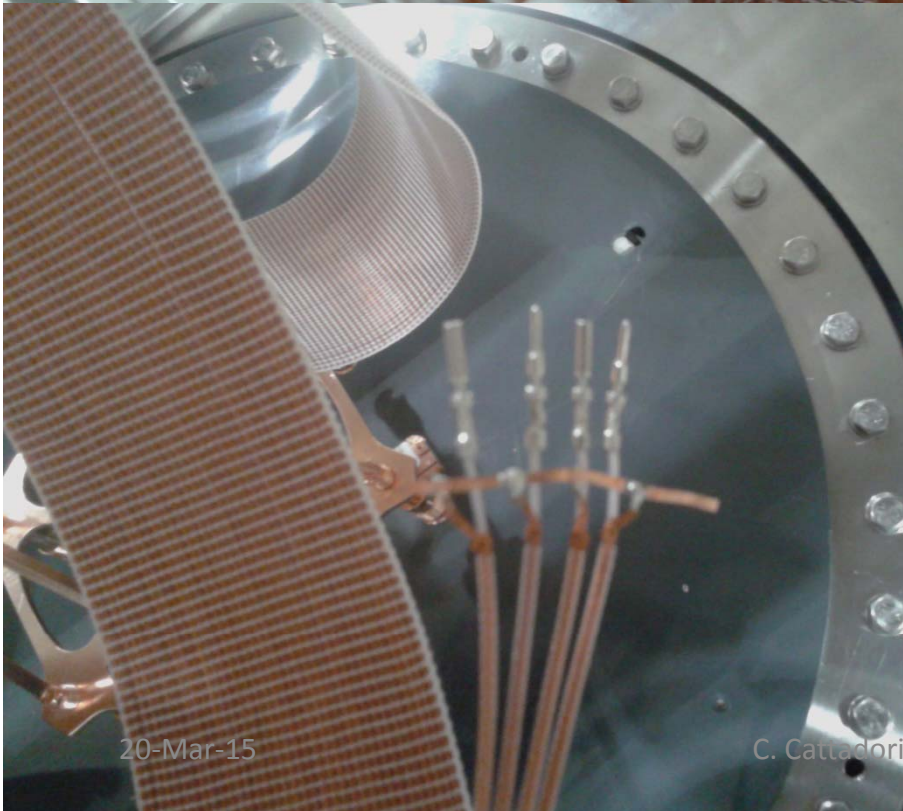

20-Mar-15

C. Cattadori - LRT 2015 - Seattle (WA)

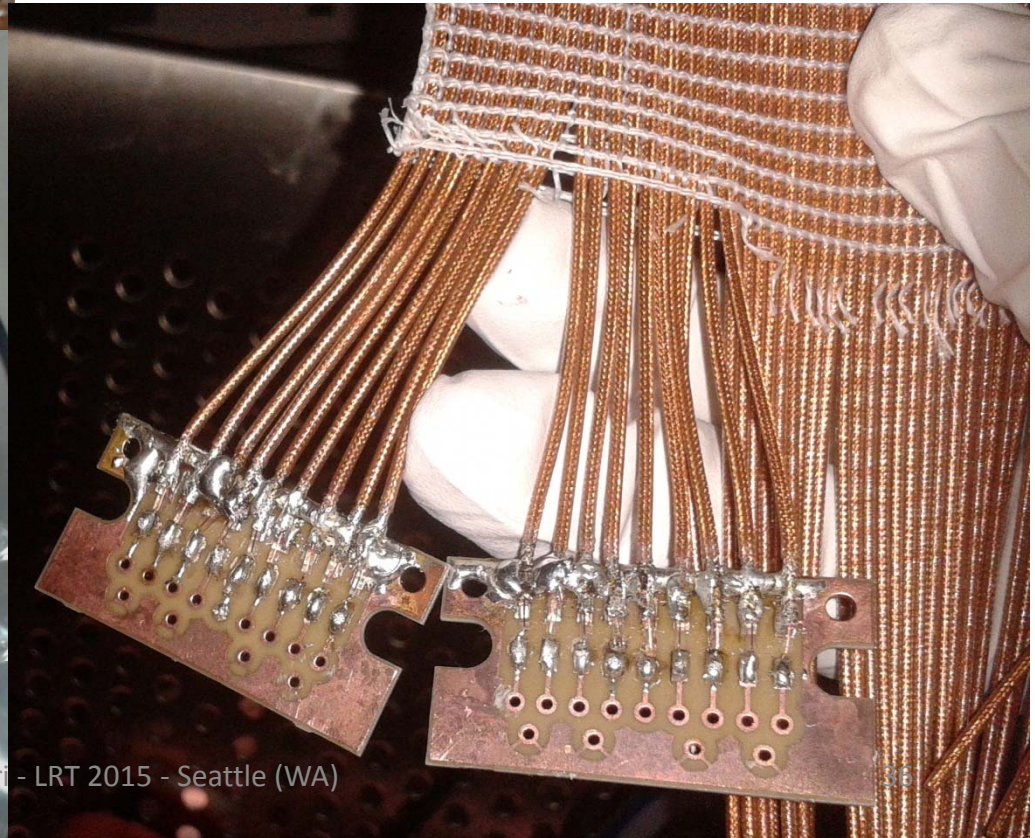



# Data from: GDL Run 14/06/2014

Energy [keV]	FWHM [keV]
238	1.142+/-0.022
538	1.349 +/- 0.016
DEP 1592.5	2.175 +/- 0.027
FEP 1620.6	2.178 +/- 0.074
SEP	3.189 +/- 0.053
FEP 2614.5	2.544 +/- 0.031
Pulser	0.94

- **Optimized modified butterfly (ZAC) filter**
- Fitting function: gaus+gaus + pol0
- FWHM= DEP → (2.175 +/- 0.027) keV  
FEP → (2.178 +/- 0.074) keV
- Cross-Talk: ~ 1% or larger depending on load, gndind etc. : work ongoing

