

# GERDA Collaboration-Meeting

LNGS, ITALIEN 28.09.09 – 30.09.09



## *Status of the PLC*

*temporary and final lock*

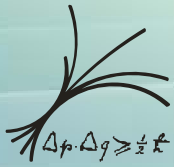

# Outlook

## ***PLC (temp. lock)***

- ***Installation***
- ***operation in operator mode***
- ***operation in maintenance mode***
- ***List of known problems***
- ***Security issues***

## ***PLC (final lock)***

- ***Status***

## ***Summary***

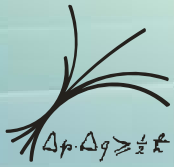

# *Installation*

- installation of the PLC in Hall di montaggio is completed (for one cable arm)
- three pressure sensors (absolut and differential)
- one shutter connected
  - cryo-shutter and pump-shutter are set to open/closed (interlocks)
- pump system
- one video camera to monitor the movement of the energy-chain
- one web cam to monitor the cable drum and the stainless steel rope

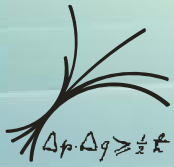

# PLC Overview

SIEMENS

SIMATIC PANEL

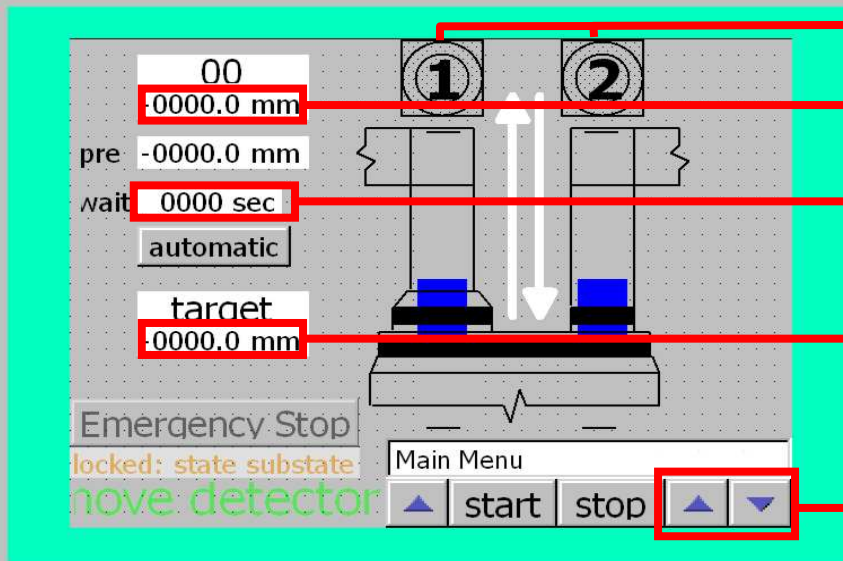

**String selector**

**Current position display**

**Target position display**

**Precondition**

**Scroll u/d motor programs**

**Motor program syntax e.g. +900 – GoTo MTRailSys**

Current position [mm]

And what to do ?

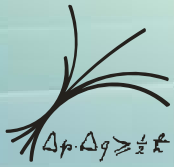

# Operator mode

Max-Planck-Institut für Physik  
(Werner-Heisenberg-Institut)

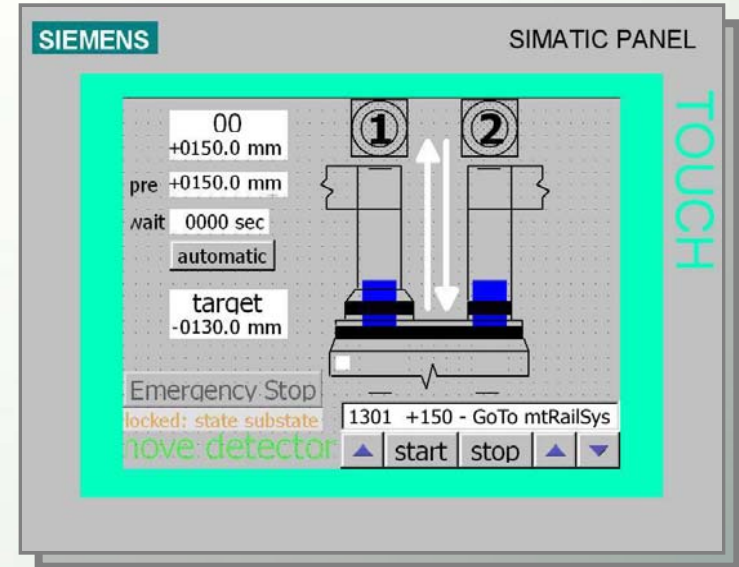
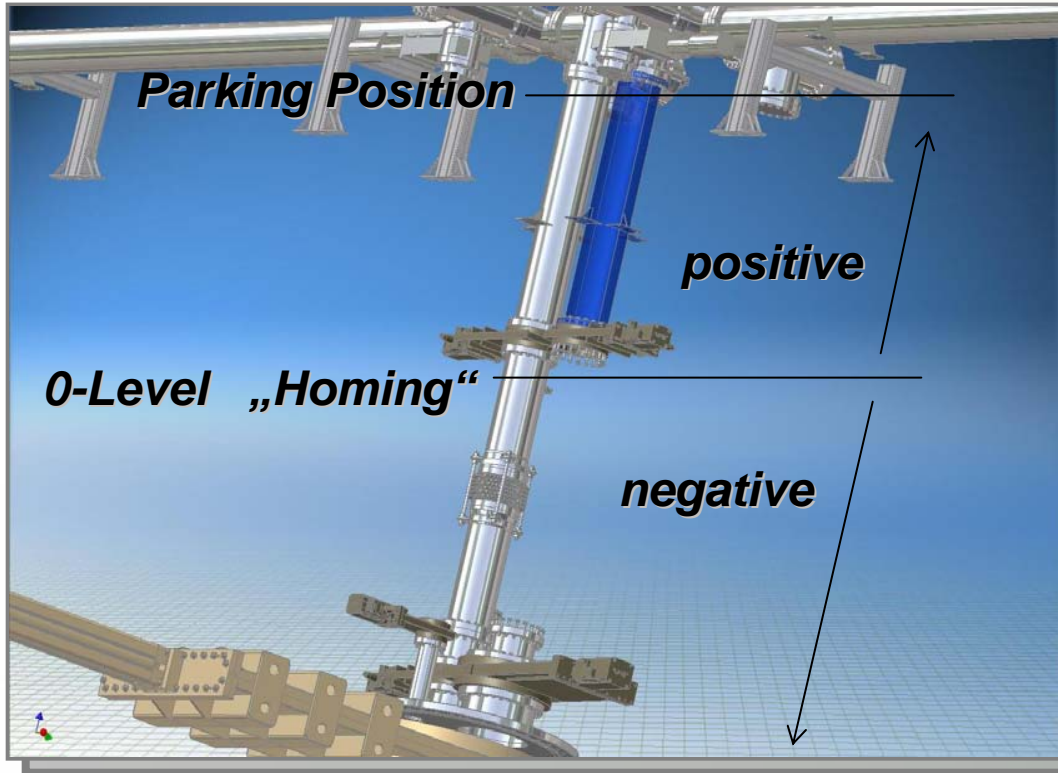

- **+150 – GoTo - mtRailSys**
- 130 – Auto – (un)mt String**
- +20 – GoTo – unmt RailSys**
- 150 – GoTo - parking position**
- +900 – Auto - imerge string LAr**
- 6000 – GoTo - parking position**

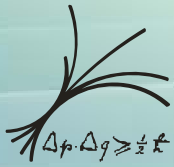

# Operator mode

Max-Planck-Institut für Physik  
(Werner-Heisenberg-Institut)

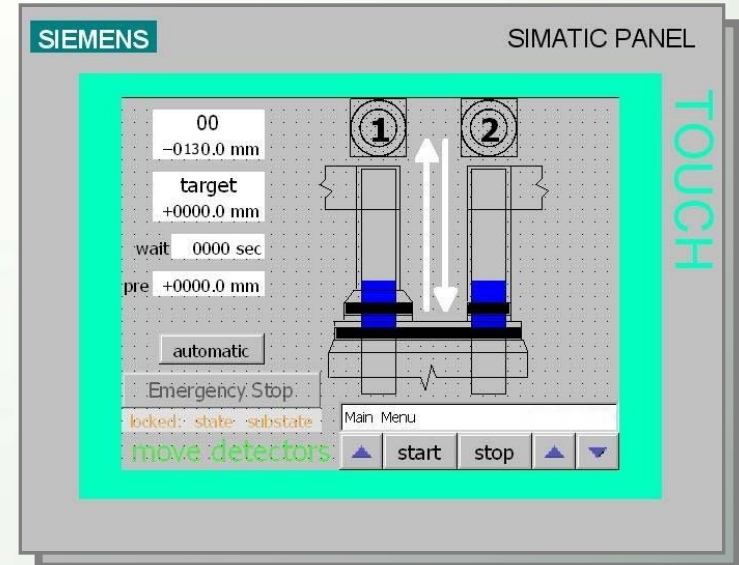
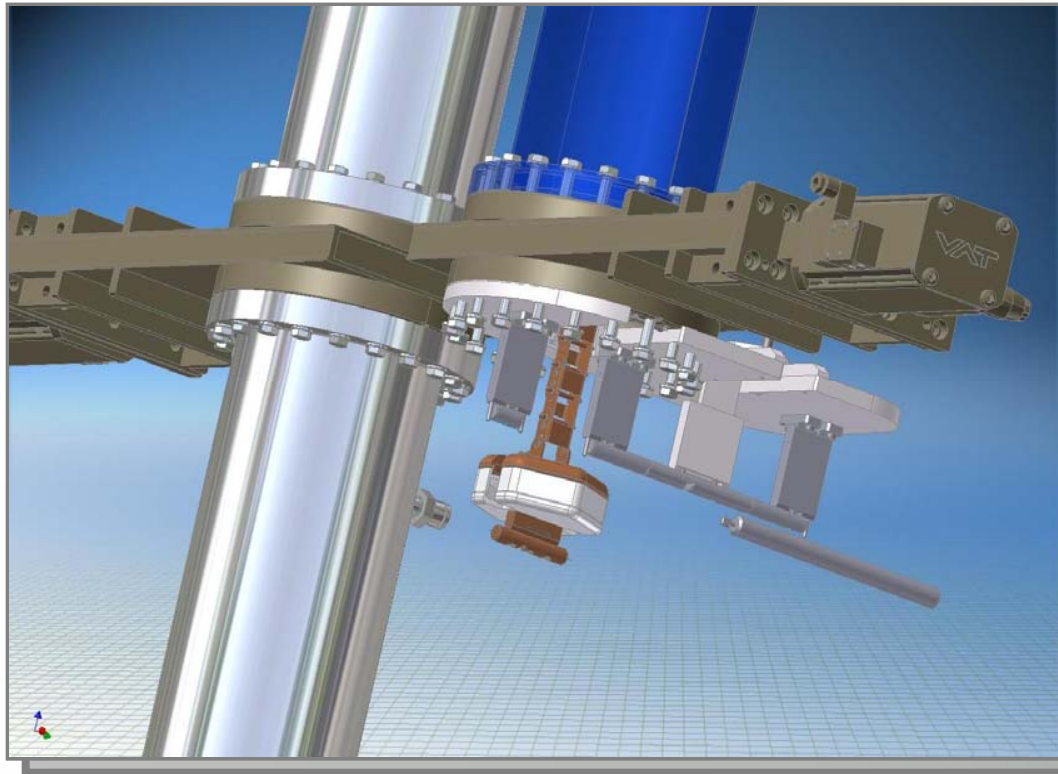

**+150 – GoTo - mtRailSys**

→ **-130 – Auto – (un)mt String**

**+20 – GoTo – unmt RailSys**

**-150 – GoTo - parking position**

**+900 – Auto - imerge string LAr**

**-6000 – GoTo - parking position**

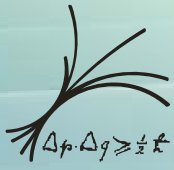

# Operator mode

Max-Planck-Institut für Physik  
(Werner-Heisenberg-Institut)

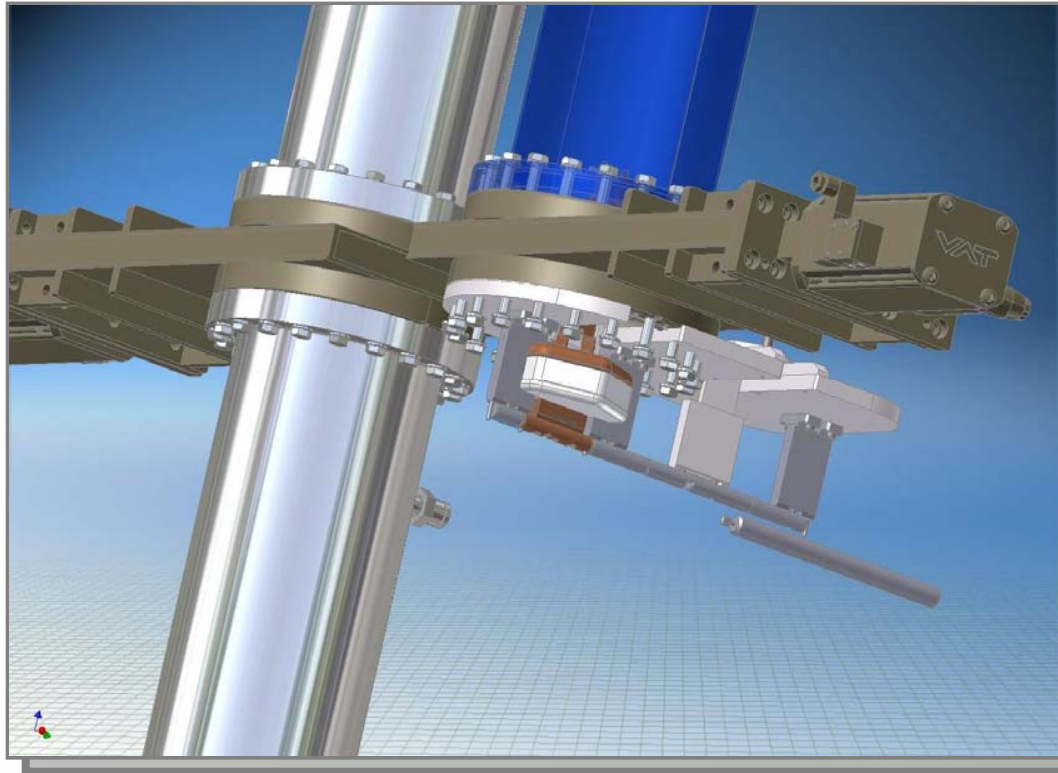

SIEMENS SIMATIC PANEL

TOUCH

00	-0000.0 mm
target	+0000.0 mm
wait	0000 sec
pre	+0000.0 mm

automatic

Emergency Stop:

locked: state substate

move detectors

Main Menu

start stop

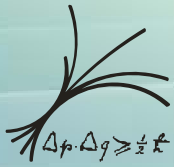

# Operator mode

Max-Planck-Institut für Physik  
(Werner-Heisenberg-Institut)

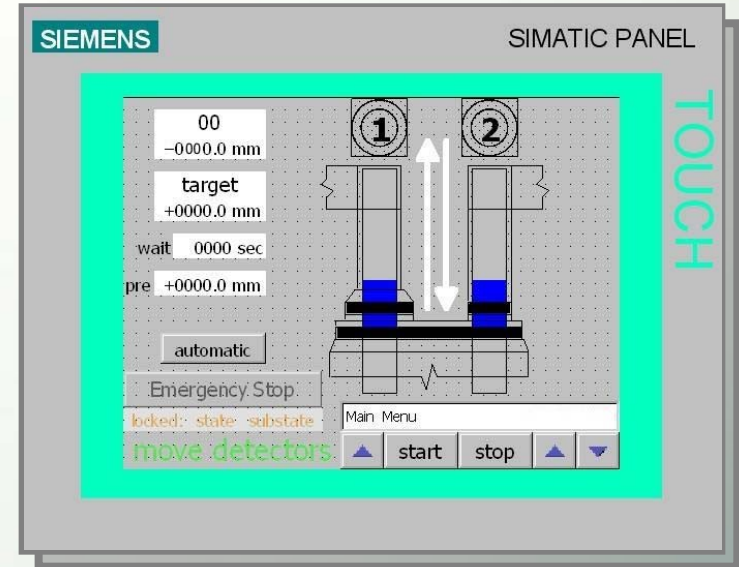
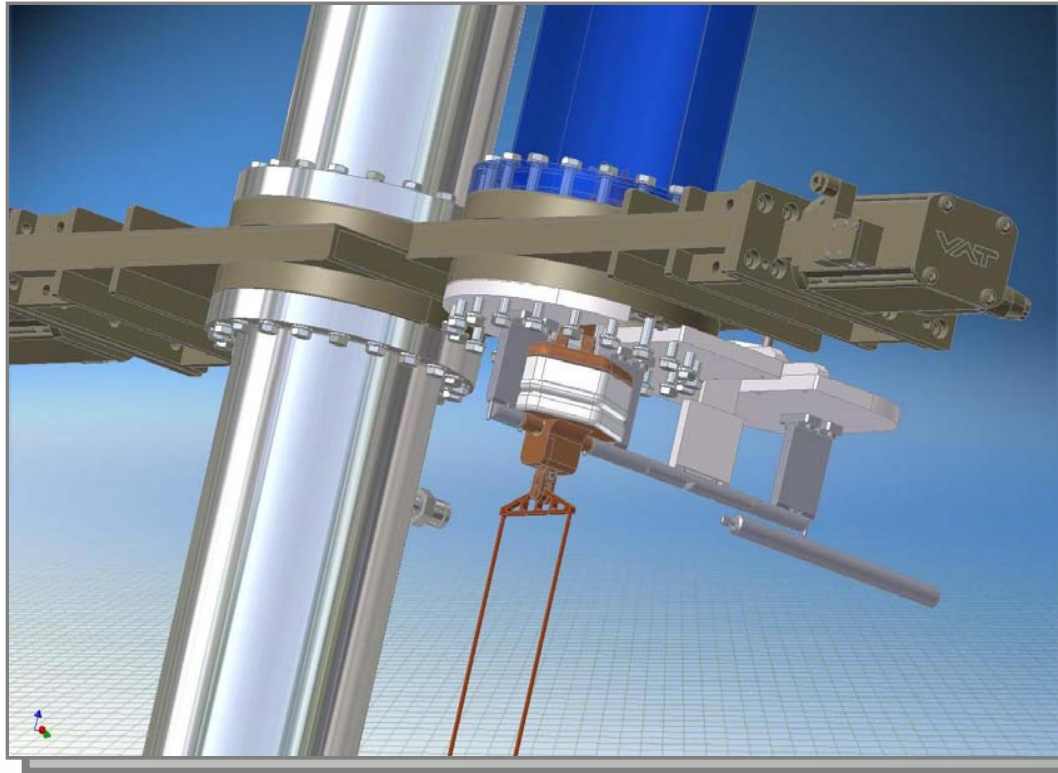

mount detector



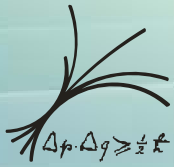

# Operator mode

Max-Planck-Institut für Physik  
(Werner-Heisenberg-Institut)

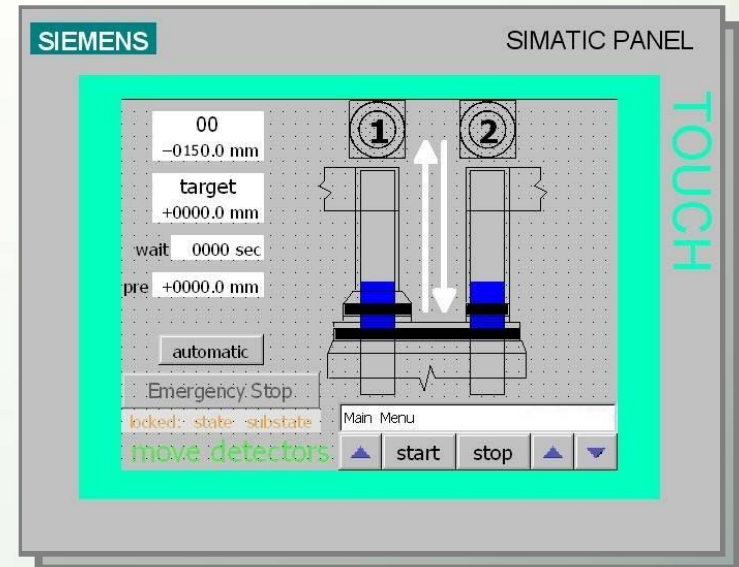
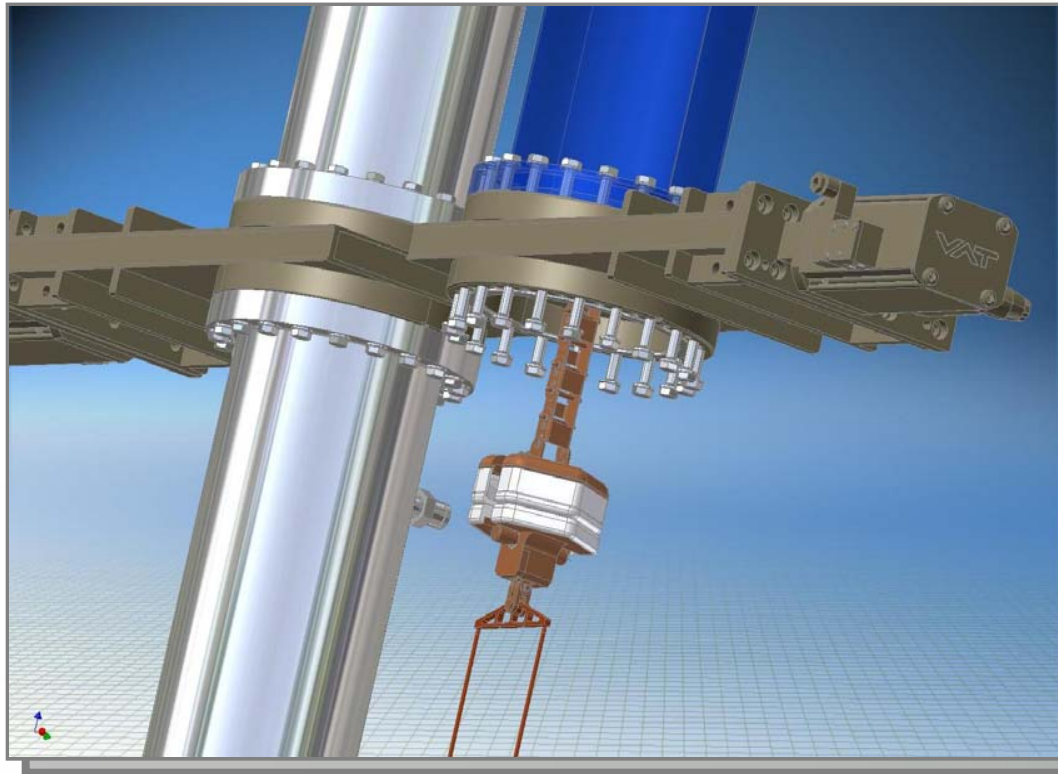

- +150 – GoTo - mtRailSys
- 130 – Auto – (un)mt String
- +20 – GoTo – unmt RailSys
- 150 – GoTo - parking position
- +900 – Auto - imerge string LAr
- 6000 – GoTo - parking position

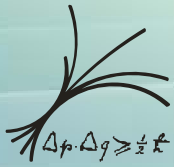

# Operator mode

Max-Planck-Institut für Physik  
(Werner-Heisenberg-Institut)

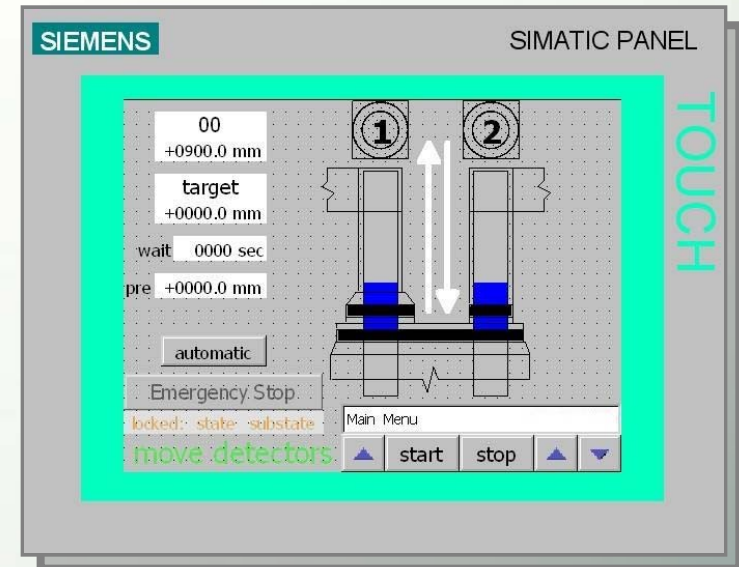
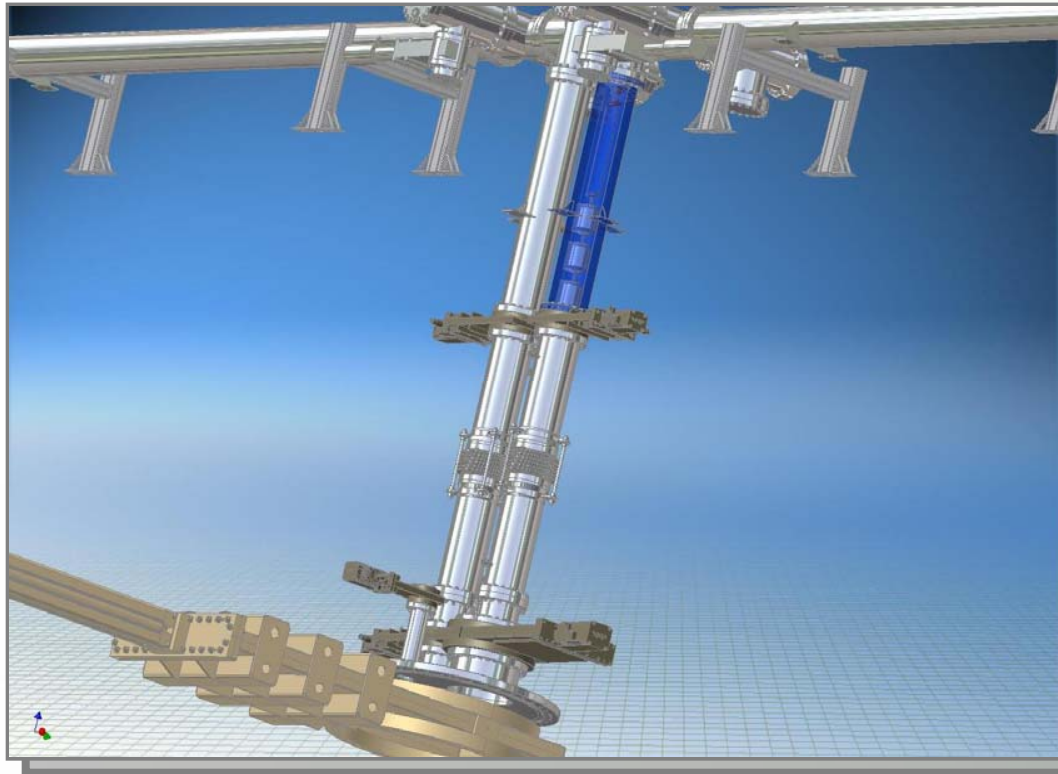

- +150 – GoTo - mtRailSys**
- 130 – Auto – (un)mt String**
- +20 – GoTo – unmt RailSys**
- -150 – GoTo - parking position**
- +900 – Auto - imerge string LAr**
- 6000 – GoTo - parking position**

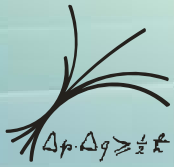

# Operator mode

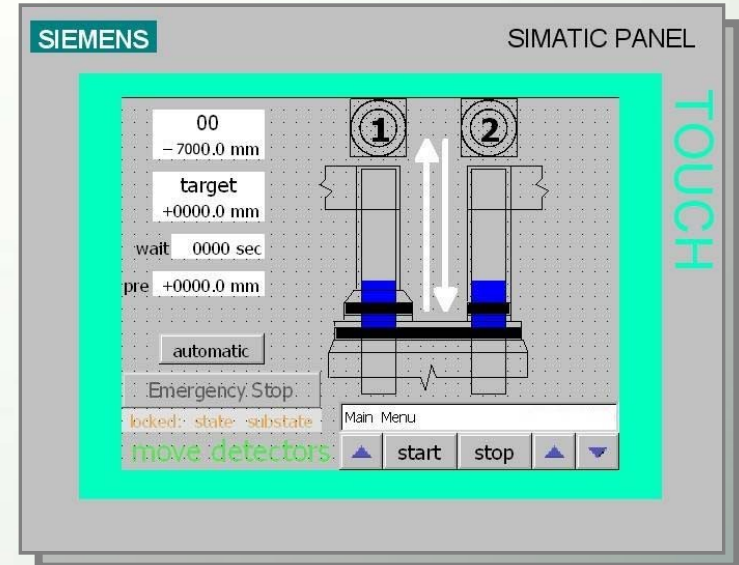
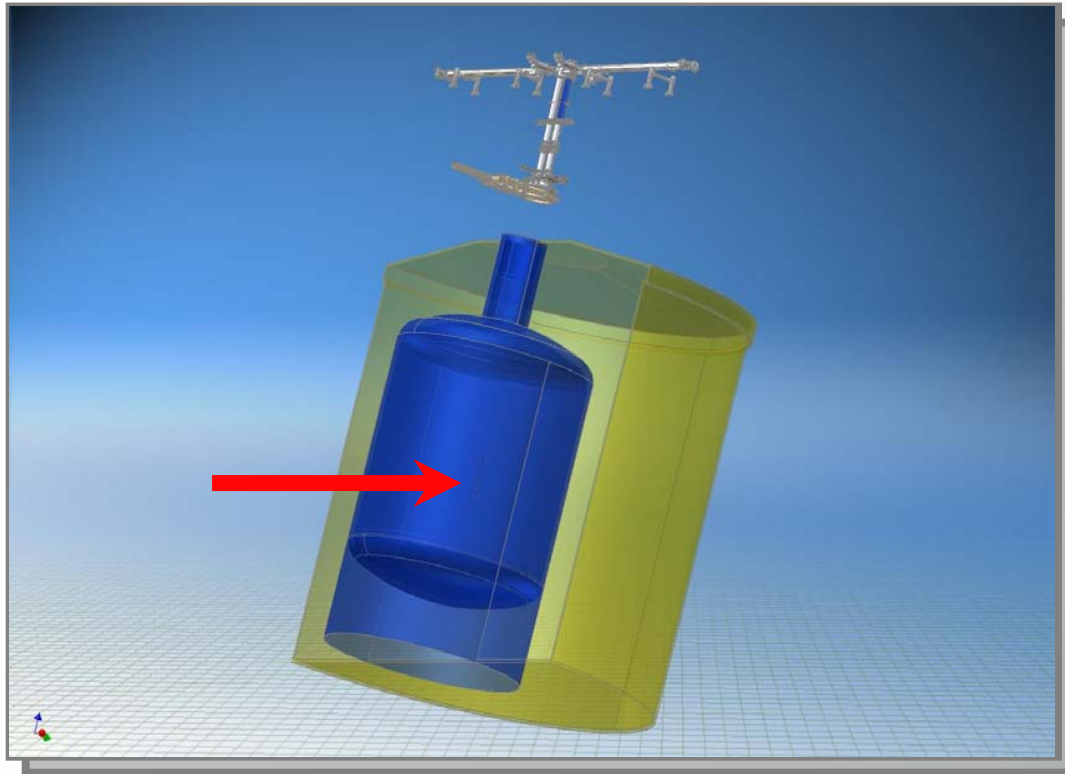

- +150 – GoTo - mtRailSys**
- 130 – Auto – (un)mt String**
- +20 – GoTo – unmt RailSys**
- 150 – GoTo - parking position**
- +900 – Auto - imerge string LAr**
- 6000 – GoTo - parking position**

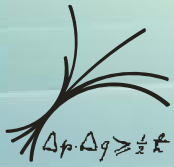

# Maintenance mode

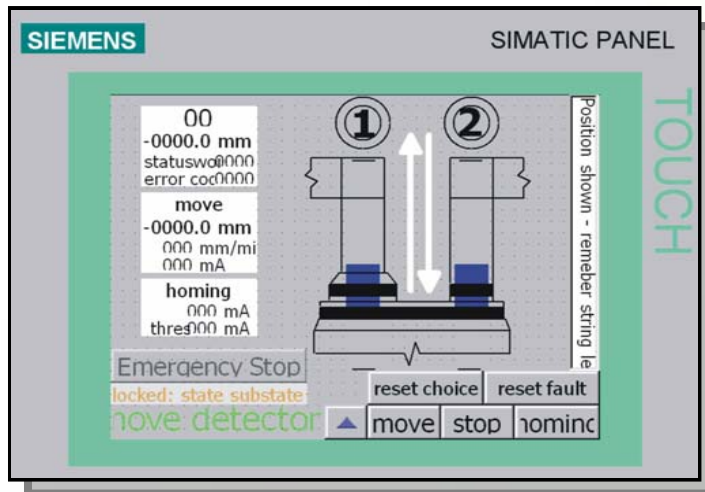

- cable arm selector
- indicator for up/down –ward movement
- rough illustration of the position
- live position
- desired position (absolut)
- velocity of the movement
- default current of the motor
  
- default current of the motor during homing
- threshold

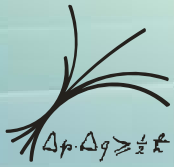

# Maintenance mode

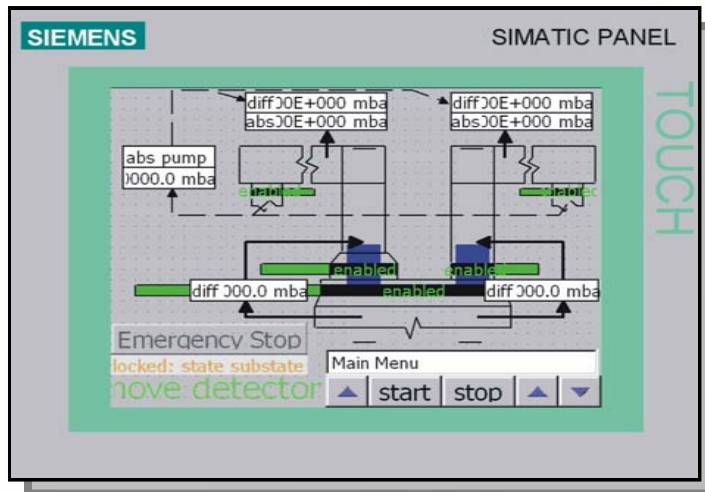

- absolut pressure in cable arm
- absolut pressure in the pump tube  
*calculated differential pressure at the pump shutter*
- differential pressure at the cryo shutter
- shutter menu
- status (enabled/disabled) of the shutter is indicated

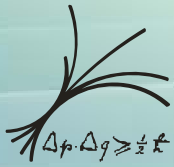

# *known problems*

## list of known issues

- three different logins (operator, maintenance, admin) caused difficult software
  - ↳ only one login for the final PLC (users)
  - ↳ software will be easier (only one hierarchy for interlocks)
  - ↳ number of screens on the touchpanel will be reduced (userfriendly)
  - ↳ collaboration has more flexibility with detector handling
  - ↳ motor programs and free movement of detector will be available
  - ↳ users need more knowledge
- „man-machine interface“ has to be improved
  - ✓ better graphical visualisation will help to „see“ where the detector (source) is

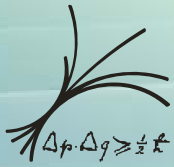

# *known problems*

- „man-machine interface“ has to be improved
  - ✓ graphical visualisation will help to „see“ where the detector/source is
  - ✓ event display will show which interlock blocks some actions and why
  - ✓ event display will show which error code has put the PLC to error mode
  - ✓ user friendlier units for detector movement
  - ✓ pressure has to be displayed while detector movement

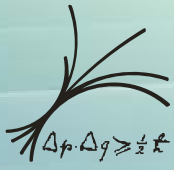

# security issues

- following error

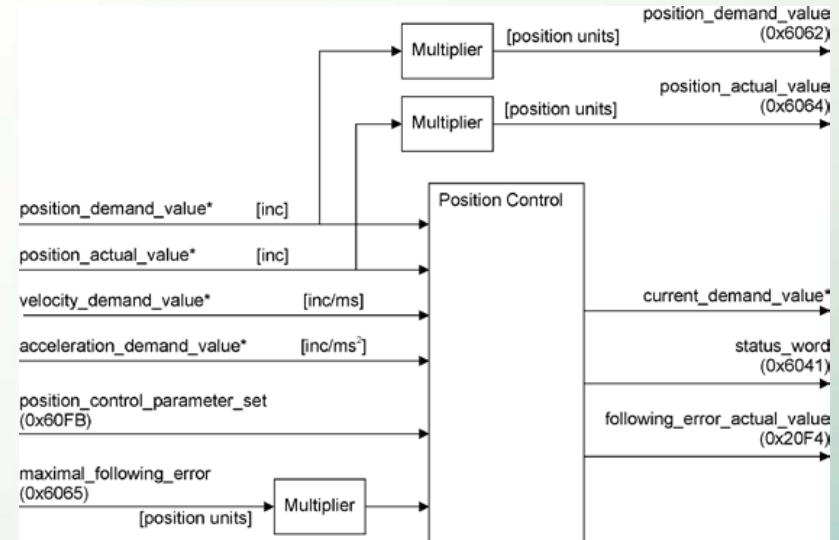
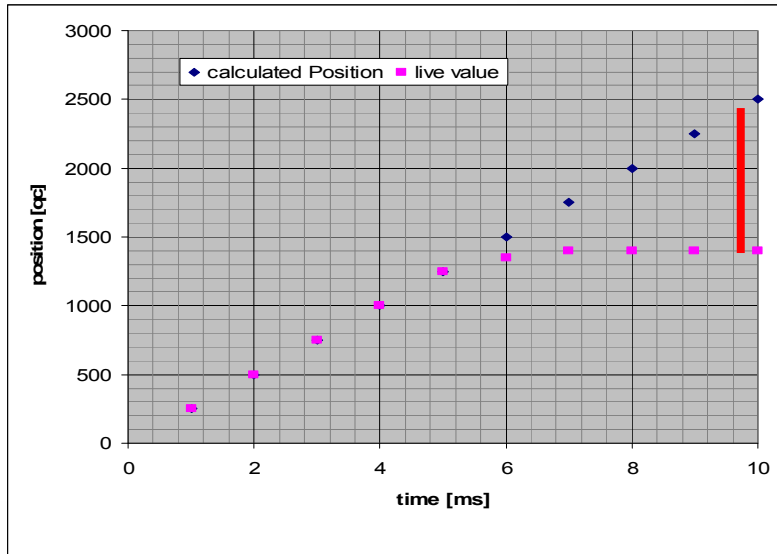

at the moment:

maximal\_following\_error (0x6065) = 125.000 qc  $\approx$  25 mm  
(hardcoded)



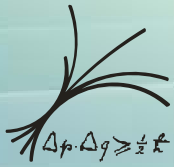

# security issues

- current limitation

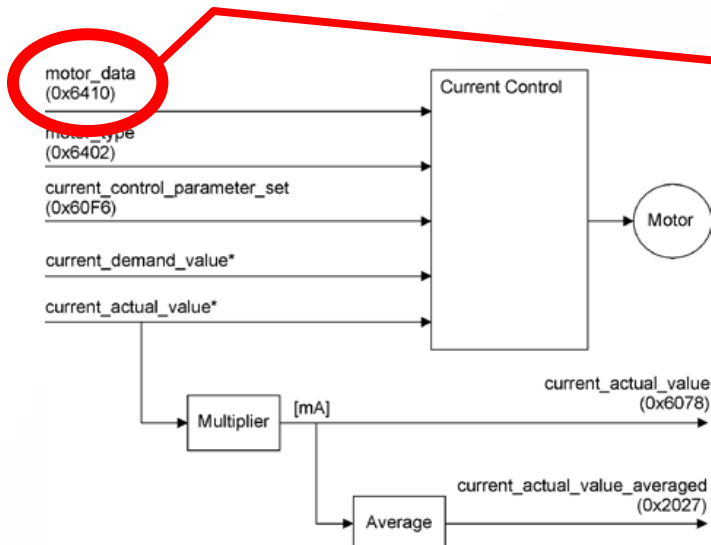

continuous current limit (0x6410 subind 0x01)  
output current limit (0x6410 subind 0x02)

at the moment:

continuous current limit= 450 mA  
output current limit =  $\frac{4}{3} \cdot 450 \text{ mA} = 600 \text{ mA}$   
(factor 4/3 is recommended)  
(hardcoded)

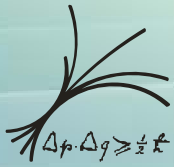

# *Final lock*

We will not use the final lock system that we have in Munich

- an enormous amount of value (Ge-76)
- we need professionals, who do the job
- we can not expect that Markus Kästle is around all the time and give support

Anapur is interested in the PLC for the final lock

There will be some meeting at the 26 october in Ludwigshafen

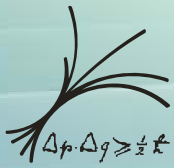

# Summary

The PLC for the temporary lock is installed and works fine

We have learned many things out of it and the new knowledge goes into the final lock system

The PLC for the final lock system will be programmed externally