



# **Cryogenic Vessel & Infrastructure**

## **Status Report for TG04**

K.T.Knöpfle  
MPI Kernphysik, Heidelberg  
ktkno@mpi-hd.mpg.de

GERDA Collaboration Meeting at LNGS  
4 - 7 November 2007

**cryostat**  
at time of Geel meeting  
delivery due by Oct 23

**copper shield**

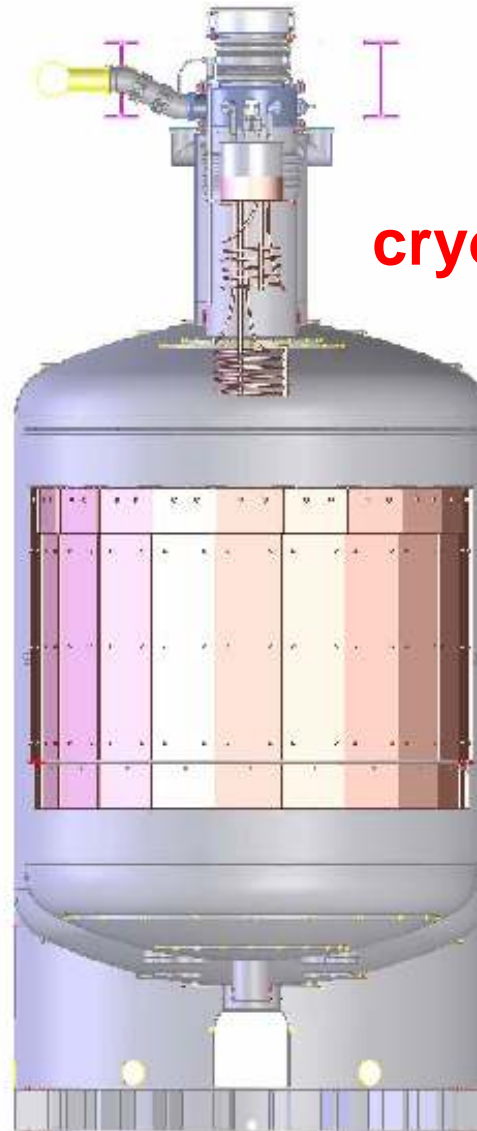

**cryogenic infrastructure**

**(schedule)**

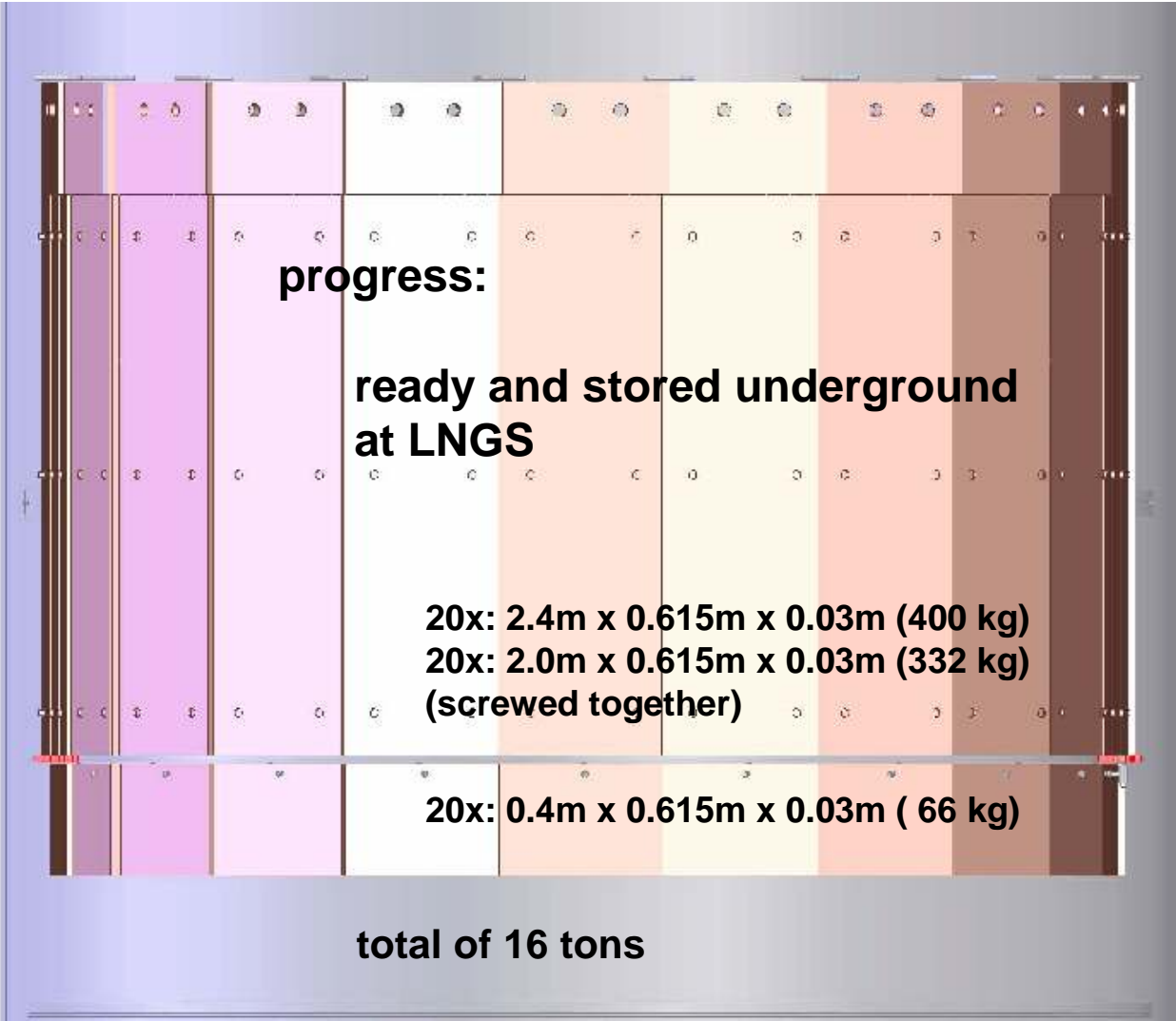



3 cm

OFRP copper produced by Norddeutsche Affinerie AG, Hamburg  
▶ delivered mid of March 2007

Copper rolled, cleaned\*, assembled and vacuum-packed by  
CSN Schreiber, Neunkirchen  
▶ shipped to LNGS by end of July 2007

\*cleaning procedure:

heated to 50 deg Celsius  
pickled in sulfuric acid (>15%)  
rinsed with de-ionized water



assembly



wrapping



vacuum-packaging



total of 10 boxes

boxing  
(2+2 segments)



(very slow) progress:

three vessel heads delivered in 03 Mar 07  
4th head needed repair  
delivery in 21 Jun 07 (6 months late!)

welding certification problems resolved  
by August 07

production gaining momentum since  
September 07 ► Photos of 22 Oct 07

continuous updates of schedules with  
increasing delay of delivery date:

Rev 3 of 02 Apr 07 : 23 Oct 07

Rev 4 of 10 Jul 07 : 08 Feb 07

now

Rev 5 of 21 Sep 07: 13 Feb 07

handed out and confirmed by SIMIC owner  
during visit at MPI HD on Sep 24, 2007



skirt

IV: top head

22oct07



22oct07





OV: top head

OV: bot head

neck

22oct07



skirt: top & bot fixation belts – tack welded



IV : supports for mounting tool

support ring for Cu shield



TIG welding

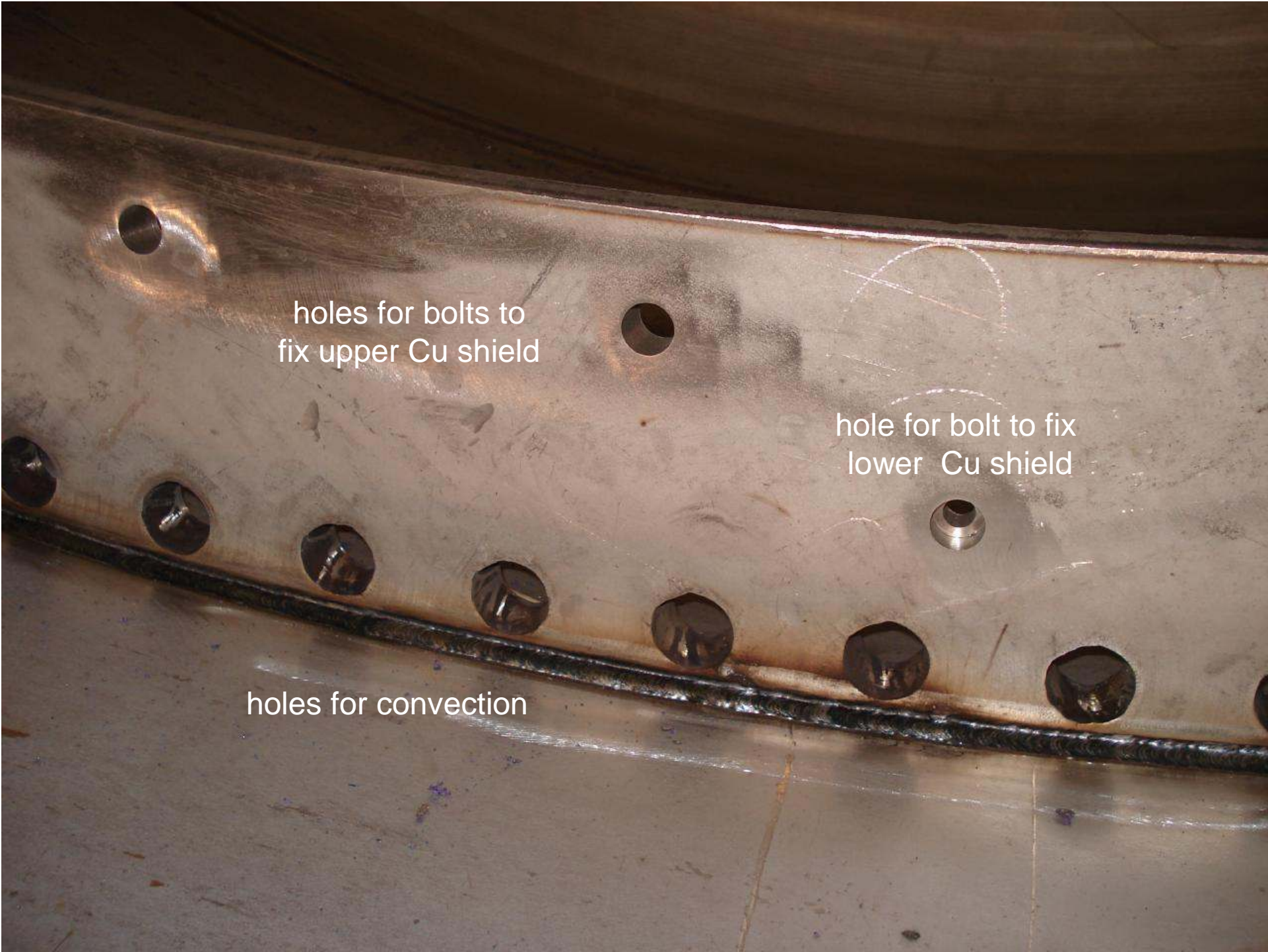

holes for bolts to  
fix upper Cu shield

hole for bolt to fix  
lower Cu shield

holes for convection



centering cylinder

8x support cage for Belleville spring & Torlon pad

IV – bot head

## TORLON pads



8x supporting inner vessel  
Ø 183 (100) x H 100



6x for centering inner vessel  
Ø 95/92 (44) x H 61/20



# pressure test of TORLON pads by TÜV

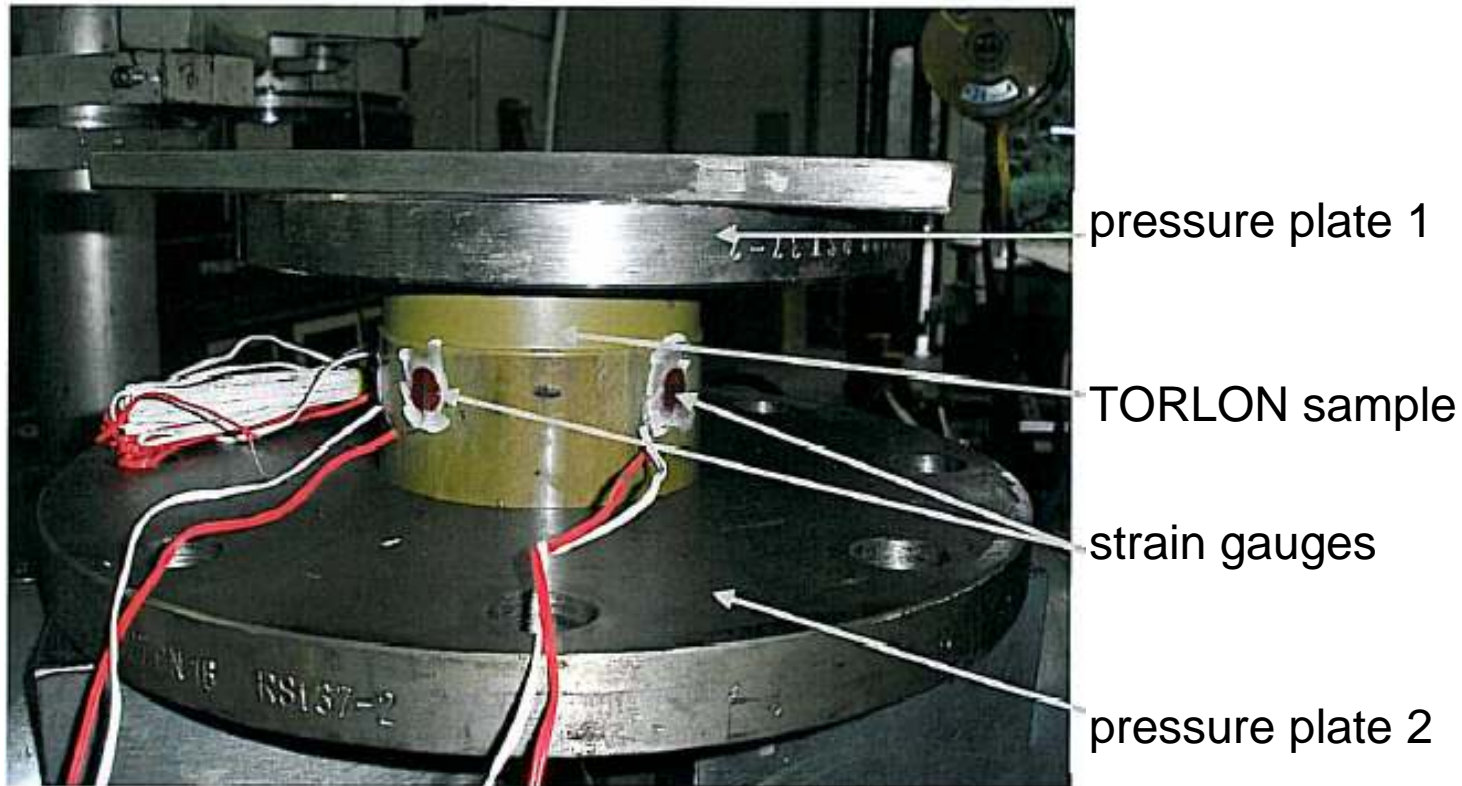

Successful test with load of 25 tons\* – for details see safety pages!

\* corresponding to 12 resp. 40 N/mm<sup>2</sup>





8x support for Torlon pad

OV – bot head



OV shell

automatic  
welding machine



still tack welded

IV - neck



groove for Helicoflex

tool for inert gas containment

IV - neck

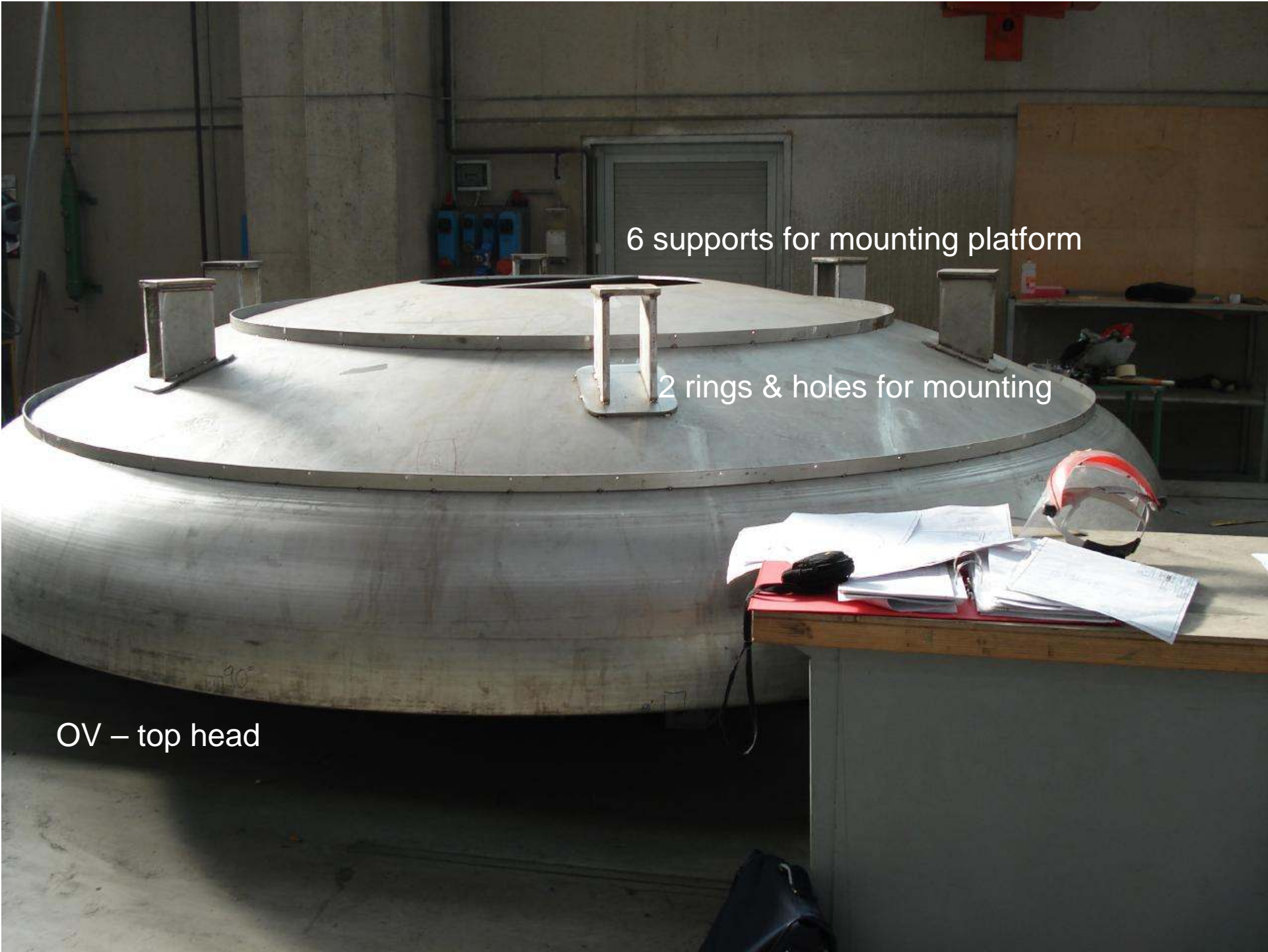

6 supports for mounting platform

2 rings & holes for mounting

OV – top head

# cryogenic infrastructure

prelim

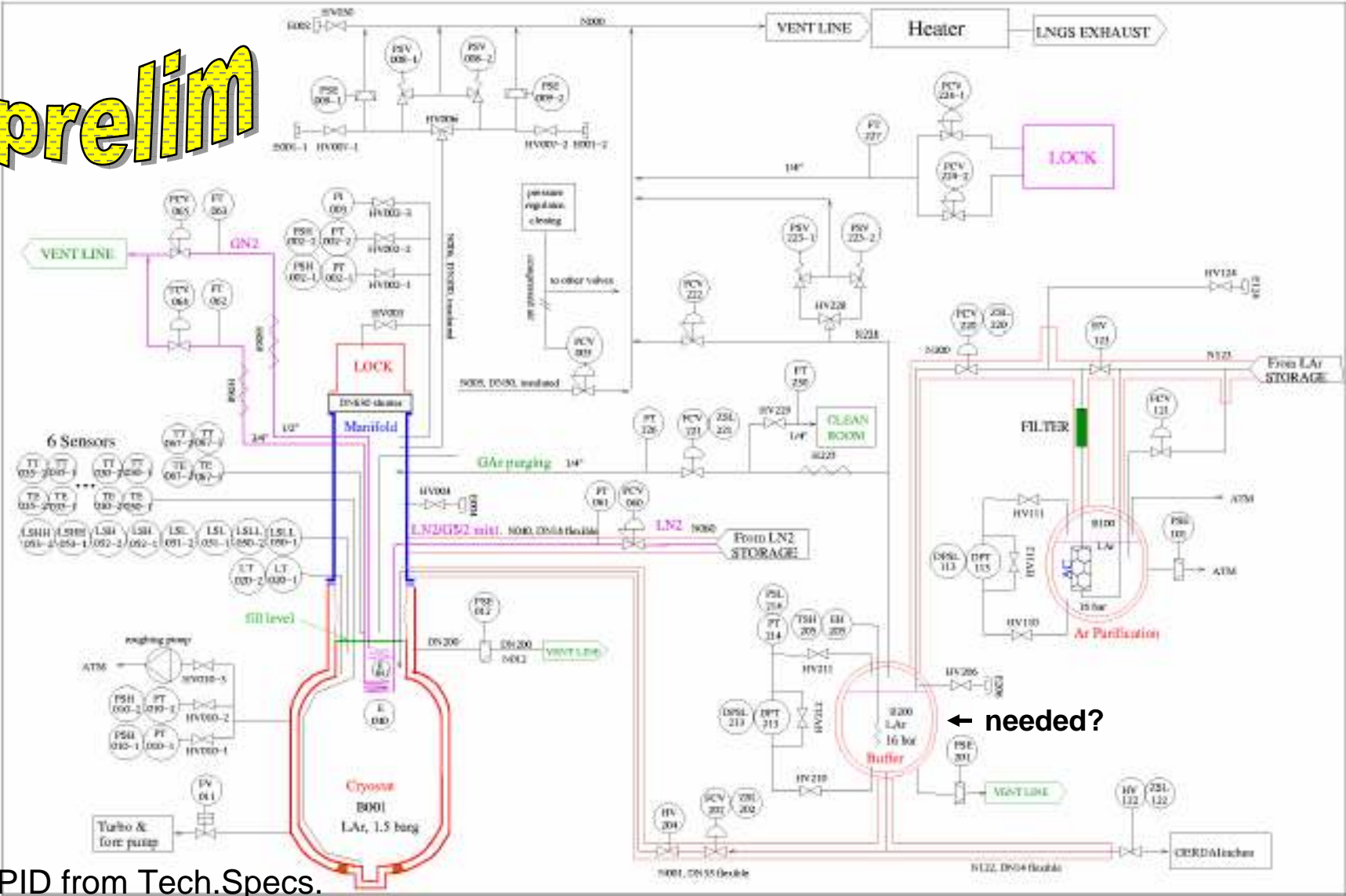

PID from Tech.Specs.

## progress:

**'Technical Specifications' for tender prepared & discussed with expert and two potential suppliers**

**Rn emanation/tightness of cryogenic valves measured, suitable candidates indentified**

**close to final design of manifold and neck instrumentation available ► figures**

## open issues:

**Rn emanation of safety valves (cast stainless steel) still to be shown to be acceptable**

**specs for heater of Ar exhaust gas (emergency case)**

# cryogenic infrastructure

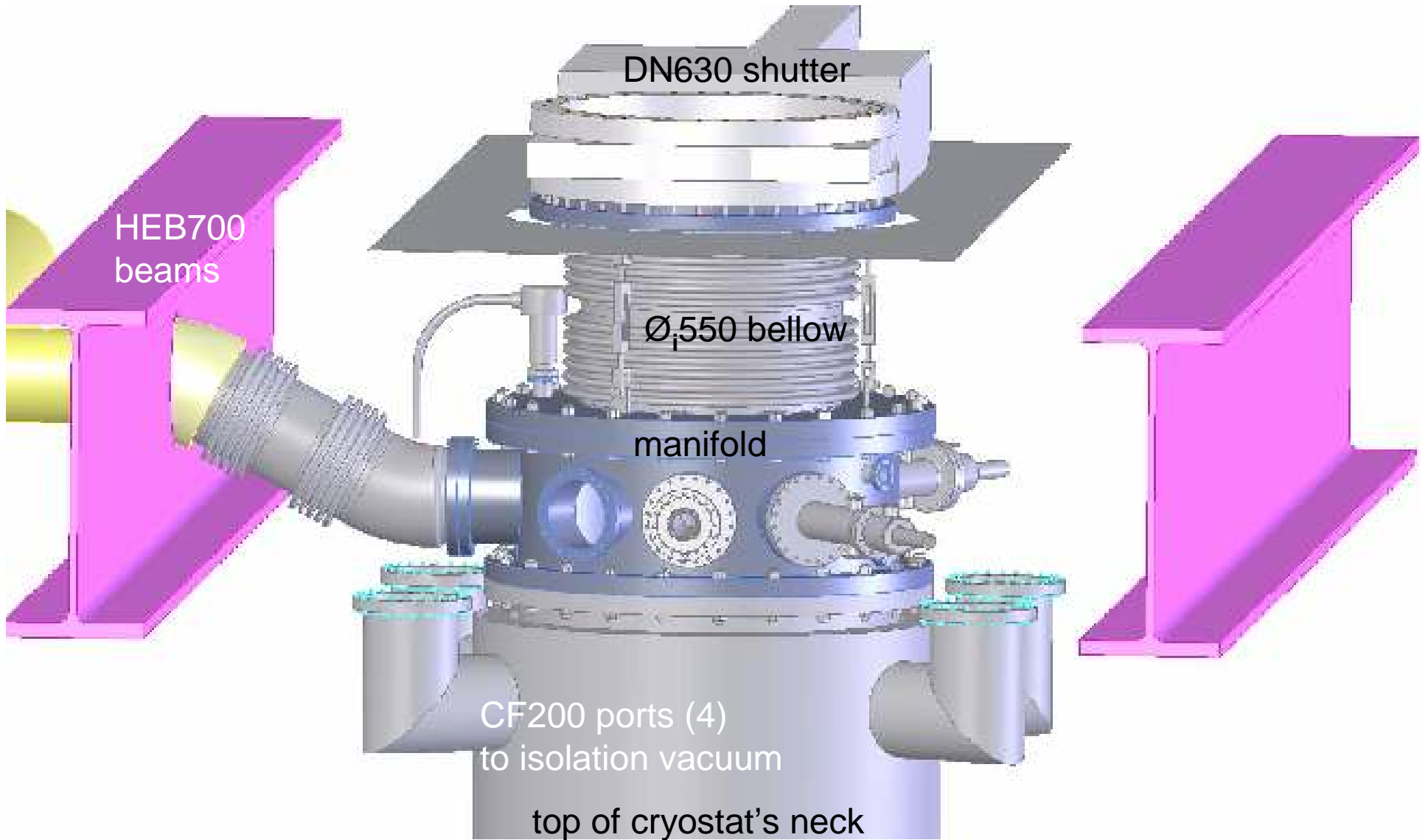



# cryogenic infrastructure

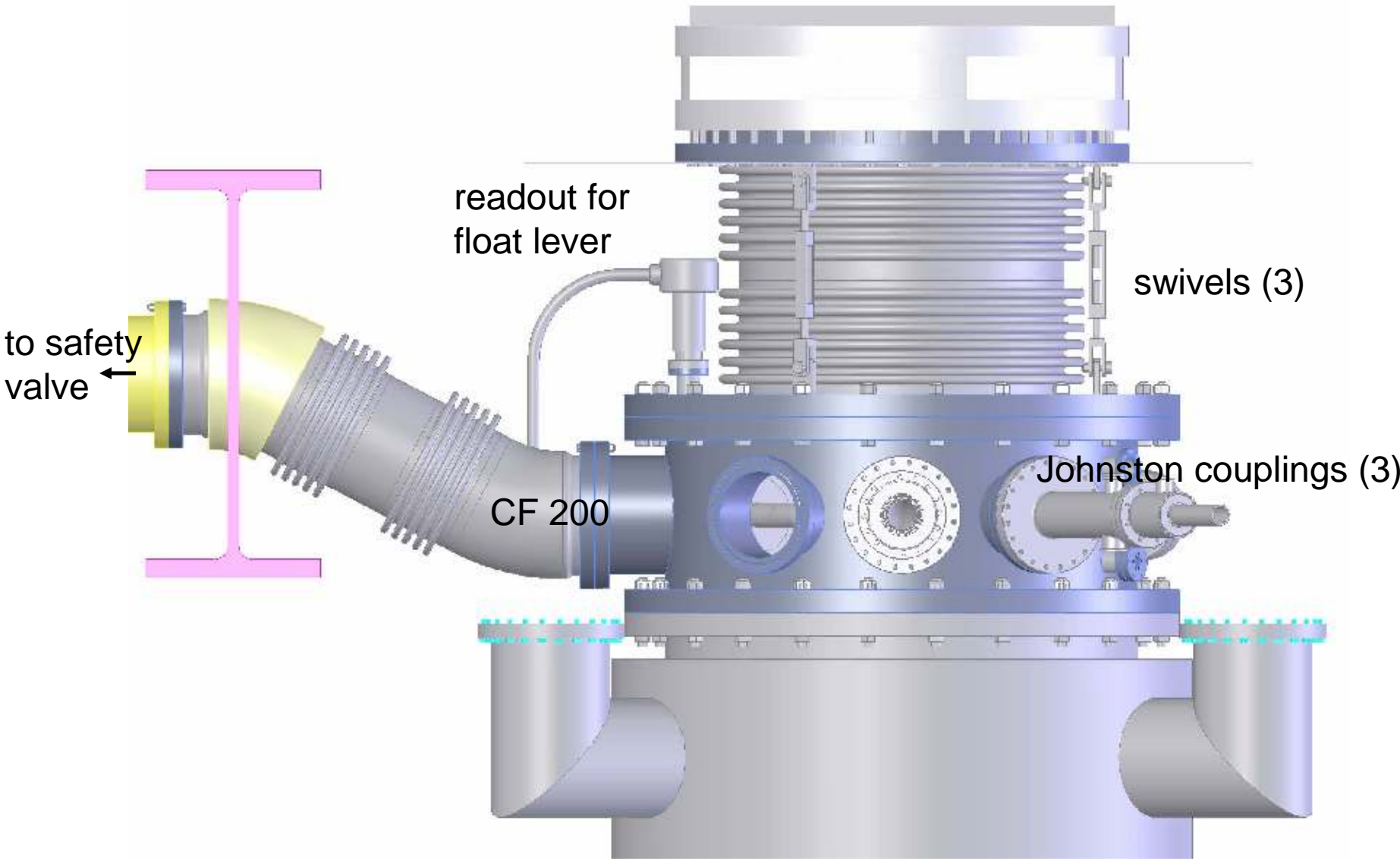

# cryogenic infrastructure

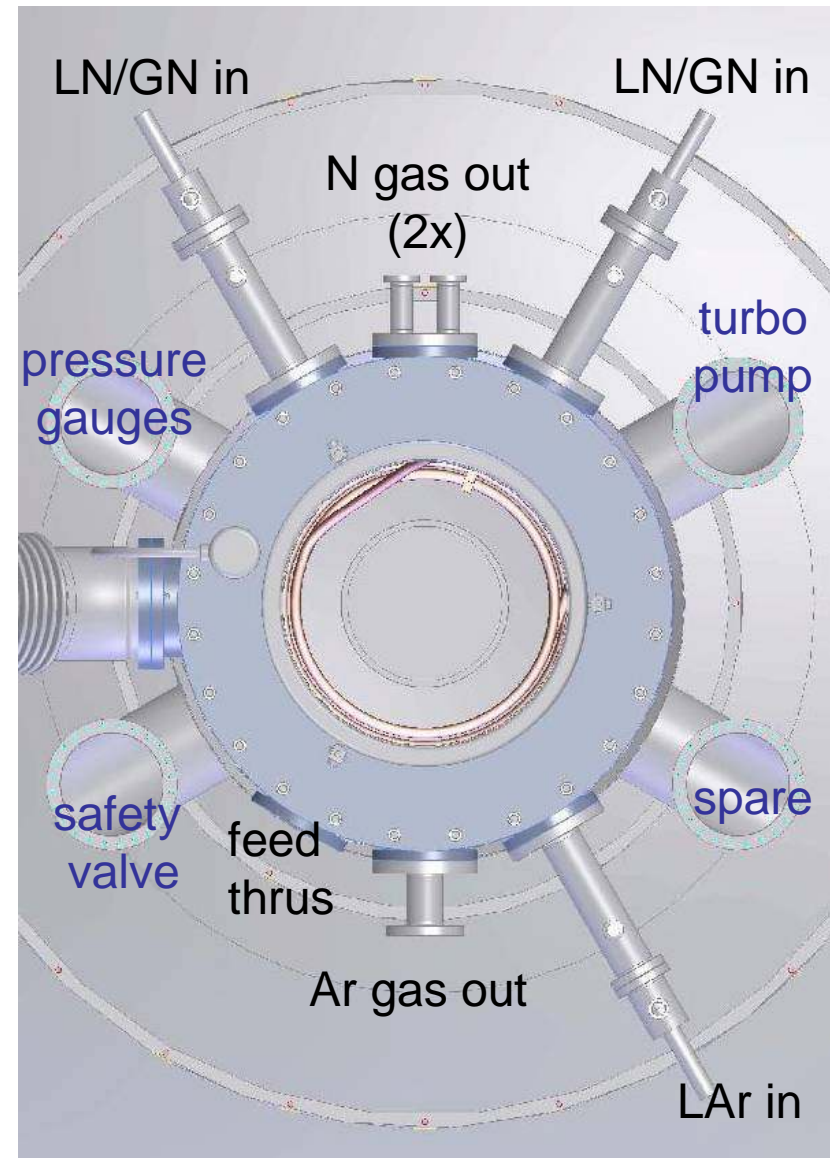
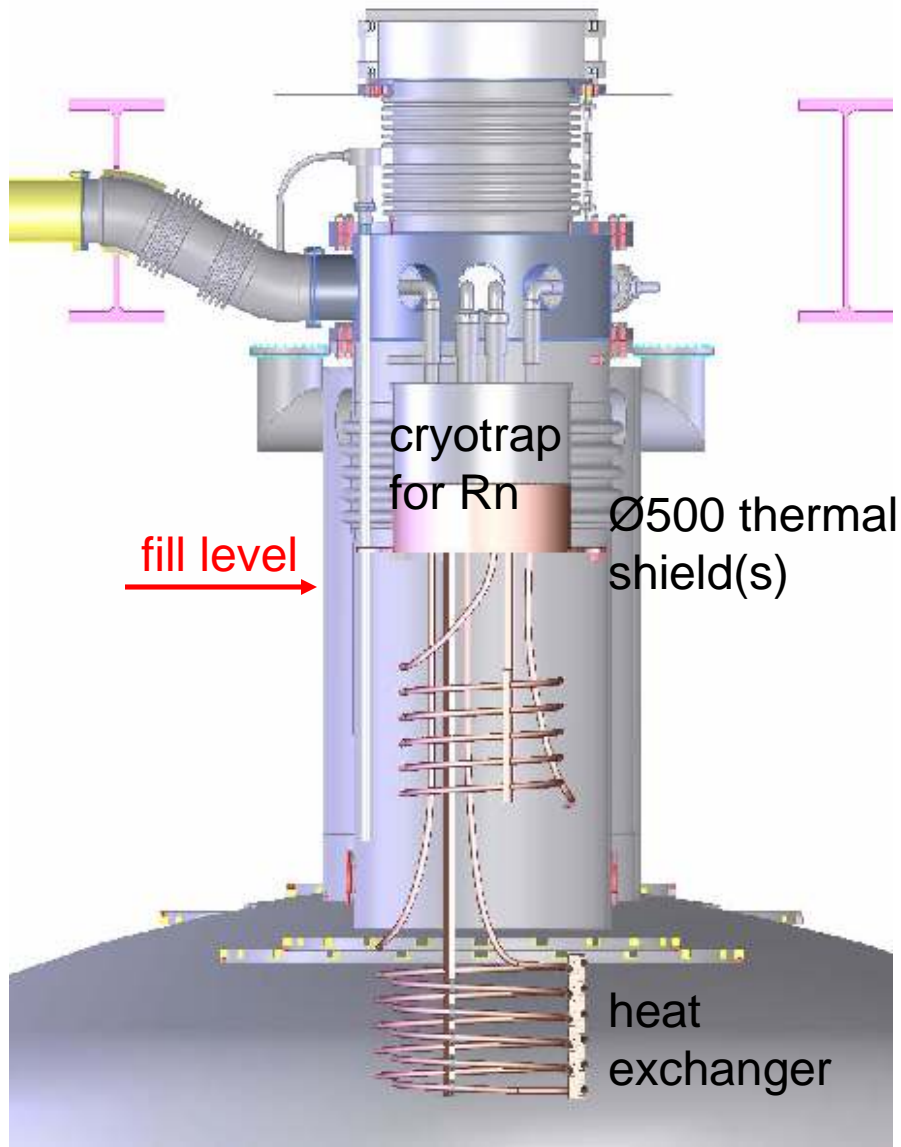

# schedule: rev 5 of Sep 21

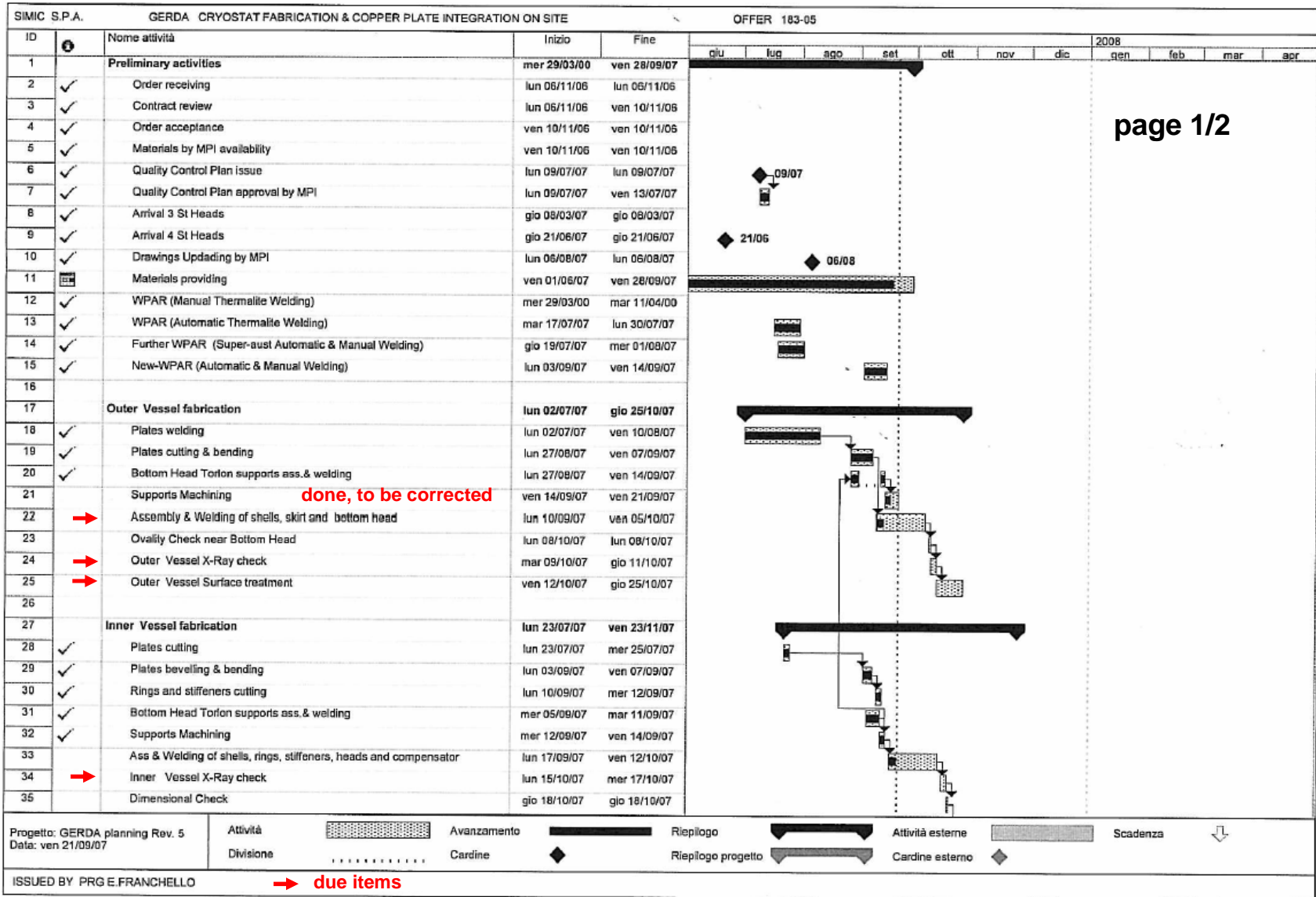

# schedule: rev 5 of Sep 21

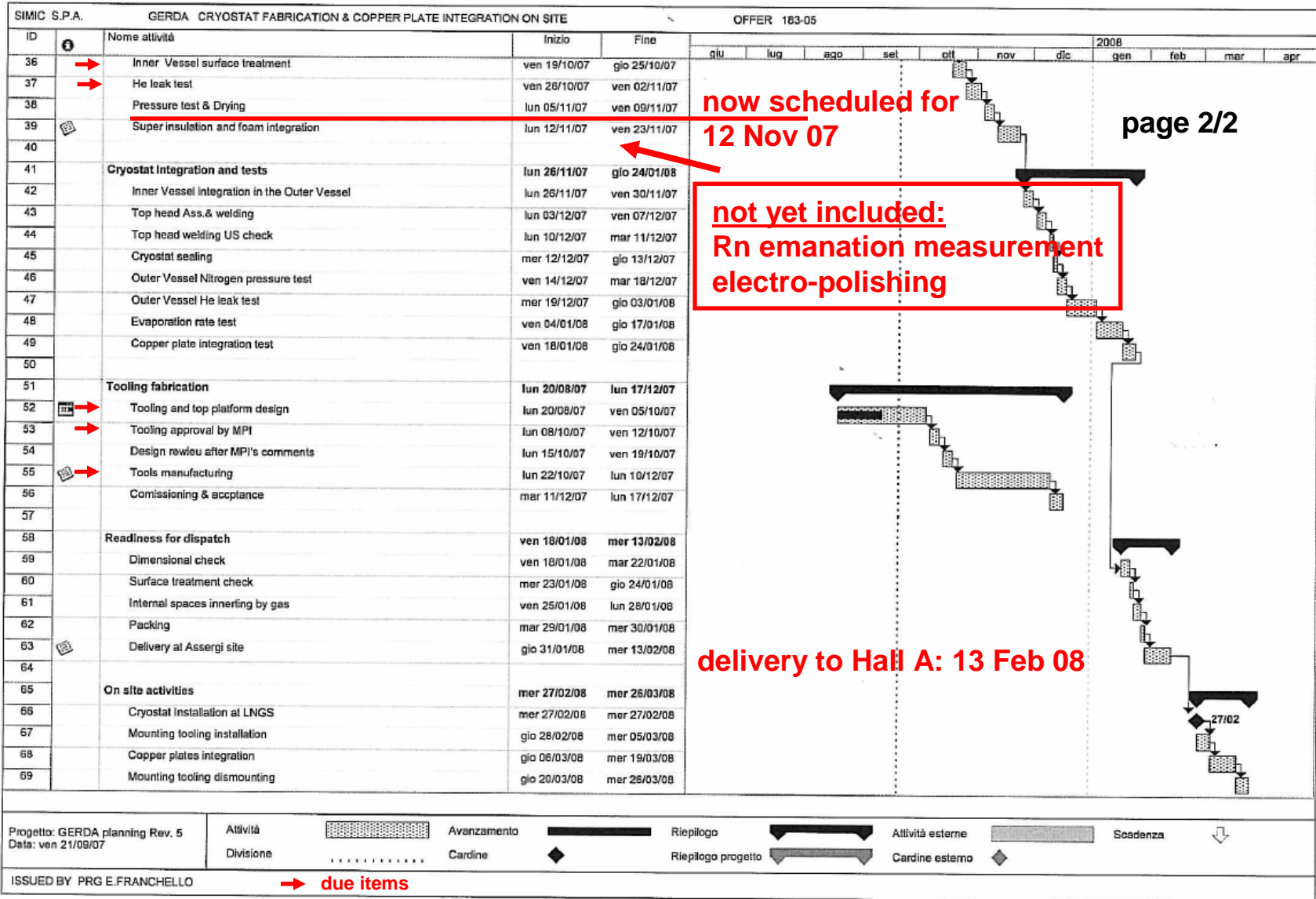

A photograph of a balcony view from a room. A green plastic chair is positioned on the balcony, facing the ocean. The balcony has a black metal railing. Pink curtains are tied back on either side of the balcony door. The ocean is visible in the background under a blue sky with light clouds. The text "waiting for cryostat ..." is overlaid in the center of the image.

waiting for cryostat ...

The End

---